

CHEMICAL HERITAGE FOUNDATION

JEAN H. FUTRELL

Transcript of an Interview
Conducted by

Michael A. Grayson

at

Futrell's home
Richland, Washington

on

28 and 29 October 2012

(With Subsequent Corrections and Additions)

ACKNOWLEDGMENT

This oral history is one in a series initiated by the Chemical Heritage Foundation on behalf of the American Society for Mass Spectrometry. The series documents the personal perspectives of individuals related to the advancement of mass spectrometric instrumentation, and records the human dimensions of the growth of mass spectrometry in academic, industrial, and governmental laboratories during the twentieth century.

This project is made possible through the generous support of the
American Society for Mass Spectrometry



This oral history is designated **Free Access**.

Please note: Users citing this interview for purposes of publication are obliged under the terms of the Chemical Heritage Foundation (CHF) Center for Oral History to credit CHF using the format below:

Jean Futrell, interview by Michael A. Grayson at Richland, Washington, 28 and 29 October 2012 (Philadelphia: Chemical Heritage Foundation, Oral History Transcript #0706).



Chemical Heritage Foundation
Center for Oral History
315 Chestnut Street
Philadelphia, Pennsylvania 19106



The Chemical Heritage Foundation (CHF) serves the community of the chemical and molecular sciences, and the wider public, by treasuring the past, educating the present, and inspiring the future. CHF maintains a world-class collection of materials that document the history and heritage of the chemical and molecular sciences, technologies, and industries; encourages research in CHF collections; and carries out a program of outreach and interpretation in order to advance an understanding of the role of the chemical and molecular sciences, technologies, and industries in shaping society.

CHEMICAL HERITAGE FOUNDATION
Oral History Program
FINAL RELEASE FORM

This document contains my understanding and agreement with the Chemical Heritage Foundation with respect to my participation in the audio- and/or video-recorded interview conducted by Michael A. Grayson on 28 and 29 October 2012. I have read the transcript supplied by the Chemical Heritage Foundation.

1. The recordings, transcripts, photographs, research materials, and memorabilia (collectively called the "Work") will be maintained by the Chemical Heritage Foundation and made available in accordance with general policies for research and other scholarly purposes.
2. I hereby grant, assign, and transfer to the Chemical Heritage Foundation all right, title, and interest in the Work, including the literary rights and the copyright, except that I shall retain the right to copy, use, and publish the Work in part or in full until my death.
3. The manuscript may be read and the recording(s) heard/viewed by scholars approved by the Chemical Heritage Foundation unless restrictions are placed on the transcript as listed below.

This constitutes my entire and complete understanding.

(Signature) Jean H. Futrell
Jean H. Futrell

(Date) March 26, 2014

OPTIONAL: I wish to place the following restrictions on the use of this interview:

Regardless of any restrictions that may be placed on the transcript of the interview, the Chemical Heritage Foundation retains the rights to all materials generated about my oral history interview, including the title page, abstract, table of contents, chronology, index, et cetera (collectively called the "Front Matter and Index"), all of which will be made available on the Chemical Heritage Foundation's website. Should the Chemical Heritage Foundation wish to post to the Internet the content of the oral history interview, that is, direct quotations, audio clips, video clips, or other material from the oral history recordings or the transcription of the recordings, the Chemical Heritage Foundation will be bound by the restrictions for use placed on the Work as detailed above. Should the Chemical Heritage Foundation wish to post to the Internet the entire oral history interview during my lifetime, I will have the opportunity to permit or deny this posting.

I understand that the Chemical Heritage Foundation will enforce my wishes until the time of my death, when any restrictions will be removed.

JEAN H. FUTRELL

1933 Born in Grant Parish, Louisiana on 20 October

Education

1955 BA, Louisiana Tech University, Chemical Engineering
1958 PhD, University of California, Berkeley, Physical Chemistry

Professional Experience

1958-1959 Exxon Research Center, Baytown, Texas
Research Scientist

1959-1961 Wright-Patterson Air Force Base, Ohio
First Lieutenant and Captain
1961-1966 Senior Scientist, Aerospace Research Laboratories

1966-1967 University of Utah
Associate Professor, Chemistry
1967-1986 Professor, Chemistry

1986-1990 University of Delaware
Professor, Chemistry and Biochemistry
1986-1997 Chair, Chemistry and Biochemistry
1990-1998 Willis F. Harrington Professor, Chemistry and Biochemistry
1993-1998 Professor, Chemical Engineering

1998-2002 Environmental Molecular Sciences Laboratory, Pacific Northwest
National Laboratory
Director
2002-2013 Battelle Fellow
2013-Present Battelle Fellow Emeritus

Honors

1995 American Chemical Society Delaware Section Research Award
2000 the International Symposium on Atomic and Surface Physics Erwin
Schrödinger Gold Medal

- 2004 First American honored by special issue of the European Journal of Mass Spectrometry and Honor Symposium in Konstanz, Germany
- 2006 PNNL Director's Award for Lifetime Achievement in Science and Technology
- 2007 Honor issue of *International Journal of Mass Spectrometry and Ion Physics*
- 2007 Frank H. Field and Joe L. Franklin Award for Outstanding Achievement in Mass Spectrometry by the American Chemical Society in Mass Spectrometry
- 2009 Elected to the Inaugural Class of American Chemical Society Fellows

ABSTRACT

Jean H. Futrell was born in rural Grant Parish, Louisiana, in 1933. An only child, he grew up in a household that included his parents and both grandfathers. He majored in chemical engineering at Louisiana Tech University where he was also enrolled in the Air Force Reserve Officers' Training Corps (ROTC). Summer jobs in Research Centers at Phillips Petroleum and the Humble Oil and Refining Company led him to consider attending graduate school to strengthen his credentials for a research career in industry.

Futrell selected the University of California at Berkeley, where his thesis research was in radiation chemistry in Nobel Laureate Glenn Seaborg's research group, with Amos Newton as his direct supervisor. His graduate studies introduced him to mass spectrometry as an analytical technique, but he was not allowed to do any experiments with the instrument. Nevertheless it played a vital role in Futrell's research, which featured a primitive form of gas chromatography to separate radiolysis products into mixtures whose components could actually be identified by mass spectrometry.

Futrell's first job after receiving his PhD was as a radiation chemist at Humble exploring applications of radiation processing of petroleum fractions. He also initiated research with ions using a mass spectrometer that had been retired from service. After eight months, the Air Force called on him to complete his military service obligation, and he traveled to Wright-Patterson Air Force Base in Dayton, Ohio. He was assigned to the Aerospace Research Laboratory, exploring gas-phase radiation chemistry and acquiring a mass spectrometer. He published more than twenty papers during his time there and remained at Wright-Patterson as a civilian scientist. Freedom and generous funding enabled him to develop tandem mass spectrometry as a precise way to explore ion-molecule reaction kinetics.

Futrell's decision to accept an appointment as Associate Professor of Chemistry at the University of Utah in 1966 was strongly influenced by Henry Eyring and Austin Warrhaftig's development of the fundamental theory underlying mass spectrometry and by the strength of their physical chemistry division. Futrell continued to build his own versions of spectrometers as unique research tools for exploring the frontiers of ion chemistry and for making significant occasional contributions to analytical chemistry, including increasing sensitivity of commercial mass spectrometers for addressing the detection of acutely toxic chemicals in the environment.

In 1987 Futrell accepted the position of Department Head of Chemistry and Biochemistry at the University of Delaware, a position he held for eleven years. An unexpected bonus was meeting Professor of Art Anne Krohn Graham; they were married in 1988.

In 1998 Futrell was recruited by the Pacific Northwest National Laboratory (PNNL) in Richland, Washington, to lead the William R. Wiley Environmental Molecular Sciences Laboratory (EMSL). This laboratory develops platforms for research in all areas of the molecular sciences. As the first Director of EMSL he set the priorities for staff recruitment and deployment of unique instrumentation that have attracted user scientists from every state and over twenty foreign countries. In 2013 he retired from active service and became the first Battelle Fellow Emeritus at PNNL.

Futrell discusses how he got interested in chemistry, the importance of communication and how working with young scientists becomes an effective means for educating yourself. Mentoring, competition, the importance of creativity, changes in mass spectrometry over the years, public perception of science, and information overload are briefly discussed.

INTERVIEWER

Michael A. Grayson retired from the Mass Spectrometry Research Resource at Washington University in St Louis in 2006. He received his B.S. degree in physics from St. Louis University in 1963 and his M.S. in physics from the University of Missouri at Rolla in 1965. He is the author of over forty-five papers in the scientific literature dealing with mass spectrometry. Before joining the Research Resource, he was a staff scientist at McDonnell Douglas Research Laboratory. While completing his undergraduate and graduate education, he worked at Monsanto Company in St. Louis, where he learned the art and science of mass spectrometry under O. P. Tanner. Grayson is a member of the American Society for Mass Spectrometry [ASMS], and currently is the Archivist for that Society. He has served many different positions within ASMS. He has served on the Board of Trustees of CHF and is currently a member of CHF's Heritage Council. He continues to pursue his interest in the history of mass spectrometry by recording oral histories, assisting in the collection of papers, researching the early history of the field, and preparing posters recounting historic developments in the field.

TABLE OF CONTENTS

Early Years	1
<p>Rural upbringing in Grant Parish, Louisiana. Loss of family land; father's work for railroad; free passes. Visiting relatives in California. Mobile library program. Both parents encouraged education. Liked chemistry; first practice teaching science while still in high school.</p>	
College Years	12
<p>Chemical Engineering at Louisiana Tech University. Air Force Reserve Officers' Training Corps at Louisiana Tech. Summer jobs at research centers of Phillips Petroleum in Oklahoma and Humble Oil and Refining Company in Texas; Joe Franklin. Toured schools; Impressed by Dean Kenneth Pitzer at University of California at Berkeley, his choice for graduate studies.</p>	
Graduate School	26
<p>National Science Fellowship (NSF) fellowship. Berkeley classes. Work in Glenn Seaborg's research group. Senior Scientist Amos Newton supervises his research in radiation chemistry. First experience with mass spectrometry. Discussions with physics Nobel Laureates Ernest Lawrence and Emilio Segre. Air Force service postponed; substituting visits to national laboratories and military research laboratories for required summer two-week tours of duty. Meeting Samuel Lind.</p>	
First Job	46
<p>Developing interest in mass spectrometry. First job at Humble Oil. Coffee breaks and lunchtime discussions with Fred Lampe and Frank Field; Occasional meetings with Joe Franklin. After-hours baseline experiments with discarded mass spectrometer. Meeting Peter Debye.</p>	
Wright-Patterson Air Force Base	61
<p>Military assignment at Wright-Patterson Air Force Base; research scientist at Aerospace Research Laboratory (ARL). Publications; international recognition. Appointment as civilian scientist, head of the physical chemistry division of ARL's Chemistry Laboratory. Life on base; adapting from military life to civilian. Installation of CEC 21-103. Funding. Double focusing mass spectrometer. Discussion of instrument manufacturers. Tandem mass spectrometer.</p>	
University of Utah	83
<p>Opportunity to work with Henry Eyring and Austin Warrhaftig. Three research grants. Summer at Berkeley as a Visiting Professor prior to joining the Utah faculty in September. Promotion to full Professor at the end of his first semester. New research directions, including the first interfacing of a mass spectrometer to a laboratory computer. Forays into applied science; joint appointments in the Colleges of Engineering and Medicine. First triple quadrupole spectrometer. Frequent travel to</p>	

Washington, DC; engagement in science policy. Election to leadership positions in professional societies, Sabbatical leaves at the Joint Institute of Laboratory Astrophysics, University of Paris, Fulbright Professorship at the University of Innsbruck and Exchange visits to Prague and Moscow.

University of Delaware 102

Accepts chairmanship of department. Two years to get lab equipped and set up. Pitzer's advice. Burnaby Munson and Douglas Ridge. Met and married Professor of Fine Art, Anne Graham. Elected Chair of the Council for Chemical Research; promoted Congressional visits by scientists and engineers. Invited by Battelle Memorial Institute and the Department of Energy to serve as Director of the William R. Wiley Environmental Molecular Sciences Laboratory (EMSL) in Richland, Washington.

Returning to the West 119

Accepts directorship of EMSL. Defining his mission. Many trips to Washington, DC. Finishes semester at Delaware. Safety standards and cost considerations at a national lab. Funding from U.S. Department of Energy (DOE) and Battelle Corporation. Futrell and Richard Smith become two of only six Battelle Fellows. Three years at EMSL; doubled funding, increased computer room by factor of five. Continued own research. EMSL's reorganization; becoming Chief Scientist for Fundamental and Computational Sciences Research Directorate.

Retirement 125

"Retired but not." Still involved in federal agencies and National Academy of Sciences committees. Collaborating and competing with Alan Marshall; 21-tesla FTICR instruments. Vicki Wysocki. Surface-induced dissociation (SID). R. Graham Cooks. John Fenn. William Hase. Considers mass spectroscope "ultimate chemical and physics lab".

Recap 137

Importance of mentoring, competition, and creativity in education and advancement of science. Changes in science and technology. Public perception of science. Overwhelming amounts of information with varying degrees of integrity now available.

Appendix: My Story 150

Index 172

INTERVIEWEE: Jean Futrell

INTERVIEWER: Michael A. Grayson

LOCATION: Futrell's Home
Richland, Washington

DATE: 28 October 2012

GRAYSON: I would like to begin this interview as I normally do, and that is by stating that I am at the home of Dr. Jean Futrell in Richland, Washington, at 2802 Appaloosa Way. This is 28 October 19—2012, and we're going to spend some time talking about Jean Futrell's career as a scientist and a mass spectroscopist. [laughter] Normally what we like to do is find out how these individuals became interested in science. This usually begins by, at least in my mind, trying to find out how his parents felt towards education, and perhaps maybe their parents, his grandparents, I guess, first off, where did you grow up? What part of the world did you grow up in?

FUTRELL: I grew up in rural Louisiana on a farm in Grant Parish, Louisiana. It was actually a railroad [junction] where they changed from one track to the other to switch cars in and out, and its name was Williana, [Louisiana].

GRAYSON: Williana?

FUTRELL: Williana. Yes. And my family, I've learned only fairly recently because of my daughter's interest, that they owned a substantial part of Grant Parish, Louisiana. By "they" I mean my ancestors did.

GRAYSON: Is that Grand or Grant?

FUTRELL: Grant. Named for Ulysses S. Grant. And named by the Carpetbaggers' Legislature after the Civil War. [laughter] It never occurred to me that the family was all that large. I just did the arithmetic this morning. By virtue of the fact that I had on the average twenty kids in my class from elementary school through high school, and I typically had one to two first cousins or second cousins. So, we must have amounted to something between 5 and 10 percent of the population. [laughter]

My memory is growing up poor. My father dropped out of school in the sixth grade because boys were useful on the farms in those days. My mother had fairly advanced education compared to her contemporaries, and then she went to the tenth grade in San Francisco [California], where she lived, where she grew up. And my parents met each other at the end of World War I. My father was in the [U.S.] Navy the last year of World War I, and he stayed on the West Coast in the [U.S.] Merchant Marines, and that's where my parents met each other in San Francisco. As I said, I grew up in Louisiana in a poor family, but if I do, again, do the math and recognize that my grandfather, my father's father, who lived with us when I was growing up, until he died when I was about twelve years old, actually had twelve children, and he gave each one of them a farm, and if they—if they chose, I mean, as a wedding dowry kind of thing, gave each of them a farm of 60 to 80 acres of land, and if they were interested, he would also set them up with a country store and a service station. If I calculate what it would take to do that then my grandfather was wealthier than almost anyone else I've known at one point in time.

However, things changed. The Great Depression, which is kind of the time when my parents were married, I guess in 1929, 1930, I've forgotten which. My birthdate is 1933, and I was born in Louisiana, and it's partly because my father's <T: 5 min> father, my grandfather, came to visit them when they were married. He brought my mother back to Louisiana for three months, and they made the collective decision to move from San Francisco. It's something I always found difficult to understand after I got to see San Francisco. But anyhow, that's what happened. And then the [Great] Depression occurred. There were various things that took place. The Civilian Conservation Corps [CCC] took land away from my father, and World War II, they took more land away, so it ended up as a totally non-productive farm. Enough people were pushed out, forced to move, to make room for federal facilities, that there was no longer a viable clientele.

GRAYSON: I don't understand exactly what's going on with the Civilian Conservation Corps. Why were they taking people's property in that part the country at that time?

FUTRELL: Oh, [the Federal government created the Civilian Conservation Corps to employ people and work on infrastructure issues in national parks, national forest preserves and the like. They established] a major camp [regional CCC, with barracks, medical facility, and local headquarters in our rural community. It] had something like [twenty-five] buildings built in what had been my father's property at one time. He had [a few years of] temporary prosperity when they were there, because he was the barber for the [CCC camp], and he was a blacksmith, and helped them do various things. There was a period where that was very helpful to keep [my parents going in the second term of Franklin [D.] Roosevelt's presidency].

GRAYSON: So, this was part of Roosevelt's administration's...

FUTRELL: Yes, that's right.

GRAYSON: ...attempt to get the country out from under the Depression?

FUTRELL: Exactly. That's part of FDR's recovery program.

GRAYSON: But it kind of ended up stepping on your dad.

FUTRELL: [laughter] Yes. It stepped on some people, but it also kept them going in other ways. So, what they did is they built roads and bridges, all kinds of things, improvements. They developed a national forest [Kisatchie National Forest] nearby, created campgrounds, lakes, all kinds of things, recreational facilities. Infrastructure, in other words. They also helped in the construction of the first paved highways going through that part of the state.

GRAYSON: As a result of this activity, your family was a lot worse off in the long run financially than before?

FUTRELL: Yes. I actually discovered in my father's belongings that he actually had extended credit to [a number of families for groceries at our country store for several years]. During the Depression, a lot of his assets turned out to be debts. So he kept things going until they sort of all went down together in the Depression. My other grandfather, my mother's father, probably because of the effect of the Depression in California, he ended up moving back to live with us, and so my mother had her husband, her husband's father, her father, and me. I was an only child, not because they planned it that way, but because of Rh factor problems. [My blood type was A positive and carrying me successfully to term sensitized her immune system to successive children.] So, I was the firstborn, and there were two other children that she carried to term that lived a few hours or a few days, and several others that were spontaneously aborted. Of course, they didn't know what the cause of it was, and I actually learned as a graduate student about the Rh factor problem and how lucky I was to be the firstborn, [...] only survivor...because Melvin Calvin, Nobel laureate [Chemistry, 1961] at [University of California] Berkeley, had the same problem with his family, but he and his wife were scientists, and so they [did the research to understand] what the problem was, and of course, now it's something that's managed by the medical profession, but certainly was not the case in the 1930s.

GRAYSON: And in rural Louisiana.

FUTRELL: And rural Louisiana, of all places.

GRAYSON: So, I want to get a little bit into the educational aspect of whether your parents and grandparents prompted you in becoming...in your schooling, or encouraged you in it, or was there any attitude whatsoever towards school, or—

FUTRELL: Well, my <T: 10 min> parents were encouraging, my mother particularly, because she talked differently and dressed differently from the other women in the deep South, and she differed in having an interest in reading. The other phenomenon in Louisiana in those days is that Huey [P.] Long [Jr.] was governor of Louisiana, and later his brother Earl Long was governor. Huey Long had a slogan of “a chicken in every pot,” and by modern political standards, he’d be considered a socialist, I’m quite sure. [laughter] But there were some benefits, okay, in rural Louisiana, in that he had created...Huey Long had created a rural library system called bookmobiles. And so once per week, wherever you were, anywhere in the state, this little RV-sized library would come by, and so you could check out books. And I’m quite sure my mother and I were the best customers in that part of Grant Parish. They also had a health-care system, so once per year there was a clinic on wheels that would come by and give people...make sure they had a chance—I’m not sure they were given an option, I think they just inoculated everybody against whatever diseases—

GRAYSON: True socialism. Wow.

FUTRELL: [Yes], true socialism. [laughter] And there was dental thing that came by every two years to look at your teeth. So, there were certain things, you know, that were special.

GRAYSON: So you were poor, rural Louisiana, but you had a lot of advantages or privileges, so to speak, that a lot of people didn’t have.

FUTRELL: Exactly. We had some advantages. So, reading...reading was probably the most important single factor in my life and as we were discussing last evening, the ability to write—to express yourself in writing. And I think that comes immediately from reading a lot, to understand how other people have expressed themselves. Anyhow, my parents encouraged me. They got me into school, Dry Prong Elementary School.

GRAYSON: I’m sorry. How do you spell that?

FUTRELL: Dry Prong. Almost in the center of the state of Louisiana. Interesting little town. Again, I think it was semi-socialist. They had consolidated schools, and so Dry Prong schools,

elementary, junior high, high school, all in the same campus, gathered people from about a 15-mile radius by school buses. We had a very dispersed population. And I was always up early in the morning to catch the school bus. We had an hour's ride.

GRAYSON: Oh, wow.

FUTRELL: Picking up other kids before we get to school, and an hour's ride coming home. But that was normal. That's what it was. My mother, I'm sure, continued to encourage my reading. I exhausted the grammar school library by about the third grade, and I got a special pass to cross the road to the high school. [laughter] And I wiped out the high school library. [laughter] And then they had to start buying books for me. Now this was my mother. My father read one book. He felt that was enough. It was the King James Version of the Holy Bible. We had many discussions about this as I grew up. [laughter]

GRAYSON: There's only one book that counts.

FUTRELL: Exactly.

GRAYSON: You said that your mother got you into this school. Would you have normally gone...you wouldn't have normally gone to this school? You would have gone to maybe a - a closer...

FUTRELL: No, no. No, there was no closer school.

GRAYSON: Oh, okay.

FUTRELL: They had closed those down. There were one-room schoolhouses, but they had been closed, and this was related to Huey Long and his attempt to bring rural Louisiana—where he was born, actually, not too far from where I was born, I don't know whether there's any trace elements in the soil or not—but the one-room schoolhouses were closed. Not <T: 15 min> everyone agreed this was a good idea, but they had consolidated the school system, and buses to get everyone to school.

GRAYSON: So, you could say that Huey Long had a fairly large impact on your educational experience.

FUTRELL: Well, indirectly, yes. [laughter] Ronald [W.] Reagan later on, but... [laughter]

GRAYSON: So you're saying then that your mother was...you said started buying books for you, then.

FUTRELL: Yes, that's right. They were, you know, not sophisticated books, until I could earn some money on my own. And the other element in my life that was unusual, and I think differentiated me, let's say, from my cousins, is that my mother was from San Francisco. When I was born, her mother, that is, my grandmother, and her grandmother, my great-grandmother, came down to assist in my birth. Of course, I was unaware that they were there. But my great-grandmother became sick in 1939. I was six years old, or nearly six, I should say, when I made my first trip to California with my mother. And I met my grandmother, to get to know her for the first time, and my great-grandmother was sick, so I saw her. We stayed there for approximately a month, until she died, and I was there for the funeral.

But I got to know my mother's mother, my grandmother, and again, because of the poverty in the South, the fact that the farm was non-productive, the country store didn't have enough customers and huge debts, my father started to work for the railroad. And that would have been 1941, I think, when he started to work for the railroad. And after you worked for them for a year, you got a pass for your family. Now of course Pearl Harbor happened, and so the world changed, and all of a sudden we had soldiers, lots of soldiers, in our neighborhood, and they helped a little bit with the store, because they would sneak across the border to buy a Coke and things like that.

GRAYSON: Border being the...

FUTRELL: The boundary of...

GRAYSON: ...military camp?

FUTRELL: [Yes], Camp Livingston Firing Range. And of course, kids like me and my friends, a couple of cousins, would sometimes cross the other side. And I was fascinated to see that they had constructed a Japanese village. They were doing maneuvers and planning eventually to invade Japan to get even, so to speak, and so military observation being part of the life—was part of it. And I did the free trips to California, but they were troops trains, and so my mother and I would get bumped off in strange places throughout the country. So I got to know a little bit more of the geography of the United States than typical of kids in rural Louisiana.

GRAYSON: Interesting. Meeting your grandmother also had a bit of influence as well.

FUTRELL: Sure, it did. And she lived in San Francisco in a two-story house, and she took me to my very first seafood that wasn't involved in starting with worms and heading for a local creek. [laughter] And so, interesting seafood. I mean, I got clam chowder and encountered that for the first time in my life. And Chinese food. Boy, was that fancy stuff. So as a young kid, I, you know, developed a taste that I still have for exotic foods, I guess.

GRAYSON: Kind of a cosmopolitan upbringing for a Louisiana rural...

FUTRELL: Exactly. Exactly. And instead of the hot and humid South, about a month in San Francisco. It made a difference. I'm quite sure it did. One of the other things that my teachers told me—because as I mentioned, there were lots of Futrells in the neighborhood, I don't remember which one, but something like third grade—some one <T: 20 min> of my teachers said, "All the Futrells are smart. That's not special. What's different about you is you're focused." And I think that's...

GRAYSON: This is the third grade?

FUTRELL: Third grade. Okay. [laughter] I was a ringleader already. [laughter] But I think focus—having a goal—is important. Now my goals have changed every year almost. [laughter] Not quite. But being focused on something is important.

GRAYSON: Were there any...I mean, so you're going to school, getting a good education, a lot of reading. Somewhere along the way, science...

FUTRELL: Excuse me. I wouldn't say it was a good education. [laughter]

GRAYSON: Oh, well...a broad education.

FUTRELL: A broad education.

GRAYSON: But somewhere science...you became I assume interested in science over other subjects that were...

FUTRELL: Yes. Actually, many years later in my career, when I was a department chair, we started inviting alumni back. And so at some point...gee, I guess it was around 1990 or thereabouts, we had a big gathering of alumni of the chemistry and biochemistry department at the University of Delaware. We did a little questionnaire to ask all of them how they got interested in chemistry, science in general first, and then chemistry in particular. And almost always it's because we had had a chemistry set, okay? So, you might recall the name Chemcraft. By the time I was in the second grade, I think, Santa Claus—whom I didn't quite believe in, but I wouldn't say that I didn't believe in Santa Claus—Santa Claus brought me a chemistry set. And so that clearly was my first exploratory science. And we can't sell these anymore. It's you know...

GRAYSON: I know. They're hazards.

FUTRELL: They're a hazard. And that's why there's been such a drop-off in interest in chemistry. [laughter] I'm not serious about that.

GRAYSON: Well, I'm not...

FUTRELL: But there's an element of truth.

GRAYSON: There is an element of truth, I think, because it feeds an early curiosity, which maybe becomes not so easily satisfied with the chemistry set [...].

FUTRELL: That's right. That's right. And I wasn't satisfied in chemistry sets, and so I went well beyond the contents. I extracted plants. You know, I extracted grasses and leaves and fruits. [laughter] And you could buy acids and bases, you know, and I did all kinds of weird things. Of course, explosives are...

GRAYSON: Oh, sure.

FUTRELL: ...key entrants. [laughter] My first explosive creations were taking firecrackers apart.

GRAYSON: Oh, okay.

FUTRELL: You know, I don't want to describe officially. [laughter] How big it got, or the fires that got started. [laughter]

GRAYSON: So this interest started somewhere around what age, would you say?

FUTRELL: Oh, the second grade.

GRAYSON: Second grade. Wow.

FUTRELL: So, I'd have been probably seven.

GRAYSON: That's kind of advanced, to give...

FUTRELL: Seven or eight.

GRAYSON: ...a chemistry set to a second grade kid. That's a little scary.

FUTRELL: [Yes]. It was my mother's sister, my aunt—my favorite aunt, Aunt Lucille. She, you know, sent me lots of things from California that gave me either a temporary or sustained interests that were different from my classmates.

GRAYSON: Interesting.

FUTRELL: In high school, interestingly enough, because the teachers got assigned subjects to teach that did not necessarily reflect their aptitude. So, I actually got to teach the chemistry class when I was a student—supposedly a student in chemistry. I got to do all the lab experiments and teach a significant part of the course.

GRAYSON: Because the, quote, chemistry teacher was not all that interested in [the subject matter]

FUTRELL: [Yes], she was afraid of chemicals, okay? [laughter] And I was fearless. [laughter]

GRAYSON: So how big a class did you have?

FUTRELL: Oh, it was about twenty and I didn't kill anybody. [laughter]

GRAYSON: Did you actually give out grades, then?

FUTRELL: No. No, they didn't delegate that to me. [I could give lectures, perform demonstrations, and grade papers, but not assign grades. I did receive an A+ for my efforts.] My class had twenty-one students <T: 25 min> when we entered high school, and thirteen when I graduated. I was valedictorian. Very small sample. But anyhow, our high school, consolidated high school, was a class C school, and I guess that, you know, depends on size primarily, and courses taught, and things like that. A class C school, because we, among other things, didn't have a gymnasium or a swimming pool, but there were outdoor basketball courts. And our team, the one that my classmates, the big guys, tall guys, the class ahead of me and the class behind me, were on a winning team. So for two years, Dry Prong High School was state [basketball] champions of class C high schools.

Well, I could write and take notes, and so I was the mascot that traveled with the team all over, and got to visit many other towns in Louisiana. The other thing that may not be unique but was interesting practice in Louisiana is they had scholastic rallies as well as the athletic rallies. And so beginning in my freshman year in high school, there would be regional contests where you would take exams in different subjects, and then after the regionals, the winners from that would go to the state scholastic rally that was always held in Baton Rouge, where LSU [Louisiana State University] campus was, and the state capital. So, beginning my freshman year, I won gold medals in every subject. I singlehandedly, not quite, but I was certainly the star of the scholastic team. And so I had...

GRAYSON: Was there anybody else on the team? [laughter]

FUTRELL: There were several other [smart] people, you know, who went to the regional rally, and a couple others went to the state, but I was the gold medalist, so I picked up I think twelve medals altogether. Each of them came with a full tuition paid scholarship to attend LSU, and at one point, I asked if they would add them all up and give me the cash. [laughter] But they didn't do that. And so I said, "Well, I'm not going to go to LSU." But they don't understand the American dream.

GRAYSON: Although they were offering you the education, you decided that since they wouldn't you know make it a lucrative deal...

FUTRELL: They wouldn't deal. They wouldn't deal.

GRAYSON: They wouldn't deal. [laughter]

FUTRELL: They wouldn't deal, so I wouldn't go. I learned much later that other scientists more famous than I had practices like that. One of my favorite persons I got to know well was Henry Eyring, many years later, and he had offers to go to every school. He chose Berkeley because they outbid the University of Chicago [stipend] by ten dollars a month.

GRAYSON: Oh, wow. Interesting.

FUTRELL: Well, you know, at an early stage in my...maybe at all stages in life, you made decisions for crazy reasons, that don't make sense when you look back at them.

GRAYSON: So, when you passed up LSU, obviously, you went to college, so what...

FUTRELL: Yes. Well, I won many other contests, scholastic kinds of things, and so I had lots of options, but I [...] despite my trips to California, I didn't feel brave enough to go to the biggest cities and big schools and so on. I had the sense to understand that being the, maybe, smartest kid in a class of thirteen doesn't guarantee success at the Big Ten schools. At least I understood that. And I had [...] several teachers [to advise me]. Actually, my math teacher had a degree in mathematics as well as education, and **<T: 30 min>** he had actually taught at college for a while, and then got bumped down and somehow ended up teaching at Dry Prong. And he had some social problems, but he let me have his college textbooks, so those were among the books that I started reading as either a freshman or a sophomore, I've forgotten which, in high school. And that was, you know, part of the key to outscoring the competition, probably, is I was [studying several] college level books. [...]

But anyhow, there were several teachers that gave me unusual degrees of freedom to give lectures and assist in the teaching process, but my favorite was a teacher who lived down the street—actually, it wasn't a street. It was a dirt road about two miles from my house. It was the wealthiest family in our very poor neighborhood, and they owned a cow. And so I would pedal my bike down and buy milk from this lady who became a teacher of mine in high school.

And she had a son two years younger than I was, and so he was a playmate, because there were so few people in the neighborhood, you sort of ran with older and younger kids as well.

I got to know her, and she invited me to visit her alma mater. It turns out that she was an orphan raised in an orphanage in Ruston, Louisiana, where Louisiana Tech [University], Louisiana Polytechnic Institute, is located. And as a person living in the orphanage, you were somehow automatically given the option of attending college for free. And so you would stay on at the orphanage when you were college age, and then they had a bus that they would run back and forth to the local college. So, she graduated from Louisiana Tech [and] she invited me to go up and see the school, probably three or four trips while I was in high school, one of which involved an engineering barbecue cookout, which impressed me. And so that was the school that I felt I understood and I was comfortable with and they also gave me a couple of scholarships. And let me see, another socialist thing, if you graduate the top of your class and meet certain other criteria, you qualify for the Thomas H. Harris Scholarship in Louisiana [that paid about half your expenses to attend a state college or university].

And finally, my parents, who encouraged my education from the day that I was born, despite their financial problems, they set aside ten cents per day. Okay? And so I had about five hundred dollars in my college fund. They had assumed I'd spend one year, you know, learning something, bookkeeping or something useful, maybe go to a trade school, and that would be enough. It was a surprise to them that I decided to go to college. And so with five hundred dollars cash and a couple of scholarships, I headed off to Louisiana Tech.

GRAYSON: This is in Ruston?

FUTRELL: Ruston, Louisiana. So [I entered the] freshman class [at Tech, a] freshman class, that—back in those days, hazing was very common. I don't know whether you encountered that, Mike, or not.

GRAYSON: Hmm. No.

FUTRELL: Maybe Yankees had already moved beyond that.

GRAYSON: [Yes]. I think it was more of a fraternity thing, if you, you know, joined a fraternity.

FUTRELL: Yes. Okay. Well, at Louisiana Tech, the freshmen had to have their heads shaved and they wore a cap. I'll bet that Anne [Futrell] could find it. [laughter] So, maybe you want a

photograph. [laughter] So, I had to wear this cap over my shaved head, identified me as a freshman, and any upperclassman could stop me on campus and have me do calisthenics.

GRAYSON: Oh, wow.

FUTRELL: Carry their books, you know, all <T: 35 min> kinds of degrading things.

GRAYSON: Was this a coeducational school?

FUTRELL: Yes. It was coeducational. But just barely. It was really an engineering school, and it was fully accredited, and that was the other fact, that I was majoring in engineering—chemical engineering to be specific, because I had checked and found out that the starting salaries for a bachelor of science chemical engineer was the highest of any college degree at that point in time. And I, you know, thought, continuing to travel to California would be a good thing.

GRAYSON: That point in time would have probably been early 1940s or mid-1940s?

FUTRELL: What?

GRAYSON: The time when you entered college?

FUTRELL: Oh, no, no. It was 1951.

GRAYSON: 1951. Okay.

FUTRELL: And that was—1951-1952 was the year of hazing and so on. But among other things, if they saw you frowning, then you'd get to do a second set of push-ups, and so you had to smile and be happy. [laughter] And you also were expected to speak to everyone. So as you walked across campus, you would speak to everyone. Hello, good morning, have a nice day, and so on. So there were certain aspects of that that were very, very good for college students. [laughter] You know, years later as a professor, if I could have forced the freshmen to do that...

GRAYSON: [Yes]. Interact more.

FUTRELL: Interact more. It would have been a good idea.

GRAYSON: I thought either you smiled a lot or else you got strong doing push-ups. [laughter]

FUTRELL: I found it easier to smile. Pushups were not my strong suit.

GRAYSON: So, about the name of this woman that had...

FUTRELL: Oh, Vera Guynes. Yes. [...] She taught history, I think it was American history, and I won a gold medal in American history. [laughter]

GRAYSON: But her influence on you primarily was getting you pointed towards this...

FUTRELL: Getting me pointed toward the school and getting some acquaintance with it.

GRAYSON: Now you say she went there?

FUTRELL: Yes.

GRAYSON: Okay.

FUTRELL: She was an orphan, and as an orphan she attended school. Later on, she got married, moved to Grant Parish, [Louisiana]. Her husband was a forest ranger in Kisatchie National Forest. And because he had a federal job, he had money, and so he had a steady salary. And also his farm was not invaded for CCC, Conservation Corps, or the military.

GRAYSON: Was there any compensation for the CCC taking the property?

FUTRELL: I suppose there was.

GRAYSON: But not an adequate amount that...

FUTRELL: No, and it got dissipated, as I later learned, by my parents feeding people for free, so to speak, for some number of years—helped them get on their feet. This actually came out at my father's death, because there [were so many] people who came to the funeral. I was amazed, in his very small [town in] rural Louisiana, there were [...] well over one hundred people who attended his funeral, and I learned much more about what my parents had done, my father most notably, that I was just blissfully unaware of growing up.

GRAYSON: Well, I'm sure you were young and didn't know what was going on.

FUTRELL: Sure.

GRAYSON: So, he gave a lot of hands up help?

FUTRELL: Lots of handouts to other people. He was certainly one of the most honest persons I've ever met. We lived twenty-five miles from the nearest town of any size, and thirty-five miles from Alexandria, [Louisiana], which was the only town large enough to have a hotel. And that's where the cotton gin was. And so we would carry cotton down there. That's where I first got my first hamburger as a kid, with French fries, curly fries, actually.

GRAYSON: Oh, wow.

FUTRELL: With curly fries. That was a big deal. But I remember once going with my father, and he counted his change about fifteen miles back, and he had been given something like thirty cents too much, and so <T: 40 min> he reversed course, drove thirty miles round trip, to return the change.

GRAYSON: Wow.

FUTRELL: So, you know, first time that...

GRAYSON: Made an impression.

FUTRELL: Made a real impression on me.

GRAYSON: I need to get the names of your parents, now.

FUTRELL: Oh, okay. My father was Homer Elmore Futrell. My mother was Ellen, [...] Catherine, and her maiden name was Padgett. Her father was James Alfred Padgett, who came to live with us, and he brought some money to the family, because he was a Spanish-American War veteran, and he had a pension. And then somewhat to my disappointment, invested the money he had in a chicken farm, okay? And so we raised chickens. I don't know how many, but to a small boy it was lots of chickens. And they're nasty. [laughter] They were in chicken coops that had chicken wire, and, you know, the droppings, and guess who got to clean out the...

GRAYSON: Right.

FUTRELL: I had my series of chores growing up. There were all these eggs, and chickens are cannibals, you know. If one gets a bleeding sore, then they get attacked by the other...and chicken eggs and chickens, chicken eggs, is an attractor for snakes. If you yell snake, I'll jump, even today. [laughter] There were countless times I saw a snake with three eggs working its way down the body. And it was of course my job to get a long pole and kill the snake. Also, we ate a lot of chicken.

I like chicken again, but many, many years... [laughter] [later, as a college graduate.]

GRAYSON: Took a while. Took a while.

FUTRELL: It was my job to kill the chicken [we were eating for dinner].

GRAYSON: Oh, no.

FUTRELL: It was my job to dunk it in boiling water and pull off the feathers. It's *so much better* to go to the supermarket. [laughter]

GRAYSON: What execution method did you use?

FUTRELL: An axe.

GRAYSON: The axe? Okay.

FUTRELL: I think I have it in the garage. [laughter]

GRAYSON: So you actually...we talked a lot about your education and schooling, but you...you spent a lot of time on the farm doing farm chores.

FUTRELL: Sure. Sure. Had lots of chores. And we did not have electricity when I was growing up, so I burned a lot of kerosene to read the books. In the daylight hours you're out working, and then you had a kerosene lamp [for reading, studying, writing after dark]. The other thing I resented was having to cut wood for a potbellied stove in the center of the house—nowhere near my bedroom. It was cold. And, you know, going with my father [to cut wood]. Khaki clothes are extremely cold in the winter. [laughter] So, starting with a big saw, and, you know, cutting down these trees, and making smaller pieces. Again, my trusty axe was a way to convert blocks of wood into small pieces of wood. If you look in the garage, you'll find I now buy it at the supermarket. [laughter]

GRAYSON: Yes.

FUTRELL: But anyhow, it was a good life. It was a great life, growing up. My grandfather Padgett was at one time the only registered Republican in Grant Parish, Louisiana. He was from Illinois, the Land of Lincoln. And I remember in a civics class they assigned us the job of going to a polling booth to observe democracy in action, and so I stayed for the counting of the ballots and everything. And there was one vote for a Republican candidate for President, and they had a discussion whether it was legal to vote Republican or not. [laughter] And I assured them it was. [laughter] I didn't tell them I knew who it was. But I guaranteed them that it was legal and if they didn't count it, I was going to report it. [laughter] <T: 45 min> Now I think they're all Republican.

GRAYSON: Oh. [laughter] Amazing.

FUTRELL: And did I tell you my grandparents didn't agree with each other?

GRAYSON: Oh, no. [laughter] The ones on different sides of the family?

FUTRELL: They were from different planets. [laughter]

GRAYSON: This must have been exciting.

FUTRELL: It was. It was interesting. And that, you know, helped me broaden my understanding of lots of things, I'm sure. And they were—they were so different. You know, we had one house, and they...you know, my father built a second bedroom for my mother's father, just tacked it onto the house. But that didn't work. So, when the chicken farm was created, my Republican grandfather moved across the street into his own cabin, and just to complete the nonsense, my other grandfather built another cabin so I could visit them each in their [own] house, to be indoctrinated. [laughter] As well as having the house I lived in with my parents. My mother was a saint. [laughter] How [my mother] put up with that is beyond my understanding. [laughter]

GRAYSON: Oh, Lord.

FUTRELL: So I was interested in civics. I got different slants on the Civil War and so on from my early youth. [laughter]

GRAYSON: I can imagine. Oh, wow.

FUTRELL: It was the damned rebellion and it was the defense of states' rights. [It was certainly different thing to different people.]

GRAYSON: Well, it certainly gave you an opportunity to see different sides of any particular issue, that's for sure.

FUTRELL: Yes. That's right.

GRAYSON: Which probably is...

FUTRELL: And that really proved useful as you grow up.

GRAYSON: Boy, you...

FUTRELL: So, I went to college, Louisiana Tech. The reason that my [high school] graduating class decreased to thirteen is that the Korean War was going on, and [some of my male classmates] were eager to volunteer, and they allowed you to volunteer with your parents' approval. And so they went off to the war, and I went off to college—turned eighteen [in my freshman year]. In Louisiana—well, I guess throughout the United States—there was a special examination that was given to guide draft boards in giving deferments, because as a matter of national policy, they felt it was useful to defer some of the best students for higher education, and I was already doing well at Louisiana Tech in my classes. I had to drive, oh, one hundred and twenty miles or so to Shreveport, Louisiana, nearest city where the exam—I've forgotten what it was called—the Selective Service Qualification Exam [was given]. And I remember that I had a cold or flu of some kind. I was running a low grade fever, roughly 100, 101, [that] I controlled by aspirin. I was coughing, sneezing, [and] infecting the other [guys] who were taking the test. I was off my game, and so I was concerned that I might not do all that well. [So,] I was surprised later on to [learn from] my draft board in Grant Parish, Louisiana, Town of Colfax, which was where the Futrell Bank and Futrell Hardware Store and all those other things were located, along the Red River, county seat of Grant Parish. The draft board sent me this [state of Louisiana Selective Service] newsletter [...] that announced that this kid from Dry Prong had achieved the highest score in the state [...]. So, I said, "Well, [now that is really good news.]" By this time, I understood enough of <T: 50 min> kinetics, you know, that maybe having a low grade fever is good to be able to think faster and so on. [laughter] I've never proved that theory. But anyhow, I was very pleased, and very surprised [a month later] when I was classified 1-A. So, I went to see my draft board [during our Spring break]...

GRAYSON: What's this about?

FUTRELL: ... to ask what's going on here?

GRAYSON: Because that would be the...you know, [ready] to be drafted.

FUTRELL: Oh, [yes]. Ready to go. I met first with the secretary of the board, then I met with the person who was the chair, president, I guess, of the Selective Service Board, whatever it was—Director, maybe. And I said, "There's got to be some mistake." He says, "Oh, no. Oh, no. In our experience, if people get one year of college behind them, they get away from us." [laughter] So, I won't use the language that he used on me, but he made it very clear that I would be in the service in short order. Well, so I went back, and patriotic American that I am, I talked to my algebra teacher that I had gotten to know.

GRAYSON: This was in college?

FUTRELL: In college. Yes. I already knew algebra, and so I got to be friends with him. And he was a colonel in the [Louisiana] National Guard. And so he talked to some of his contacts, and [following his advice] I was allowed to enroll in the [Air Force] ROTC [Reserve Officers' Training Corps] at Louisiana Tech a year late. I should have made that decision as a freshman.

GRAYSON: Sure.

FUTRELL: But I didn't. I made the decision [after] I was inspired by my draft board, I guess, to join the Reserve Officer Training Corps. It was Air Force, Air Force ROTC. And so, I had to do two years of ROTC classes simultaneously, while I was a chemical [engineering student] loaded down with courses and labs. I had to have double time in ROTC, but I also was taking extra courses in physics and, actually, in speech. Lots of girls in speech classes. [laughter]

GRAYSON: You were carrying probably...

FUTRELL: I was carrying a heavy load. About, oh, thirty percent more than the most of the [other students].

GRAYSON: Eighteen, twenty plus hours.

FUTRELL: About twenty-two hours in that year. I was busy, okay? But straight As, no problem. And so, I was doing well and enjoying life. I actually added hosting the campus radio [Friday night] talk show for various reasons, including meeting people who were not engineers, and also [enjoying about three hours in] an air conditioned building.

GRAYSON: Ah, there you go.

FUTRELL: And, well, those were weird experiences, broadening experiences, let's say. If you have invited speakers with no knowledge of their background and you have to catch up and fill in and, you know, play recorded music if necessary. [laughter] Bring things to a close. So, I had a wonderful experience at Louisiana Tech. [In the military drill part of ROTC classes, because they sized people and promoted people on the basis of height, I was short enough to march in back, and so I never got heavily involved in ROTC until, again, there was a nationwide thing to try to identify let's say scholars, and their disciplines, and the upshot of that, another test. And I

won one of four Armed Forces Chemical Association awards, which involved a medal, which I have somewhere, I think. <T: 55 min> [I was the only Air Force cadet in the US receiving the medal, based on my scholarly achievements and chemical knowledge. The highlight of this honor was a military parade, complete with marching band, and presentation of the medal in the stadium by General MacArthur who flew down from Washington, D.C. for the event.]

No, sorry to put that in the record. It was *not* Douglas MacArthur. But a General MacArthur came out to make the award, and there was a special parade in my honor, and so on. And I became recognized. I was promoted to...let's see, from cadet corporal to cadet lieutenant colonel. [A big deal for me and AFROTC at Louisiana Tech, unnoticed by the rest of the world.]

GRAYSON: Wow. [laughter]

FUTRELL: And again, that was not much of a problem, because I got to just walk around with the people carrying the flag in parade ceremonies and so on. And then disaster struck. The cadet colonel flunked out of school [in his senior year], and I was the head man in charge.

GRAYSON: Oh, no. [laughter]

FUTRELL: So, I had to read the [drill manuals] all night long to learn [about marching, giving commands,] parades and so on and so on.

GRAYSON: Ah, get all the military stuff.

FUTRELL: And so on. Yes. And then I went to ROTC summer camp, and I was the camp commander.

GRAYSON: Oh, boy.

FUTRELL: So sudden elevation to [leadership]...sort of first experience in my life, suddenly being elevated to a strange position of authority. Summer camp was at Lackland Air Force Base [in Texas].

That's in between the junior and senior year. My roommate in college from my freshman year onwards was a chemistry major, and by this time, I couldn't keep up with all the courses, and so I dropped all the extra subjects. I was just a chemical engineer, and, you know, president of this

and that, student clubs [both American Chemical Society and American Institute of Chemical Engineers student chapters]. I had a roommate [Alva Schoomer,] who had decided he was going to go to graduate school. He had decided that he was going to be a [research] chemist. And he had done enough research that he had selected Berkeley—University of California, Berkeley—as the place he was going to school. And so I decided I would go to graduate school also. In the meantime, I had had summer jobs in various places, including Baytown, Texas.

GRAYSON: Sure.

FUTRELL: Where I had actually met Joe [L.] Franklin. I talked to Joe [L.] Franklin, who was director of research and I didn't know any better. I just went and knocked on his door and said, "Hello, I'm a summer student." [...]

GRAYSON: Wow. So you were working at Humble Oil in...

FUTRELL: Humble Oil and Refining Company in Baytown, Texas. And I actually was working on catalytic conversion of very gunky oil into something that could be processed into more valuable chemicals.

GRAYSON: Sure.

FUTRELL: And it started out as a cookbook to find out which catalyst was best...done in a small laboratory experiment. But they had a huge analytical laboratory at the Baytown refinery, Baytown Research Center. And so I actually got to look at a mass spectrometer from a distance. NMR [nuclear magnetic resonance] was a new thing that was getting started, and because I had a certain level of curiosity that probably was beyond what was expected of summer students, I asked these guys to run samples for me, and so they did. And so, I had crude chemical structure information, what happened in the catalysis process. I wrote a patent disclosure about it, wrote a couple of internal reports for Exxon, the greater corporation. Much later on I learned that [...] my reasoning wasn't good enough to justify the [conclusions]. But it was still my first...what should I say: exposure to a serious research lab, and serious [research scientists].

And <T:60 min> Joe Franklin recommended that I get a degree in chemistry, PhD in chemistry, and that would be ideal preparation for an industrial research career. Chemical engineering, bachelor's degree, PhD in chemistry. [Sounded good to me as a career path.]

GRAYSON: Sure.

FUTRELL: And at that point in time, I read that the DuPont Company [E. I. duPont de Nemours and Company] in Wilmington, Delaware, had appointed as their president and CEO the first person who was not named DuPont. And this was a person who had a [chemical engineering degree from MIT [Massachusetts Institute of Technology]]. There you are. So, I decided maybe I'd be president of DuPont. Why not?

GRAYSON: Why not? [Yes]. What the heck?

FUTRELL: So, with that foolish thing in mind, and with my roommate, who was the top student in chemistry, but there were just a few people majoring in chemistry, lots of chemical engineers.

GRAYSON: Lots of chemical engineers.

FUTRELL: [Yes]. So I think there were twenty-eight or so in my class, who got AIChE [American Institute of Chemical Engineers] accredited degrees in chemical engineering. And I decided I should go to CalTech [California Institute of Technology], because they would [likely] recognize my engineering degree as having some significance [and there was this guy named Pauling on their faculty in chemistry].¹ But with my rail pass, I could visit Boston, [Massachusetts], I could visit Chicago, I could visit San Francisco Bay Area, and Los Angeles, [California], and then go to Lackland Air Force Base, report for summer camp, ROTC. And then I would come back and explain my findings to my roommate, who had done the literature search and made his decisions.

GRAYSON: You were going to do a real visit kind of thing.

FUTRELL: [Yes]. I came out for an interview, like you came out here, you know.

GRAYSON: Sure.

FUTRELL: To get the real truth behind the [image].

¹ See Linus Pauling, interview by Jeffrey L. Sturchio at Executive Tower Inn, Denver, Colorado, 6 April 1987 (Philadelphia: Chemical Heritage Foundation, Oral History Transcript # 0067).

GRAYSON: So, these train passes, you just have to flash...[do] you have to pay anything, or you just say, "Here's my train my pass and..." ?

FUTRELL: No. You can be bumped if there's a paying passenger.

GRAYSON: Okay. All right. All right.

FUTRELL: So, if a seat's available, free ride.

GRAYSON: Okay. Okay. But basically, you got around for nothing?

FUTRELL: [Yes]. Go around for nothing. And so it was a good deal. That was not a good year for my father, because he was actually fired a few months after this happened, because if they had kept him one more year, he would be qualified for pension rights, okay? It turns out that was not uncommon. My wife's father was fired at the same age, because again, if they pass that anniversary then they get special rights that don't exist if they lose their job. So I suddenly was worried that I would have to drop out of school and so on to help support my parents. But they took care of themselves, and that was an important message, that, you know, I think the best thing that we can do, Mike, you and I, and people our age, is not be a burden to our second and third generations after us. So, somehow take care of ourselves. And my parents did that.

Anyhow, I reported on my interviews and verbal findings [to my roommate]. When I visited Berkeley, they had a college of chemistry that had chemistry and chemical engineering in the same department, something I tried to create in several other places, never succeeded, but it's the right organization. I still think so. And Kenneth Pitzer was the dean of the College of Chemistry. Kenneth [S.] Pitzer, world-famous thermodynamic spectroscopy person, later president of Stanford University. And he was in charge of a significant part of the wartime research effort. I think Henry Eyring might have headed a research group working for him. Anyhow, big, big shot. And so I waltz in as this kid from Louisiana Tech, knock on the door. [laughter]

By the way, [when] I went to MIT, they were not so impressed with me. I looked at Harvard Yard and said, "Well, I don't want to do that." I stopped in Chicago. I liked the people at the University, but I didn't like the surroundings.

And I went to Berkeley, and I rapped on the door <**T: 65 min**> and introduced myself, and Kenneth Pitzer, Dean of the College, spent more than an hour of his time, maybe two hours, showing me around...

GRAYSON: Wow.

FUTRELL: ...introducing me to people. And, you know, that clinched it. So, right then and there I decided I would go to Berkeley, but I completed my journey, going to Caltech, and I dutifully insisted on meeting Linus [C.] Pauling. [laughter]

GRAYSON: Oh, there you go. Well, why not? I mean, you're there. [laughter]

FUTRELL: And they were courteous, but they didn't take me under their wing and show me around [and they did not disturb Professor Pauling].

GRAYSON: Didn't treat you like...

FUTRELL: I went back and I reported to my roommate, and, you know, in detail, and—and so I said, "So it's great news. We're both going to Berkeley." He said, "Nope, I'm going to Caltech, and I'm going to work for Linus Pauling." [laughter]

GRAYSON: Oh, wow.

FUTRELL: And he did. He was the first one of Pauling's students to use a computer to deduce an x-ray structure. He went heavily into computers—in the mid-1950s— when it was very, very difficult to do. Very difficult challenge. And so on. So, he went to Caltech, and we didn't get to spend our time together. But [Pasadena was close enough to Berkeley, that] we got together a few times during our graduate careers.

GRAYSON: You want to mention the name of your friend, or...

FUTRELL: Oh, Alva Schoomer, [...] Bertrand Alva Schoomer.

GRAYSON: Alva.

FUTRELL: He went by the name of Alva or Al, but usually Alva.

GRAYSON: Oh, okay. Schoomer. Very good.

FUTRELL: Yes. He and I kept in touch for many years. It's been almost a decade since I heard anything from him, and when I punch him in on the internet, I don't find him. So I suppose, like many other people in our general age group, he [may be dead]. He had an interesting career, was a millionaire a couple of times, had a seat on the New York Stock Exchange, because he went to work for Arthur D. Little after he got his PhD He applied some of the same computer skills and principles and non-linear extrapolation of trend lines [to stock prices and investments rather than X-ray intensities].

GRAYSON: Kind of pioneered in that business.

FUTRELL: [Yes], he did. He was a pioneer in that. [And I deviated from my career path as well.] Despite my declared ambitions to become [president of a major chemical company], I actually fell in love with molecules. [laughter]

GRAYSON: Oh, we've got a problem here.

FUTRELL: [A real] problem. [It came about because] I knew I'd have to be a physical chemist, because that was the closest part of chemistry to chemical engineering. Thermodynamics was a big deal, and I had a year of chemical engineering, thermodynamics, a year of chemical thermodynamics, and a little statistical mechanics thrown in for good measure. So, until I got to Berkeley, I thought I knew thermodynamics.

Well, you know, if you're taught by Kenneth Pitzer, [whatever you have learned in your past life may not be enough]. And my classmates [were pretty bright]. I neglected to mention, I think, that I won a NSF [National Science Foundation] graduate fellowship [the first year they were awarded]. When I applied to graduate school, I decided on Berkeley, and I foolishly thought they would immediately accept me, so I didn't bother with any other school. And I was absolutely correct. I got an airmail letter within a week accepting me in the Department of Chemistry, College of Chemistry, appointing me a teaching assistant, appointing me a distinguished scholar, which according to State of California rules exempted me from out of state tuition, and that they were looking forward to my joining them.

GRAYSON: Oh.

FUTRELL: I thought that was very, very nice. I waved it around, you know, <T: 70 min> to my roommate, who hadn't heard from Caltech yet. And then I got the surprising news, after another exam, nationwide exam, that I had won [an] NSF graduate fellowship. [...] I think there were something like twelve who chose chemistry as their major, who won these fellowships. There were [only] two of us from south of the Mason-Dixon Line. And when I got to Berkeley, I found six people also had NSF graduate fellowships, one of whom was John D. Baldeschwieler...²

GRAYSON: Oh, wow.

FUTRELL: ...a name that you will recognize, probably. There were some other people in class who had come from schools like John's. [...]. It was either Harvard or MIT, but I think it was Harvard, where John had received his [BS degree]. And as I said, [...] virtually half of the NSF graduate fellows in chemistry were in my graduate class, and so I was no longer the brightest kid in class. That was a useful revelation to me. [laughter] And John in particular and three or four other people dominated the conversation with Kenneth Pitzer, because [...] his lecturing style was the [exceptionally informal]. He [assumed we] read all the assigned reading matter and worked all the problems. "Do you have any questions?" [laughter] And, you know, the first time there were no questions. "Is there anything in chemistry at large you'd like to discuss?" No. "Class dismissed." Well, people started taking him on, you know, and so it was a wide-ranging discussion of chemistry topics—and almost no thermodynamics was discussed in [his] thermodynamics [course].

GRAYSON: Like seminar, sounds like.

FUTRELL: [Yes], it was. It was a seminar under a different name, by a different name. And so I was, you know, slightly intimidated. We had a midterm exam, and having, you know, had two and a half years of thermodynamics already, I was pretty confident, but I didn't do as well as I had anticipated. And I went to see Dean Pitzer again. I was getting to know him at this time. And I said, "Not a single question had anything to do with any of the stuff that you have assigned," and so on. "I don't get this. I could do any of those. I have done all of them." He says, "That's not what we're looking for." He says, "We expect, you know, if you've done everything we've assigned, that you've learned how to fry an egg, and if you've engaged in some class [discussion] in an appropriate way, that you could make an omelet. And on the exam, we ask you to make a soufflé. That's our philosophy of education." [laughter]

² See John D. Baldeschwieler, interview by David C. Brock and Arthur Daemmrich at Chemical Heritage Foundation, Philadelphia, Pennsylvania, 13 June 2003 (Philadelphia: Chemical Heritage Foundation, Oral History Transcript #0280).

GRAYSON: Nice guy.

FUTRELL: [Yes]. He was an extremely nice guy. [The good news is I got calibrated and joined in the seminar debates, started reading journals, etc.] The other guy from south of the Mason-Dixon Line flunked out. [laughter] And I learned to make omelets.

GRAYSON: Or soufflés.

FUTRELL: And soufflés. And so on. So, I learned. You had to read the current literature. You had to, you know, think about things, turning them upside down, and backwards and so on. It was an invaluable experience.

I, also, my first semester, took a class called advanced mathematics for chemists and chemical engineers [taught by a new faculty member Andrew Acrivos]. [It was] difficult to understand his accent. I, you know, took the class. I studied hard. And we had the first exam, and I think my score was <T: 75 min> 35 or 36 percent, something like that. Worse than my thermodynamics score. I knew my fellowship was in jeopardy, and so I went to see [Professor Acrivos], sat outside his office waiting for the conference hour, knocked on the door, came in, much meeker than I was with Dean Pitzer. The [score on his exam] was lower, and I didn't know this person at the time, so I introduced myself, and he says, "Oh, Futrell." He shook my hand. "I'm so glad to meet you. You had the highest score on my exam." [laughter] "Help me in my teaching."

GRAYSON: Oh, there you go.

FUTRELL: I felt better. [And I made an A and a new friend.]

GRAYSON: [Yes]. So, 36 was high.

FUTRELL: It was the highest score. Now that figures into my own teaching career, because later on, in my first exam given at the University of Utah, the highest score was 37.

GRAYSON: Oh, wow.

FUTRELL: But by this time, I knew the problem and could deal with it, so...

GRAYSON: Very interesting.

FUTRELL: It was a real shock to switch to a Berkeley system. They had a Tuesday evening seminar where, you know, people would come into the meeting from wherever they were. Joel [H.] Hildebrand was the elder statesman in the department, [an] inspiration to me in ways that he would never know. [...] I guess he was in his late sixties, maybe early seventies. He'd come clomping into the Tuesday evening seminar in his ski boots. And, you know, I never had a class with him. He wasn't teaching. He had retired, or was emeritus status, and still had graduate students. He published almost as many papers after he retired as prior to that time.

GRAYSON: Wow.

FUTRELL: Still very active in research, but he didn't take graduate students. He had postdocs and visiting scholars working with him, and he was President of the American Chemical Society [ACS]. And so, I was eligible to join the American Chemical Society. I'd been president of the college chapter of students, affiliates. Actually, I was president of both AICHE and the ACS student affiliates. I was ready to become an adult member of the American Chemical Society, and I asked Joel Hildebrand if he would nominate me for membership. You probably recall [the ACS nomination for membership] requires two names, and so I told Professor Hildebrand, "Please sign President, ACS, underneath this line. I want to send it in without a second nomination." And he thought that was a fun thing to do. So, we sent it in to the American Chemical Society, one of our revered professional societies—I'm an ACS Fellow [inaugural class of ACS Fellows in 2009]. I'm totally loyal, okay? [...] But ACS being the ACS, they sent it back for a second name. [laughter]

GRAYSON: Didn't matter who you were.

FUTRELL: Doesn't matter.

GRAYSON: Don't pull rank on me.

FUTRELL: [Exactly!] I picked out a plausible Nobel laureate and asked him to [recommend me.] I may have asked [Glenn T.] Seaborg to sign it. Actually, [I] was probably nominated by Joel Hildebrand, seconded by Glenn T. Seaborg, and then I was good enough for the ACS [to accept me as a member].

GRAYSON: There you go.

FUTRELL: And they allowed me to join the Society. So anyhow, when I went to Berkeley I assumed that I'd work for some of their people who were doing kinetics or thermodynamics. I actually thought that I might work for William F. Giaque, third law thermodynamics person. I had read some of his papers. They were quite easy to understand, and so on. And I had him as an instructor in the second term called Advanced Topics in Physical Chemistry. And <T: 80 min> he was way too formal for me, so I decided that I didn't want to work with him. And radiation chemistry, radiation physics, of course, the accelerators, what was then called University of California Radiation Lab, UCRL, was on campus. And so, I included a tour and saw what was going on in Seaborg's laboratories. The chemistry building was essentially Seaborg's greater laboratories there. But I was not interested in doing nuclear chemistry.

GRAYSON: Sure.

FUTRELL: I had decided even then that there were way too many...and the Nobel Prize has already been awarded [to Edwin McMillan and Glenn Seaborg, Chemistry, 1951], so I decided radiation chemistry, [studying the] chemical effects of radiation, was what I wanted to do. And so I dutifully signed up to do that, and immediately when I had the safety course that was required to work in this laboratory at UCRL, I knew at once I made the right decision. Of course, the people who were working with highly radioactive substances had to work in glove boxes,[or utilize] remote manipulators [to process highly radioactive targets].

Professor Cunningham, Burris B. Cunningham, I remember him primarily because of that safety lecture he gave to us. He showed a glove box to us, and the student working there, and another student was standing by. He says, "This is the message, folks. You never, ever work in the glove box alone. You deal with everything remotely." And he had us stare through the glass to see what they were doing. [...] He said, "Now what you see is this person is using a very sharp glass pipette to transfer a substance from one vial to another, and this is in a strange sense one of the more dangerous maneuvers, because [...] if you have trouble getting it in through this light rubber stopper, it might break, and depending on how the glass shatters, it could penetrate this rubber glove. That's the reason there's a fire axe mounted beside this. If you're the partner, it's your job to cut off his arm...preferably the one that's been stabbed." [laughter]

GRAYSON: Oh, wow.

FUTRELL: "If not, cut off the second arm because you have a short period of time to save your partner's life." Well, he may have been exaggerating. I hope he was.

GRAYSON: It made the point.

FUTRELL: He made the point. And I knew I had made [a good decision].

GRAYSON: No messing around with this stuff.

FUTRELL: No messing around. No messing around with that. So, I became a radiation chemist, and part of the tale is that Seaborg knew it was important, but he wasn't [personally] interested in it, and so I was left to my own devices. That was true of probably many, many graduate students at Berkeley. They were kind of on their own, and we learned from each other. And because my class had people like John Baldeschwieler and others, it worked. I mean, it was a system where many classmates knew more than you did, and so they were helpful in teaching you, but no one knew radiation chemistry. There were very few places where it could be done, and the person who supervised—and I almost put that in quotes—my graduate research was Amos Newton, Amos S. Newton. As I got to know [Dr.] Amos Newton, I interviewed with him, I saw what he was doing, I also saw mass spectrometers at the nuclear chemistry building at the radiation lab, and talked to people who were doing that, but at the <T: 85 min> time I wasn't interested in mass spectrometry per se, and I thought, you know, radiation is going to be a big deal in this country, and radiation chemistry is going to be important. This is one of the few places where you can study it, and you can study it in all its forms, because there are gamma sources around, and there are proton accelerators, and there are electron accelerators, and there are alpha particle, that is, helium ion accelerators. You can do every flavor of radiation chemistry there is. And then there are all these instruments around, so you might have a chance to understand what you're doing. That was a pretty accurate analysis for a newcomer to that the field.

And so I signed up to work with Amos Newton. I learned later on that Amos worked for Eastman Kodak, and there were a number of industries at that point in time, all of which had major central research laboratories that had donated people during World War II to work in the Manhattan Project. And sometimes they continued to pay staff. As Argonne [National Laboratory] and the Radiation Lab at Berkeley and Brookhaven [National Laboratory] got under way, there were industrially paid staff that were there just to sort of track what's going on and participate in the research, and so on. A wonderful scheme. You know, I would recommend it again, if we ever had industries with large central research laboratories.

GRAYSON: I think that's a day that's gone.

FUTRELL: I'm afraid so, too, like so many twentieth-century things that disappeared. But it was an interesting fact. And later on...

GRAYSON: So, these people were being paid by the government?

FUTRELL: No, they were paid by their home companies.

GRAYSON: And they gave some of their time to...

FUTRELL: They gave all their time. They were 100 percent staff.

GRAYSON: Ah, okay.

FUTRELL: They were regular research staff, and they could actually help in teaching graduate students and could take on postdocs and everything else.

GRAYSON: Wow.

FUTRELL: Their funding was essentially independent of the Atomic Energy Commission, so it was an amazing phenomenon. So anyhow, once you [started in your research in radiation or nuclear chemistry], you learned that your work is cyclical, because you get time on these accelerators maybe every two or three months. And you spend all the time in between figuring out what you did, what you did wrong, and then...

GRAYSON: What you're going to do right next time.

FUTRELL: What you'll change and do right next time. And so I was—finally got some time to [analyze an irradiated solution] sample, and of course, Amos Newton was looking over my shoulder for everything that I did. But he went home for the weekends, and so I was there on the weekend, starting to work up my very first radiation experiment, and the door to my laboratory opens, and Ernest [O.] Lawrence walks in, Ernest Orlando Lawrence. And he says, "Hello, I'm Ernest Lawrence." And I said, "Yes, sir, I know who you are." He said, "Who are you?"

GRAYSON: I'm nobody.

FUTRELL: By this time, I knew I was nobody, so I didn't say, "I'm the smart kid from Dry Prong." [laughter] Or from Louisiana Tech. Or an NSF Fellow. I said, "Hello, I'm Jean Futrell." And he says, "What are you doing?" So he [spent] fifteen minutes or so with me listening to me, asking questions, and so on.

And that's a lesson learned that I've practiced my whole career, and it's been extremely helpful in a whole variety of ways. Maybe most recently, I think last year at a Pittsburgh Conference [on Analytical Chemistry and Applied Spectroscopy], I took my artist wife [Anne Graham] to see an exhibit. I picked out exhibits for their artistry, not for what was being sold or talked about. And there was a relatively small company, I don't remember the name or the person, but Anne was intrigued by the display, and asking how he created that, and so on and so on. So we had an in-depth conversation, and I was glancing at my watch ready to go to the next station stop, and in passing, after this engaged conversation between my artist wife and this company president, he noticed my name, and he said, "Oh, <T: 90 min> Dr. Futrell. You taught me at the University of Utah." And so we figured out when. It was my last semester before I moved to the University of Delaware. Because I had already submitted my resignation, they stuck me with the physical chemical laboratory. This guy was in the physical chemistry laboratory. And I had TAs who could do part of the work, but I had to do [a laboratory course for my final semester]. And it was either the first or second time I had ever taught P-chem lab, and so I really was interested in what they're doing. I knew some of the experiments [well] because I had convinced companies to donate surplus mass spectrometers.

GRAYSON: Oh, wow.

FUTRELL: I knew the mass spec experiments that they did. But I went around to talk to everybody and find out what they were doing and what they were learning and so on. And so this kid remembered me, and said that I actually stimulated his interest to continue in science. [...]

. [As a radiation chemist, not a nuclear chemist,] I met with [Seaborg] at least once a year.

GRAYSON: Okay. So he was a real hands-on guy? [laughter]

FUTRELL: Actually, in my first meeting with Seaborg after I signed on, [Glenn gave me excellent advice on pursuing a career in science.] He said, "Whatever you do, live close to an airport," [laughter] "because odds are, you'll be on a plane a fair amount of time."

GRAYSON: That's an interesting...

FUTRELL: Good advice.

GRAYSON: Important advice to the budding scientist. [laughter]

FUTRELL: So anyhow, first meeting with him after I signed on to work in something he wasn't too interested in was his research conference that occurred every Monday, and so with this conference, there would maybe typically be a longer talk by someone of the faculty members or permanent staff, and there'd be two short talks by graduate students about what they were doing. And the way that this was [arranged] by lottery. [laughter] That is, you were a first-year student, your name would be in the hat once. If you were a second-year student, two times. Third-year, three times.

GRAYSON: Oh, wow.

FUTRELL: Four, five, six. I don't know how far it went.

GRAYSON: Eventually you'd figure you'd better get out so you wouldn't be doing it. [laughter] There was a message there.

GRAYSON: Right. Interesting approach.

FUTRELL: And Seaborg would pull the names out of the hat just before going in.

GRAYSON: Uh-oh.

FUTRELL: Again, it was part of the Berkeley system. You had to be prepared with no notice to give a seminar talk.

GRAYSON: Oh, great.

FUTRELL: And then there'd be a second drawing of lots to see who was [to take notes and prepare a report for the boss]. So the [recording] secretary would be a graduate student who took

the best notes possible. [Afterwards he would visit the speakers to correct his notes] and figure out what they actually said. And then we'd get these typed up. And actually, there was [an actual secretary in Seaborg's office] who would do the final typing and put these in final form. I later learned Seaborg circulated these around the world to former students and so on. This was telling them in general what was going on. I guess I'd been working four or five months, [when my name was called the first time. Fortunately, I was the note taker, not a speaker. The note taker was announced first, then the speakers.] <T: 95 min> He came in the room and sat down. I was already walking up to the front of the room, because I knew I was going to be note taker. They let you know [and gave you] a yellow pad and two or three pens and pencils and so on, to be ready for it. So, Seaborg looked at his notes, and looking over me, [and through me,] towering over me, he said, "Is Futrell here?" [laughter] And I said, "Yes, sir." We got a laugh [and he always recognized me afterwards]. I was the note taker. [...]

So, my career was in radiation chemistry, my graduate studies. Amos Newton was extremely helpful. There were other people that I could talk to. I was extremely fortunate that Cheves [T.] Walling from Columbia University had just published his book on free radical reactions, and he was a visiting professor, [while I was struggling with interpreting my results].³

GRAYSON: There you go.

FUTRELL: ...at Berkeley. I knew about that because he'd given an evening seminar talk, and so I bought a copy of his book, and I went to see him, as I was a graduate student, to get some advice and learn a little bit about free radical chemistry, which turns out to be part of the story of radiation chemistry, of course. He was very useful, to have an expert like that. And certainly, the Berkeley campus and the Radiation Lab collectively was a tremendous resource, if you were willing to take the initiative and talk to people, understand it.

Amos Newton was very good at the things that he did, and he did some analytical mass spectrometry, was a member of ASTM E-14. He wasn't one to understand the details or work with mechanisms, or kinetics, or things like that. He had been in separations during his World War II experience at the Ames Laboratory. So anyhow, he was very good at techniques up to a point, and a photograph that I'm going to give you and suggest you include shows me as a first year graduate student doing things I learned from Amos S. Newton in terms of separations. And what I was doing was separating molecular fractions by volatility, okay? You change the bath gas and you evaporate things, and you condense them, and so on and so on. You understand the drill, no doubt.

GRAYSON: The hard way.

³ See Cheves Walling, interview by Leon Gortler at Mayflower Hotel, Washington, D.C., 12 September 1979 (Philadelphia: Chemical Heritage Foundation, Oral History Transcript # 0009).

FUTRELL: The hard way. Okay? And then you, eventually, you have a vial or a container of some kind that has a sample. It's probably a gas that's been frozen out as a liquid, and then it's a gas when you submit it for mass spectrometer analysis. And those days, on a 21-102 CEC mass spectrometer. The first year or so I get to pass this through a glass door, and I'd get this roll of photographic paper with peaks on it, and little dots. You would count up the peaks, and you would assign your mass numbers. [laughter] You would measure the peak heights...

GRAYSON: Do the multiplication for the different scales?

FUTRELL: Yes, that's right. And Seaborg was kind enough to buy me about a one-meter-long slide rule, so I could get an extra decimal place. [laughter] And that entitled me to a desk in the laboratory, because the hutch where graduate students were [didn't have the space to manipulate my slide rule].

GRAYSON: It wasn't long enough for your slide rule.

FUTRELL: ...for my slide rule. [laughter] So, I got promoted. [laughter] Or demoted.

GRAYSON: So, I guess, you had to leave the slide rule with the school, or do you...

FUTRELL: Yes, they kept it.

GRAYSON: Oh, that's too bad.

FUTRELL: Too bad.

GRAYSON: It was a meter long, huh?

FUTRELL: Yes.

GRAYSON: Oh, wow.

FUTRELL: It was something. Anyhow, as you know from that era, it represented such a chore to get the peak heights, <T: 100 min> and such an incredible chore to figure out what you had, that I was sure happy I hadn't gone into mass spectrometry. That'd be the last thing on earth I'd want to really tie my future to.

Gas chromatography had been invented... basically had been invented in Britain. The patents were there, and so it didn't exist [as an established analytical technique] in the United States at that point in time. [...] I did gas chromatography as a separation technique, and then my samples were then analyzed by mass spectrometry. So, they were GCMS in a very, very, very, very primitive state. So, for me to do gas chromatography, I started with bricks. They were actually called fire bricks.

GRAYSON: Fire brick.

FUTRELL: And a hammer. [laughter] And you crack them into pieces, and then you go to [...]

GRAYSON: Put them in a tumbler.

FUTRELL: ...put them in tumblers, and then you have these sieves. And you eventually...you're nodding your head yes, so I know you remember that era.

GRAYSON: [Yes].

FUTRELL: And so eventually you get these little pieces of fire brick that are fairly inert and then you coat them with a high molecular weight something that gives you some selectivity. And our selectivity was lousy. [...] Since I was trained as a chemical engineer, I understood theoretical plates at one time, and probably calculated what it was, and that sort of thing. So I used this primitive form [of gas chromatography] and I actually did a peculiar form of distillation [as separation techniques prior to analysis of fractions by mass spectrometry]. I don't think it was ever described in the literature, and I don't know [whether] it was ever practiced by anybody else, but there were actually tall distillation columns [at the Radiation Laboratory]. There was one four stories tall that Glenn Seaborg had built as a research associate after his PhD, working with Lawrence, to separate the isotopes—heavy isotopes—of water. Doing distillation to get heavy water was a serious challenge, and Seaborg did that as a research associate. And so, you know, the kind of packing materials, as a chemical engineer, I knew something about it. I built a column. I think it was over two meters in height, and we built it with a glass vacuum jacket around it, because [we] had very sophisticated glass blowers. But

this was such a challenge that it took four times, I think, to get it constructed, so it didn't self-destruct the first time that you put the hot liquids in it, because this thing would grow taller by about three centimeters from top to bottom.

GRAYSON: The expansion.

FUTRELL: The expansion that took place.

GRAYSON: Wow.

FUTRELL: We had expansion joints, but we didn't know how many were needed. It was silvered and so on. It was a beautiful thing to behold, and I'm sorry I didn't get a photograph of it. And it operated under total reflux, and so I just let it cook, and then I would open the top and take a sample for a brief period of time, and then I would close it again and operate it under total reflux conditions. Obviously, that's the limit. You know, we learn that in chemical engineering. The limit of resolution is you don't take anything off of your column, but it was my idea to operate it that way and use it to purify starting materials, so that's part of the story I set out for my radiation chemistry project, suggested by Amos Newton...

GRAYSON: So Seaborg wasn't really interested so much in...

FUTRELL: No.

GRAYSON: You just had a kind of titular connection with him?

FUTRELL: Sure. Titular connection. Had to take certain courses, including his. [laughter] And <T: 105 min> got to see him occasionally, got to meet his family, and so on. Later in life, developed a much closer relationship with him, and I'm quite sure we'll get to it, I was the last person to have a scientific conversation with Glenn Seaborg. Anyhow, I developed huge respect for him when I understood his career in totality. But [for a research director]...

GRAYSON: But, I mean, you knew even when you were beginning your graduate career, you knew his name had a certain...

FUTRELL: Sure.

GRAYSON: Well, I guess he had won the Nobel Prize [Chemistry, 1951].

FUTRELL: Yes, he had the Nobel Prize. He had the Nobel Prize, and he was Associate Director of the Radiation Laboratory, and, you know, countless responsibilities elsewhere.

[Returning to my thesis topic, I investigated the radiation chemistry of *cis*- and *trans*-1,2 dichloroethylenes.] So anyhow, the dichloroethylene—*cis*- and *trans*- dichloroethylenes—were notable exceptions to what was expected of unsaturated compounds, because they could not be polymerized [using typical free radical initiators]. Could you polymerize them with ionizing radiation? So, it doesn't work by ordinary means, okay? Well, let's use extraordinary means. Let's use ionizing radiation. Let's do it in all of its forms. We have to shoot heavy ions at them. We'll do it.

GRAYSON: And you had all the forms of ionizing radiation at your [disposal] there.

FUTRELL: [Yes]. We did. We did. Everything was at our disposal to do that. And so if ionizing radiation can do it, we will. Okay? And so we started doing this, and, you know, painful analysis of identifying the chemicals and finding out what was there, and then increase separation technology, which gave us more molecules to identify, and so on, and a very, very crude gas chromatographic tracer peaks. We eventually got to the point of doing our analysis, part of it, by gas chromatography, in a very crude, non-commercial way. But I finally got some pure starting compounds, because a lot of concern by people who talked about trace impurities and how they would affect radiation, because even at trace levels, very reactive molecules could totally change your chemistry. I went totally berserk in terms of trying to purify stuff with existing technology, and guess what happens when you get them extremely pure? Right. They polymerize.

GRAYSON: [Yes]. [laughter]

FUTRELL: And it doesn't require ionizing radiation. It requires a free radical. Now they don't make high polymers, but they make oligomers, and they just keep going on until they get so crowded in the number of chlorines that they're not interested anymore.

GRAYSON: Gets to be a...what's the term?

FUTRELL: Yes.

GRAYSON: Limited thing.

FUTRELL: It's a self-limiting kind of polymerization reaction. The whole theme I'd worked on was trashed. [laughter] But they let me graduate anyway.

GRAYSON: Well, I mean, you know, but you also discovered something that was...why it worked and why it didn't work.

FUTRELL: Sure. And I learned quite a few things [about science and about people. Many of these experiences were in the classroom or laboratories and in extracurricular activities of many kinds. A special category for me was my military connections.] <T: 110 min>

I went to Berkeley with an ROTC commission. I was expecting to go to active duty, despite having won the NSF Fellowship. But the Armed Services decided that anyone who had won certain extremely prestigious fellowships, Guggenheim [Fellowships], for example, and the NSF graduate fellowships, would be deferred for their graduate studies. And so, my military career was postponed till I completed my graduate training at Berkeley.

GRAYSON: Okay. Just to, kind of recompose some of this, you completed your summer camp training...

FUTRELL: Sure.

GRAYSON: ...so that you could fulfill your ROTC requirements.

FUTRELL: Yes. And I was commissioned.

GRAYSON: And so you're commissioned as a Reserve officer.

FUTRELL: Right.

GRAYSON: But you were able to defer your active duty to go to graduate school?

FUTRELL: Yes. I was second lieutenant in the United States Air Force Reserve, and I was stationed...I went to graduate school in Berkeley. [It turned out that] there were two Air Force Reserve squadrons in the United States.

GRAYSON: Oh, wow.

FUTRELL: One in Boston and one in Oakland [California], Bay Area.

GRAYSON: Okay, sure.

FUTRELL: Drawing on the Reserve officers who were in that vicinity. And so I was a member of the Reserve squadron, and I went to active duty somewhere every summer.

GRAYSON: Oh, wow.

FUTRELL: Okay?

GRAYSON: So, this was a time you had to take...what was it, six weeks?

FUTRELL: Two weeks.

GRAYSON: Two weeks.

FUTRELL: Two weeks. Two weeks. And I discovered that National Laboratories were suitable training grounds for a research officer, and so I had my first visit to Oak Ridge [National Laboratory] as a second lieutenant.

GRAYSON: There you go.

FUTRELL: So, I again knocked on doors and said, "Hello, I'm the kid from Dry Prong."

GRAYSON: Crawling up the ladder here. [laughter]

FUTRELL: I got to talk to real radiation chemists and other people that were extremely helpful. The grandfather of radiation chemistry was Samuel Colville Lind, S. C. Lind.

GRAYSON: Samuel Colville.

FUTRELL: Yes. Yes. And he was probably an emeritus scientist of some kind at Oak Ridge, and I got to meet him. He was totally deaf, and he had a huge amplifier. So, it was, sort of, a 14-inch microphone that you spoke into, and he wore headphones to have the conversation.

GRAYSON: Wow. My goodness.

FUTRELL: And so, it was not an extremely useful conversation to me scientifically, but it was a great honor to meet sort of the godfather of the field that I was getting into.

GRAYSON: So, this was after your graduate career was...

FUTRELL: No, no, no. This is during my graduate career.

GRAYSON: Oh, oh, okay.

FUTRELL: I was on my Reserve tour, where I visited Oak Ridge.

GRAYSON: Ah. Oh, okay. One of your two week tours was to Oak Ridge.

FUTRELL: Yes, a two week tour at Oak Ridge.

GRAYSON: Oh, that's a good deal.

FUTRELL: And I got to meet him and many other people. And as I said, he was totally deaf. That's part of the story. He certainly was in his seventies, I think. God, he was our age, Mike. No wonder he seemed so old. [laughter]

GRAYSON: We've got to erase this part of the <T: 115 min> conversation. [laughter]

FUTRELL: But a few years later, before I was really a practicing scientist, and could be in a different way, he actually was tragically drowned. Because the other thing he did was fishing in Oak Ridge, and they sound the sirens before they open the dams, okay...periodically, to dump water. And he was oblivious to that, and got washed away and drowned. But, you know, at 80-something, it's probably as good a way as any. Certainly spectacular. The other short tour that I had was to go to Edwards Air Force Base in California. I went, [on] a two weeks tour, Edwards Air Force Base, and I was assigned to the rocket test facility, not knowing up to that point that we had rockets. [laughter]

GRAYSON: This was probably late 1950s?

FUTRELL: No, this would have been 1956, I think.

GRAYSON: Oh, mid-fifties.

FUTRELL: Nineteen fifty-six or 1957. And it was in a concealed part of Edwards Air Force Base. It was 1957. I can pinpoint it precisely.

GRAYSON: Nineteen fifty-seven.

FUTRELL: Yes. Part of the story, I had just bought a new car, because the old car had been holding together all these years and was falling apart. And so, I spent the last of my cash and borrowed money to buy a 1957 Plymouth.

GRAYSON: Oh, wow.

FUTRELL: I drove it to my summer tour of duty and got caught in a sandstorm in the Mojave Desert that stripped the paint off of my one week old new car. [laughter] And pitted the glass.

GRAYSON: Oh, man.

FUTRELL: I took it back to the dealer, he said, “You’ve got to be kidding.” [laughter] “Why did you sandblast a brand new car, less than a month old?” I said, “It was an accident.”

GRAYSON: Oh, my goodness.

FUTRELL: Oh, gosh. But anyhow, back to the un-sandblasted car, new recruit on duty, round the curve, there are these Atlas rockets on the sides of the mountains.

GRAYSON: That you didn’t know anything about.

FUTRELL: And they’re learning how to shoot them. Anyhow, for two weeks I was a rocket scientist, okay?

GRAYSON: The real McCoy, huh? [laughter]

FUTRELL: Real McCoy. I did things that have never seen light of day. [laughter] I designed, you know...you may as well delete it—confess, we’ll delete it. I proposed a rocket. Let’s see, an ion powered rocket propulsion system, interplanetary space travel. [laughter] I wrote a report recommending that.

GRAYSON: Oh, wow. You were ahead of your time, weren’t you?

FUTRELL: The project they assigned me, first of several interesting Air Force projects, they wanted to...they weren’t sure you could restart a rocket in outer space.

GRAYSON: Well, [Yes]. That’s an interesting thought.

FUTRELL: Sure. And, you know, I had worked with bell jars and vacuum pumps.

GRAYSON: Sure. Vacuum systems.

FUTRELL: So they said, “Design a vacuum chamber big enough to...”

GRAYSON: Fire a rocket?

FUTRELL: “...restart a rocket and hold vacuum for a minute.”

GRAYSON: Uh-huh. Without it blowing a bell jar. [laughter]

FUTRELL: So I did some slide rule arithmetic on a small slide rule, and I said, “Well, you’re in Eastern California. If you take part of Nevada....” My official report recommended they try it in outer space. It’d be much cheaper to fire several rockets than it would be to complete my project. [laughter]

GRAYSON: Right. You had a large enough vacuum to take care of the...

FUTRELL: Sure. <T: 120 min> But I got to know some names, and Sputnik was launched.

GRAYSON: Oh, yes. The good old Sputnik.

FUTRELL: So, Sputnik was launched about that time.

GRAYSON: That made the rocket thing a lot more exciting.

FUTRELL: Yes. And the rocket science got a whole lot more interesting. And Sputnik came over California. We could see it in the mid-morning hours, sort of 2:00 or 3:00 in the morning. My father—my parents—visited. That was my graduating year, senior year. And I remember showing this to my father, spinning over, and it would twinkle as it went across the sky, and I described what it was and so on, and he said, “Nope, it’s a fake.” [laughter] There was a movie made to that effect later on. But my father, who refused to fly...he allowed my mother to fly, and he couldn’t stop me from flying. He tried. He says, “Nope, things that go up come down.” [laughter] “This will never work.”

GRAYSON: Basic science, right?

FUTRELL: Absolutely. I could never convince him otherwise. That was one of several interesting conversations we had, confrontations between science and practical common sense. Whatever.

Anyhow, Sputnik changed everything. For my final tour of active duty, we actually organized a course that was taught...it was initially going to be taught at the University, and it was sponsored by our Air Force squadron initially, but it got bigger. It involved NASA [National Aeronautics and Space Administration] as well, because we had already...we had conceived this idea earlier on, and we decided we would have a course in rocketry, and everyone would take our two-week course. But Sputnik had happened, and so it turned out that the aerospace industry in California bused their people in, and so our teachers included Wernher von Braun and others.

GRAYSON: Oh, wow.

FUTRELL: So all the big shots in rocketry came to teach our course that I took for credit for my Reserve officers' third tour of duty.

GRAYSON: You were organizing and...

FUTRELL: Yes. And so instead of the two weeks sort of concentrated course, it was one that was a series of two-hour lectures, or maybe three-hour lectures, that were taught in the Shrine Auditorium in [San Francisco] that was big enough that the busloads of people that were brought in for these lectures could attend. And those of us who started it got to attend. And living in Berkeley, I could get there early enough to get a seat fairly close to the front and so on.

GRAYSON: So that was kind of a crash course on getting...

FUTRELL: [Yes], it was a crash course.

GRAYSON: ...people in all types of industries up to speed.

FUTRELL: Sure. Sure. Sure. Exactly. Anyhow, I sort of learned a number of things that I would not have learned as an ordinary graduate student. Graduation day, I had interviewed

various places. Some of them scared me away. [...] I interviewed several academic possibilities at that point in time, but I didn't think it was something to take seriously, because I knew my military service was imminent.

GRAYSON: Yes. Sooner or later you were going to have to pay the piper.

FUTRELL: Have to pay the piper. And so, I had done a couple of things. One is I'd of course talked to Seaborg about my issues and he arranged for me to meet a former [...] graduate student, [Elwood M.] Douthett. [...] And Woody was in charge of a classified project [whose] objective was to understand what the Russians are doing. So, it involved taking samples and doing chemical analysis.

GRAYSON: What kind of samples? Air?

FUTRELL: Well, I never quite got that far to understand what the samples were and exactly how they were acquired. But it was a very fancy lab in Sacramento, [California] <T: 125 min> somewhere.

GRAYSON: Somewhere.

FUTRELL: Somewhere. And so, with this contact, I talked to Woody—sometimes known as General Douthett, he was to me at that time—and I thought the notion of, you know, spending time in California [was a very good idea].

GRAYSON: [Yes].

FUTRELL: One of my other job interviews, [obviously], because it's the one I took to go to Baytown, Texas. But the other one, I interviewed at Shell Laboratories, because ion molecule reactions had been discovered by [Victor] Tal'rose in the Soviet Union [Union of Soviet Socialist Republics], and—and [independently by three] scientists at the laboratory. Shell Development [Laboratory] in Emeryville, California [...] had [made] huge discoveries, important discoveries in ion molecule reactions that was brand new news the year that I graduated. It was D. P. Stevenson, [J.W.] Otvos [...]—I don't remember his first name. [...] And D.O. Schissler, Stevenson, Otvos, were the three co-authors on sort of three or four of the first dozen papers published on ion molecule reactions measuring cross-sections and making the statement they occurred at every collision. So, that was big news.

GRAYSON: And this was all being done in an industrial research territory?

FUTRELL: [Yes]. Sure. Where they had mass spectrometers, okay? And this is kind of basic science.

GRAYSON: Oh, [yes]. Very basic science. [...] Do you have any idea how Shell rationalized this? Or was it just...

FUTRELL: It was a basic science laboratory in Emeryville, California. And I would have signed on in a minute, you know, to stay in the same spot and work with these guys, but there were no slots, you know. They knew how many people they were going to fund, and that's all they were going to fund, [in] gas phase [ion] chemistry [...]. And so, they kindly sent me to one of the refineries in Southern California, and I politely declined the chance to work there.

GRAYSON: Well, I mean, you had a BS degree in electro or chemical engineering.

FUTRELL: [Yes], I could have done it. I could have done it.

GRAYSON: So, what the heck, you know?

FUTRELL: Sure. I know I could have done it. But I was more intrigued by...and then the others were Franklin, [Frank H.] Field, and [Frederick W.] Lampe were publishing their papers on ion molecule chemistry.⁴

GRAYSON: Once again, industrial...

⁴ F. H. Field, J. L. Franklin, and F. W. Lampe. "Reactions of gaseous ions. I. Methane and ethylene." *Journal of the American Chemical Society* 79, no. 10 (1957): 2419-2429.; F. W. Lampe, J. L. Franklin, and F. H. Field. "Cross sections for ionization by electrons," *Journal of the American Chemical Society* 79, no. 23 (1957): 6129-6132; Lampe, F. W., F. H. Field, and J. L. Franklin. "Reactions of gaseous ions. IV. Water." *Journal of the American Chemical Society* 79, no. 23 (1957): 6132-6135. Also, see Frank H. Field, interview by Michael A. Grayson in Durham, North Carolina, 9-10 December 2009 (Philadelphia: Chemical Heritage Foundation, Oral History Transcript #0636).

FUTRELL: Once again, industrial. And then the other part of the picture is that the University of Utah, Henry Eyring, Austin [L.] Wahrhaftig. [...] Austin Wahrhaftig, and Henry Rosenstock, graduate student. M. [Merrill] B. Wallenstein, W-A-L-L-E-N-S-T-E-I-N, Wallenstein. Had just published a seminal paper based on Henry Eyring having been invited to give a talk at Princeton [University], having met with some people there who did mass spectrometry, and thinking about mass spectrometry on this flight back, decided to tackle it with absolute rate theory.⁵ So, absolute rate theory of mass spectrometry was being hatched in real time as I was finishing up my PhD in radiation chemistry. I had several interview trips. I got to do my first commercial airplane flying all over the country. That was fun. Do you remember when airplane travel was fun?

GRAYSON: Right. I remember.

FUTRELL: Way back.

GRAYSON: Way back. People dressed up.

FUTRELL: [Yes], people dressed up. They wore ties. You got served a two or three course meal.

GRAYSON: [Yes]. You had a seat with enough space to, you know...

FUTRELL: [Yes], that reclined. Had propellers. [laughter] You could have confidence.

GRAYSON: Oh, yes.

FUTRELL: <T: 130 min> [...] Well, anyhow, I got lots of interviews, and...

GRAYSON: Did you interview DuPont? That's what... [laughter]

⁵ Henry M. Rosenstock, M. B. Wallenstein, A. L. Wahrhaftig, and Henry Eyring. "Absolute rate theory for isolated systems and the mass spectra of polyatomic molecules," *Proceedings of the National Academy of Sciences of the United States of America* 38, no. 8 (1952): 667.

FUTRELL: No, no. I'd forgotten all about that.

GRAYSON: Did you forget about DuPont?

FUTRELL: That was not on my list anymore. Completely scrubbed from my list.

GRAYSON: But you had discounted academic positions at that time.

FUTRELL: [Yes], I discounted academic positions. I did look at a couple. [Because of my impending military duty I] decided to not think about that seriously. The one that scared me was Bell Laboratories because Bell, as you know, was the world-leading industrial fundamental science laboratory in that time, back when Bell System was a monopoly, so part of our telephone bills paid for this fundamental science laboratory. Bell Laboratories had picked up on what I concluded three years earlier, that radiation was going to be an important part of the future. And they talked to Seaborg and decided that they would like to do radiation chemistry. And so, he had a kid that knew something about it. [...] He gave them a sales pitch. And so, I got my trip to New York City [New York], see the big city lights and so on. This is the kid from Dry Prong.

GRAYSON: Right.

FUTRELL: Okay? So big city lights. Flew into [and] stayed in New York, saw Bell Laboratories downtown, and then went to their main laboratory facility. Scared me to death to see all the things that people were doing. I shouldn't say scared me to death. It really excited me, okay? I was just completely bowled over, you know. I thought Berkeley was the center of the universe, and there'd be no laboratory that could possibly compete with that. But they had explained to me they weren't going to hire me. They sort of don't hire their own until they get a Nobel Prize, and they consider them seriously. [laughter] But anyhow, I was just completely astounded by the kinds of things...and also the practical stuff they did, you know, because it went entire gamut of possibility. Very applied stuff having to do with cables under the ocean, things like this. And amplifiers and all sorts of stuff. But lots and lots of laboratories where people had built up unique experiments.

And so, the shocking thing is I got an offer, and the offer was huge. I could have set up my own laboratory. They were going to give me sort of a starting fund that was large enough that I could hire three postdocs and three technicians to work with me. And, you know, one million dollars start, and then more if it was needed to get a laboratory set up. Do an inflation correction, you know, that's more like fifteen million dollars nowadays. It's in the same ballpark as my current research grant. So anyhow, I said, "What'll I do?" And nobody had any

suggestions. I could do anything that I wanted, okay? Anything that I wanted. So, I said, “Well, let me see. I want a couple of mass spectrometers, I guess, and somebody to run them.” I talked to Amos, I talked to other people, and I just couldn’t come up with a research program. They didn’t even ask me. You know, just come in and start one. And unimaginable, someone to offer you a job without you having to do a candidate seminar and sort of talk about what you were going to do. And so, I turned them down, and I used the excuse of the ROTC. It wasn’t an excuse. It was a reality. But I said, “You know, it’s not fair to you or anybody else and so I’ll pass it by.” But really, you know, I just didn’t have the self-confidence at that point in time. Now I know I could do it, okay?

GRAYSON: Offer it to me again.

FUTRELL: [Yes]. [laughter] You can work with me.

GRAYSON: Hit replay. <T: 135 min>

FUTRELL: Let’s replay this, start over again. So anyhow, Franklin, Field, and Lampe seemed like the very best thing one could possibly do. I had been there before for the summer. I had a great deal of fun working so close to the Gulf of Mexico. I had forgotten the heat and humidity of the South. [laughter] I accepted the job. The first time, the move was paid for. I didn’t have much to move. Moved it to Baytown, Texas. Baytown, Texas, paid for a real one-bedroom apartment. You know, it was air conditioned, had a swimming pool, real luxury. I reported for duty, sort of got my indoctrination to what it meant to work in an industrial research laboratory, had the tour of the refinery that joined the central research lab. I still remember that paraxylene is green, you know. We went around...because they gave us a quiz, what does this do, that do? The paraxylene unit was green. The cat [catalytic] cracker was big. [laughter]

GRAYSON: Well, [Yes]. Show them you’re a chemical engineer, right? [laughter]

FUTRELL: I’ve long since decided I wasn’t a chemical engineer anymore. And I learned the bad news that I was not going to work with Franklin, Field, and Lampe. I was going to do radiation chemistry. But that wasn’t bad news, you know. That was okay. And then my mail was forwarded, so something like my fifth day at work I carried in my active duty orders sending me to Sacramento. They were assuming that I was going to move from Berkeley to Sacramento. But that wasn’t the case. And so I, you know, came in sheepishly and said, “Well, I warned you. Here it is. And so I’m really sorry.” I had looked forward to spending some time...we all knew it was a matter of months, but I didn’t think it’d be a matter of days. And they said, “Well, you know, this is really unfortunate. Will you mind if we talk to our [U.S.]

Congressional liaison?” And I shrugged my shoulders, you know. I’m doing it now. I shrugged my shoulders. “Sure.”

GRAYSON: Do what you can.

FUTRELL: [Yes]. Whatever. Not having the faintest clue what that meant. Well, Lyndon Baines Johnson was their Congressional liaison person.

GRAYSON: Oh, oh. Well, sure. Okay. Texas, Baytown.

FUTRELL: I mean, not direct, but...it was some reason that Lady Bird [Claudia Alta Taylor Johnson] owned all the land south of us, where NASA was building their big research center. So, I got a deferment, and so I didn’t get to go back to Sacramento after all. So, I got to spend some time [at the Baytown Research Center]. And I never did a postdoc for this reason, and postdocs were not sort of normal that everyone did those. They were getting to be common for academic careers, but there were so many industrial labs, like Bell Labs, DuPont Central Research [Department, where] you could do the kind of research that postdocs do now and then go academic. [...] They really were doing a lot of fundamental research at that time. And the Baytown lab was a very good one, I think, that I happened to land in.

And so, I was not allowed to do mass spectrometry or get involved with ion molecule reactions, but I did have coffee break twice a day and each lunch quite often with Frank Field and Fred Lampe...Joe Franklin less frequently, but I got invited to his lawn parties, and among other things, he taught me how to drink Scotch whiskey with no dilution, and good Scotch whiskey [at that].

So there are many things I learned from Joe Franklin—I have a long list of things. [My point is] I got to know him, and I appreciate him for all the years that he lived. I was part of the Franklin, Field, and Lampe coffee club, so to speak, and I learned a lot. It was the equivalent <T: 140 min> of the best kind of postdoc that one could imagine. But I was a radiation chemist, and they were also calling on my chemical engineering [skills] in [ways] that I didn’t [fully appreciate]. [Mainly,] they wanted me to do radiation chemistry. They had an electron accelerator there, high energy electron accelerator.

GRAYSON: This was at Humble?

FUTRELL: Yes. And Fred Lampe had been doing that [until] he switched over to doing the ion molecule chemistry, and photochemistry, and other more fundamental molecular science kinds of things. So, they had a set of people who were doing it there, and they had other reactors

in New Jersey. The central research part of Exxon—I guess it was still Esso [Standard Oil Company of New Jersey], maybe, had just become Exxon. That was the timeframe when this was happening. They were calling the shots in New Jersey, and more or less in what happened where. But they had built a pilot plant, and they were getting very serious about radiation processing, and so they had serious chemical engineers and others working on radiation processing of hydrocarbons into chemicals. That was the general plan that they had.

GRAYSON: So this would be, like, an activation, a radiation activated chemistry type thing?

FUTRELL: Yes. That's right. And I didn't know very much about that, but I started reading the reports that they had done, [mainly] laboratory studies, including some that had been done at Baytown, and I knew enough about radiation chemistry, I said, "Hold on. Wait a minute. There's a problem here. It doesn't really make sense." And so, they were getting turnover rates or radiation chemistry yields, G factor was the term applied to it. That was a yield of chemicals [expressed as molecules generated or consumed] per hundred electron volts [energy] dissipated in your system. And so I said, after reading all the reports and looking at some of the experiments, I said, "You've got a real problem. I do not believe that you're doing your dosimetry correctly. And so, your calculation of radiation dose based on what I know is off by one to two orders of magnitude."

GRAYSON: Not a little bit but a huge bit.

FUTRELL: A lot. A huge [amount]. And they said, "Are you sure?" And I said, "No, I'm not sure. I certainly don't know. But we'd better go back to square one and get recalibrated on all of this stuff." And so I did radiation chemistry, and I used some of the things I'd learned at Berkeley. By now, gas chromatography existed. You could buy one. I think they were Varian Aerographs or something like that.

GRAYSON: [Yes], Varian Aerograph was one.

FUTRELL: It was getting to the point you could do things a lot easier, a lot faster, and so on. And so I showed them by about three or—at least three different sets of measurements that they were wrong, and then I went back and figured out what they had done incorrectly. They were actually measuring ion currents in their dosimetry, and [...] they didn't realize you could initiate a discharge, depending on the voltage. And so if you're—have [high energy electrons] striking an electrode, you can get a discharge started, and so you're getting secondary ions and secondary free radicals and so on. They managed to restrike this successively at two or three different installations where they had studied [radiation effects on hydrocarbons]. And so, I thought I'd be a hero.

GRAYSON: Right.

FUTRELL: Well, no. [laughter] People who've invested money in a project are unhappy this kid from Dry Prong is showing them up. [laughter] But anyhow, in the—in sort of closing hours or closing days of my time at Baytown, I go to the discarded mass spectrometer that they had done all the early work on ion molecule reactions with, and <T: 145 min> so I actually did a few [studies] that other people had done already, and so I confirmed with my own hands in the last few weeks before going to active duty sort of the simple experimental techniques [for investigating] ion molecule reactions. But in the meantime, I'd watched Frank Field doing experiments with what he called the [Humble] Chemical Physics Mass Spectrometer. He and his technician ran these incredibly long strip charts, and they rolled them out on the floor. And then he would start on one end, and his technician from the other end, and they'd look for kinks. Those were appearance energies for ion molecule reactions that Frank used to work out mechanisms of ion reactions. So even then, I said, "Frank, that's crazy. You can't do that. You can't expect that you're doing this right." [For the most part, he actually got the right answer, confirmed later by tandem mass spectrometry.] But anyhow, it was great fun to be part of that group and to talk to them and learn from them and so on. And I also talked to people who did photochemistry and all kinds of other interesting experiments. I learned things from Exxon consultants, because they had big names on the payroll. So, these consultants would come, you know, as part of their retainer, they would visit the various—various laboratories. Edward Teller was one. He had been one of my professors at Berkeley.

GRAYSON: What was he like?

FUTRELL: Oh, he was fun. Once you got past his accent, it was fun to talk to him.

GRAYSON: Because he was kind of a bit of...I don't know what you call it. Kind of a...

FUTRELL: Maverick.

GRAYSON: [Yes]. Maverick I guess is a good word.

FUTRELL: Maverick. Yes.

GRAYSON: In the nuclear physics community.

FUTRELL: Yes. So, let me take a bathroom break, and I'll come back to some of the consultants.

GRAYSON: All right.

[recording paused]

GRAYSON: It says that we're recording. So, I want to pick up on a couple of things that you'd mentioned, your first interaction with Seaborg on getting some direction from him. I got the impression that there was something about that that you were going to tell me, but it may not make it on the... and I don't know if we ever got that.

FUTRELL: Oh. Is it the one where I said I was sure I had the last conversation?

GRAYSON: No, it was where you had first started to interact with him, and there were some things about that interaction that you thought might not want to end up in the final transcript, but you told him about this business with his conference that he had, when, you know, he just pulled the names out of the hat.

FUTRELL: Yes.

GRAYSON: But I thought there was maybe something else that you had wanted to...

FUTRELL: Well, it was a very large operation, and very structured operation that he had. And so in essence, other professors and sometimes staff members, so in my case, for example, Amos Newton is a name that I cited as the person who really directed my research, taught me the techniques of actually carrying out the radiation experiments and the starting point for the analytical separations and so on. And he helped me very much in the mass spectrometry, analytical mass spectrometry, part of the story. Someone else ran the mass spectra, but Amos is the one who showed me how to convert the photographic records, photographic traces, into mass spectral tables, and mass number, and intensity, and got me started on the mathematics of matrix inversion to get the compositions. So, it was a very painful and time-consuming process.

And then there was another person, faculty member, David [H.] Templeton [...] who actually signed off on the content of my thesis; the whole process was delegated. The part that

<T: 150 min> Seaborg was personally interested in was the synthesis of new elements, and he had two or three people who worked with him, Albert Ghiorso [...].⁶ So, Albert Ghiorso was a bachelor's degree engineer, and I think it was mechanical engineering. I'm not sure. He started to work with Seaborg just as World War II was breaking out, went with him to [University of] Chicago, came back to the Radiation Lab as it was being established after World War II, and so in essence became Seaborg's right hand man for the synthesis of new elements.

I had met him while I was there, and didn't get to know him very well. But we did notice, those of us who wore film badges and occasionally got posted at the top of the list for overexposure...in my case, it was always during the week that I had time to do ion exposure, and so [...] the periodicity was easily correlated with access to an accelerator. But Ghiorso was always close to the top, and so he was way overexposed, according to the standard guidelines, and yet he lived to be ninety-five, I think, when he died. He died just in the last year or two.

GRAYSON: Wow.

FUTRELL: I remember seeing his death notice description in *Chemical & Engineering News*, and so I checked it out and got a copy of the biography and so on, and learned a little bit more about him.⁷ It turns out, his background was similar to mine in many respects. He had a father who had only gone to grade school. He could only go to Berkeley because he lived in that town and worked odd jobs to get the tuition, modest though it was, and just kind of fell into this opportunity, had a skill set that turned out to be very useful, and was a self-taught scientist. He never bothered to get the credential of a PhD degree. And I've used his example many times since then that you don't have to have a union card to be a good scientist or a good engineer. You have to have intelligence and curiosity and stubbornness and other things, some good, some bad, to be a successful scientist.

So anyhow, I don't remember what else I was planning to say about Glenn, except that in the special courses that he taught in nuclear chemistry, he was seldom there. He was on the plane to Washington, D.C. a lot of the time. We noticed that he always skipped out when we were talking about the more challenging theoretical parts of his own topic. Some of us thought that was a little suspicious.

GRAYSON: Yeah.

FUTRELL: Not me, of course.

⁶ Darleane C. Hoffman., Albert Ghiorso, and Glenn Theodore Seaborg. *The Transuranium People: The Inside Story*. (London: Imperial College Press, 2000).

⁷ Susan J. Ainsworth, "Albert Ghiorso," ACS News, Obituaries, *Chemical & Engineering News* 89, January 24, 2011.

GRAYSON: So, you would have other people come in and teach those sections?

FUTRELL: Yes. Yes. He had guest speakers come in and talk to us about those parts of the course, and so on. Later on, I got to know him as a scientist. I found out that he knew much more about what I had done than I thought he did. I met him a couple of times in connection with the CHOC, Center for the History of Chemistry, predecessor to CHF. He was there being recognized and rewarded, and I got [to join] him at dinner at a very famous club in Philadelphia [Pennsylvania]. They had more portraits of Yankee generals than I ever expected to see in my life. [laughter] And professionally, at National Academy [sponsored events] and other places, I crisscrossed with him.

So, I think when we stopped before, I had just mentioned that I got to see a number of consultants that were paid an honorarium, retainer, to come talk at the various laboratories, and the Baytown lab was, sort of, a...what should I say? A <T: 155 min> country offshoot of the main Exxon laboratories in New Jersey. But we got to see several people, and Peter [J.W.] Debye was one that really caught my attention. They were a little bit challenged, I guess, finding people who were able to talk to Peter Debye and have a second opportunity. There were a few interesting things I learned, incidentally, by meeting Peter Debye. One was that he preferred to take the small train, which was kind of a Toonerville Trolley, from Houston [Texas] to Baytown, Texas, and so he would spend maybe an hour and a half of his day coming in, another hour and a half commuting back to Houston. That minimized the amount of time that he had to talk to people. [laughter]

GRAYSON: At Baytown?

FUTRELL: And one of his closest friends was actually the black janitor that helped to clean my office. And because Peter Debye talked to him and spoke about him, I got interested in talking to him myself. He had collected the *Great Books [of the Western World]* series, and so [he and Debye] actually talked about some of the great books in literature.⁸

GRAYSON: So this is Peter Debye and the janitor?

FUTRELL: [Yes].

⁸ Robert Maynard Hutchins, *Great Books of the Western World*. (Chicago: Encyclopædia Britannica, 1955).

GRAYSON: Oh, wow.

FUTRELL: Peter Debye and the janitor, okay? [laughter]

FUTRELL: And that [...] created a conversation opportunity for me with the janitor, and I bought the *Great Books*, and so on. I think they're over there behind us in the library. But Peter Debye was interesting to talk to. He had the fine opening questions, what are you doing, and I told him, and—and he immediately jumped on my side in terms of dosimetry and radiation chemistry, even though he didn't really claim to know anything about radiation chemistry, just some elementary physics of energy conservation and so on. Somehow, I don't remember how it happened, but I learned about image forces from him. Do you know what those are?

GRAYSON: It sounds like ion optics.

FUTRELL: Ah, it has something to do with ion optics. And we got into this conversation by talking about measuring ion currents, and so that was an offshoot of the dosimetry discussion, but how do mass spectrometers measure currents? Well, they [used] Faraday cups. They're Faraday cups because Michael Faraday came up with the basic design. And so, charged particles come in and then electrons come up and neutralize them, and you measure the—the electron current. One of the questions that we talked about is why don't the charged particles bounce off the surface? That ties into the end of my interview, because I started bouncing things off of surfaces, and sure enough, they do. Particular surfaces, they bounce quite well, but not for good electrical conductors. What happens as a charged particle, let's say a positive ion, approaches a conductor...the conductor is a sea of electrons. It's the Fermi Sea, not that that's particularly relevant. But what the charge sees in the Fermi sea—that's spelled differently, of course, S-E-E-S and S-E-A—in the Fermi Sea is that the positive charge sees a negative hole the same distance inside the conductor as the ion is away from the surface. And so, [...] Coulomb's Law pulls these two together, and then they annihilate on the surface. That's how this electron gets sucked up the wire, and an amplifier can detect the signal.

So, that's what the conversation was all about way back when I was just a tadpole in science, but it actually appears again in what I'm doing at this very moment, because...I'll describe briefly that I'm working on the very high resolution mass spectrometer that's based on a very intense magnetic field that will work with very highly charged ions, maybe more than one hundred charges per ion. And if you have one hundred positive <T: 160 min> charges coming anywhere near a conductor, then the image force, the mirror image of negative charges pulling on that ion exerts a drag force [that] pulls the ion out of its coherent motion and degrades mass resolution. And so, I find myself at the end of my career...

GRAYSON: Back at the beginning.

FUTRELL: ...exactly. Right back at the beginning, using some of the things I learned from one of the real pioneers in physics, Peter Debye.

GRAYSON: So, this Debye is a physicist. Why is...

FUTRELL: Yes.

GRAYSON: ...he going to talk to a bunch of petroleum chemists?

FUTRELL: I don't know. [I'm sure they paid him well and] I guess it looked good on their balance sheet or their report to stockholders, of having all these people...

GRAYSON: This is characteristic of an era in business in the United States...

FUTRELL: Sure.

GRAYSON: ...where there was this—I don't know what it was, just, kind of, an assumption—that if you brought people—scientific experts— into your organization and let them interact with your people, that this was a good thing.

FUTRELL: Yes.

GRAYSON: But, you know, they didn't have someone sitting there in the accounting office saying, "Well, let's see. We cost, you know, three hundred and fifty dollars for this guy to come in and I don't think we got three hundred and fifty dollars' worth of..."

FUTRELL: Exactly. That's right.

GRAYSON: "...stuff produced by the people he talked to."

FUTRELL: That's right.

GRAYSON: There wasn't that guy that was there trying to make the bottom line work out, and so they just keep doing this until this guy came along and said, "Your bottom line's bad."

FUTRELL: That's right. That's right. It's the business accounting and the tying everything to profit. And short term profit, because, I think...well, all of us would argue, and I think you could make a fairly strong argument, that this investment...I mean, my gosh. How long has it taken me to make use of this fact? It's taken over fifty years for me to make use of a fact that I learned through this coincidence of a high-powered scientist coming by as a consultant. But in the aggregate, I think it's probably more like a decade, where the real benefit from those kinds of visits [show up in the bottom line of a business.]

GRAYSON: So, Debye was coming from Houston?

FUTRELL: Yes. He would fly into Houston, and...

GRAYSON: Oh, so he'd fly into Houston...

FUTRELL: Fly into Houston and then take...

GRAYSON: Where was he at the time? Is he up on the East Coast?

FUTRELL: [Yes], he was East Coast. I've forgotten where he was.

GRAYSON: Princeton [University], Harvard [University], Yale [University], some of those...

FUTRELL: Probably Ivy League, I'm sure Ivy League school [Cornell University]. And then there were other people coming from everywhere, from Yale, and Harvard, Princeton, so on, and there would be a seminar talk, and I learned some things about things I absolutely didn't know. And a few of them turned out to be useful much sooner. So, I thought it was a good thing.

GRAYSON: But now how long were you at Humble?

FUTRELL: Oh, I was there for eight months.

GRAYSON: Okay. So, you were able to get this special deferment type thing that you didn't have to go to Sacramento, and so you could stay there for a little bit longer.

FUTRELL: Yes, that's right. That's right. And then my orders came, and the orders were to go to Wright-Patterson Air Force Base, not to Sacramento. And I didn't think it was worth another conversation with their Congressional liaison at that point in time. I thought my number was up.

GRAYSON: So you'd signed up probably by this time like ten or twelve years earlier for this duty.

FUTRELL: Sure. [Seven years.] And it was my obligation, and certainly I was going to do it, but I did call General Douthett to ask why I wasn't being assigned to him, and I learned, first of all, he'd been reassigned somewhere else, but he inquired, and we found out that in the Pentagon they had this requisition for my services that matched up my skill set to what was needed, but they had an even more important project at Wright-Patterson that fit my qualifications so perfectly that this was a trump card, and so they were going to assign me to Wright-Patterson. It was a high level decision in the Pentagon. And so I packed up my goods and moved to Ohio. And in Ohio, after I reported for active duty, I discovered that between sending out my orders and my reporting for duty, they had filled that <T: 165 min> position.

GRAYSON: Oh, jeez. [laughter]

FUTRELL: So I was up for grabs.

GRAYSON: Amazing.

FUTRELL: Yes. So, interesting times. But I sort of knew by this time [how to manage the situation]. I knew Joe Franklin [well], so I called Joe and asked for help, and of course he knew people who knew other people who knew people in the Air Force. And it turns out there was a brand new laboratory at [Wright-Patterson Air Force Base], meaning it had opened less than a year sooner, called the Aerospace Research Laboratory. And it was a blue sky fundamental science laboratory that was set up after years of planning and argument. Theodore von Kármán, another very famous physics person, had the quotation on the glass door as you went in the building of the Aerospace Research Labs. A quotation of von Kármán, in which he said the Air Force, being the most high-technology [branch] of the Armed Services, being involved in

aerospace as well as military aircraft and weapons systems and other advanced technologies, had the greatest need of any of the Armed Services for a fundamental science laboratory, staffed with the highest level, highest quality of scientists and engineers that could be hired. So that was their motto, and I said, “Hey, that sounds pretty good.”

I wasn't as afraid as I'd been earlier in my career. I was ready to do this. So, with this information and phone calls, I had an after-hours interview prior to my formal interview, and got to talk to people in the chemistry division at the Aerospace Research Labs. And then I did the other required interviews with other parts of Wright-Patterson. I played the game, in other words. [...] Amazingly enough, Aerospace Research Labs had a job that met my qualifications perfectly. Amazingly enough, they assigned me somewhere else. [laughter] At which time I balked, and I [asked] to assert my legal rights. By the way, I was a first lieutenant, because I had served the country well in these three two-week tours of duty [while I was in graduate school]. I had good ratings, and I had been promoted to a first lieutenant, and so I felt that I could speak to the captain who was giving me my orders, and I said, “No. The assignment that you've offered me is not something I can do. It's not something anybody can do. It is really a violation of physical laws to produce what you're asking that person to do. I'm not going to do it. How do I get out of it?” [laughter]

GRAYSON: You're always trying to get out of it.

FUTRELL: Well, [everyone is] confronted with challenges continually. I was read my rights, so to speak, and you are entitled to legal counsel. The Judge Advocate General's office is separate from the line of command, and so I could, if I wished, speak to someone from that [branch of the Air Force]. But then they compromised. They said, “All right, we'll give you the assignment you want, and we'll put this letter into your personnel file saying that you are not recommended for military service beyond your [present] tour of duty.” [laughter]

GRAYSON: For which you were...

FUTRELL: Which was okay with me. [...] Now later in my career I got an Air Force commendation medal which cancelled that out, but I still elected not to extend my tour of active duty. [laughter]

So that's how I got into the Aerospace Research Laboratories. I worked with a French-Canadian, now U.S. citizen. His name was Jean [-Marie] Dubois. He spelled his name the same as I, except <T: 170 min> being French-Canadian, he pronounced his name Jean, the correct pronunciation for my name, from my historical ancestors. J-E-A-N and D-U-B-O-I-S, Jean Dubois [...] was a photochemist, and that pretty much matched up with things I was interested in doing. He was a wonderful person to work with. He gave me the freedom to include exploring radiation chemistry.

In the meantime, while I was still at Baytown, I had written a single-author paper.⁹ I believe it was my first publication preceding my thesis, in which I did a theoretical prediction of the radiation chemistry of normal-hexane, a hydrocarbon, that matched up within plus or minus 10 percent of the exact distribution of products that had been observed experimentally. And I did this using mass spectroscopy; that is, taking the cracking pattern, the mass spectrum, as a pattern of ions that you start with, [assuming these ions immediately react with hexane by known] ion molecule reactions [...] ion molecule reaction chemistry. And then based on conversations primarily with Fred Lampe and with some free radical chemists, made some guesses about ion neutralization and the pattern of free radicals that you would expect. And they were intelligent guesses. And putting all this stuff together, hit the jackpot; that is, came out very close to the experimental values. And so, all of a sudden I started getting invitations to speak to people, give presentations—universities and other places—and got more degrees of freedom to actually do gas phase radiation chemistry, where I was sure that you'd be a whole lot closer to mass spectrometry.

I [shortly afterwards] made contact with Austin Wahrhaftig and his colleagues at the University of Utah, and used the absolute rate theory to calculate the time dependence of a mass spectrum. And what I was doing then was extrapolating back in time to about ten to the minus ten seconds, because that's the collision frequency, roughly speaking, [for ions with typical gases] at atmospheric pressure. And so, my [idea was] you could take the measured mass spectrum, apply the absolute rate theory, change the time by a mere four orders of magnitude, then you'd have the right distribution for radiation chemistry.

GRAYSON: Wow.

FUTRELL: Okay? Well, it's, kind of, a leap.

GRAYSON: Just a few orders of magnitude in there.

FUTRELL: And [working with Jean Dubois], I started studying free radical chemistry, using flash photolysis. I got involved with [George] Porter from England who had done flash photolysis, and who was someone who was—George Porter, Sir George Porter. And someone that Keith [R.] Jennings knew, another name that crops up in my biography.¹⁰ But I was reading his papers, and started building giant capacitor banks and flash tubes to do flash photolysis.

⁹ J. H. Futrell "High Energy Electron Irradiation of n-Hexane." *Journal of the American Chemical Society* 81, no. 22 (1959): 5921-5924.

¹⁰ See Keith R. Jennings, interview by Michael A. Grayson at Leamington Spa, Warwickshire, United Kingdom, 24-25 April 2008 (Philadelphia: Chemical Heritage Foundation, Oral History Transcript # 0419).

GRAYSON: This is all at Wright-Patterson?

FUTRELL: All at Wright-Patterson. Gas chromatography had become an item of commerce [and gas chromatographs] something you could buy. I started buying them and putting weird detectors on the other end, and things like that, and using these new tools to investigate gas phase radiation chemistry. So, within my two year tour of active duty, published <T: 175 min> probably twenty papers or so that were using these I would say fundamental ideas and some improved tools to do things. I also had become an “expert,” okay? I put that in quotation marks, so please do that in the transcript. I became an expert, a scientist, that could be called upon by, for example, Exxon. And Exxon invited me and a number of other people, some thirty outsiders, people who were not employees in Exxon, to go to a nice resort on the Gulf Coast and hear the senior scientists from the Baytown Research Center defend their research programs, and these outside experts were then to advise Exxon on the capabilities of these experts. Okay? Well, I was now an expert, judging the group I’d had the honor of working with [two years earlier]. I was also considering a very attractive financial offer to rejoin them. And I praised them highly, okay?

GRAYSON: Yes. So, you’re actually being called in to assess...

FUTRELL: To judge...yes, that’s right.

GRAYSON: ...the work that was being done by the group that you had left.

FUTRELL: So, imagine how ludicrous it was. [laughter] Poor kid, I’m two and a half years out of graduate school, to be judging Franklin, Field, and Lampe. Completely ludicrous. But it happened, okay? And the entire group composed our report there, and so we praised them, you know, to the mountaintops for the outstanding work they had done, and we singled out the ion molecule reactions, studies that the Franklin, Field, Lampe...other groups as well, [including Henry] Earl Lumpkin, mass spectrometrists, was one of the persons we singled out, and others.¹¹ So many, many people that would be recognizable to...well, by you, Mike.

We wrote a very, very positive report, and especially singled out this as having such major impact in the many fields of science, and being far ahead of the best universities in the United States in this general area of science. We thought we had done an honest job, and we’d

¹¹ See Henry Earl Lumpkin, interview by Michael A. Grayson in Round Rock, Texas, 2 January 1992 (Philadelphia: Chemical Heritage Foundation, Oral History Transcript # 0194).

finished our job. Then because I was flying back to Ohio, the first flight was from somewhere near Biloxi, Mississippi, maybe New Orleans, [Louisiana], I'm not sure, to Atlanta [Georgia], and I [was] on the same plane with two of the people from Exxon who were sitting in judgment. These were corporate decision makers. They were sitting in first class, and I was in tourist class. And so I went up and spoke to them, and they remembered me, of course, we had a nice little conversation. They invited me to sit in an empty seat, and I sat there for a while, chatted with them, and I said, "Well, let me ask you a question, because I'm particularly interested in this group that's working on the gas phase ion chemistry, because that's my interest, too. So, what do you think of them and our recommendation?"

They said, "Oh, we're extremely proud of them. They're doing fantastic work. We really like what those of you who understand the field have said to us." "And so, what are your plans for the future?" I asked. He says, "Well, we think they're too small to have the impact that they ought to have on corporate, so we should either triple their size or eliminate them." Hmm. [laughter] Well, Joe Franklin became a professor at Rice University, Welch Professor at Rice. [Fred Lampe] moved to Penn State [University]. [...] Fred Lampe moved to Penn State, and Frank Field went to Corporate [Research and shortly after to Rockefeller University]. And <T: 180 min> so, the Baytown Research Center lost some of its key people, maybe most of its key people, and probably its place in the sun in terms of being major contributors to certain fields of science. And so, Joe became a Welch Professor at Rice University, did very well there. I continued to interact with him. And Fred Lampe moved to Penn State. I elected to sign on at Wright-Patterson as a civilian scientist, and so I was close to Penn State, and interacted quite a bit with Fred Lampe, and more distantly with Frank Field [...]. But certainly this incredibly productive group of people continued to be productive, but in a totally different venue [...]. So, it's just a magic moment in history that I was able to be there and be part of that.

[Because of these events and knowing these people, I fell] in love with mass spectrometry, despite my misgivings, the first time I encountered it. My immediate dowry to sign on as a civilian was to get my own mass spectrometer, a 21-103C, state of the art mass spectrometer, from the near monopoly that existed...

GRAYSON: [Yes], with CEC.

FUTRELL: ...in making mass spectrometers. Well, let me see. I guess by this time my salary as a first lieutenant was of the order of five thousand dollars a year.

GRAYSON: Sounds about right for that era.

FUTRELL: [Yes]. I think I was going to be a GS14, second highest rank in the civil service system, and that salary was roughly fourteen thousand dollars. At least I remember that way. GS14 equals fourteen thousand dollars—huge raise in pay from a lieutenant, but far short of the

seventy-eight thousand dollars price tag on a 21-103C. [...] That's close to one million dollars in current dollars. That was the state of the art at the time, and it was a big purchase, and because it was a near monopoly, they manufactured [the instrument in a scheduled fashion]. They would build the magnets, and then they'd build the pumps, and then they'd build the electronics, and so on. Once per year they'd have a production line of mass spectrometers. And they were selling well that year, so the sales representative called me up. You know, he knew I was buying it. He knew it would take time for the Air Force procurement system to grind through, get all the approvals for such an expensive piece of equipment. He called me and said, "You know, Jean, we're down to five instruments that'll be available to last the rest of the year. We've got five months to go. That's one a month. I'm not sure there'll be any [left] when your number comes up."

I said, "Well, what can we do?" Well, we worked a deal, and he sold [one of the remaining instruments to me as an individual buyer]. [...] So, when the official bid request came through, CEC responded to Wright-Patterson procurement [...] and said, "We are pleased to honor your request, and our bid is exactly the number that's in your purchase requisition. We can guarantee delivery in ten months. However, there is one order on the books which, if cancelled, means we can deliver it immediately." Well, [that order was cancelled], and I got the mass spectrometer.

Then we had to install it, okay? Install it in a building designed by the [U.S. Army] Corp of Engineers, built by the lowest bidder. Magnet—that was a small magnet, as I look back on it, but it was a heavy piece of instrumentation, and my lab was on the second floor <T: 185 min> [...]. The civil engineers who were responsible for buildings at Wright-Patterson did the analysis and said there was no way the floor in my lab could support such a heavy piece of equipment. Okay? So, my engineering knowledge came to the forefront again. I went back to the books I hadn't opened for a good number of years. I got the plans. I worked out the load-bearing capabilities of the floor—[based on] my introduction to civil engineering course that I had had at Louisiana Polytechnic Institute. And I proved that it would hold up a magnet. And so I confronted the base engineers, and sure enough, here's this troublemaker, once again using these mathematical equations to get his own way. I got permission [to proceed with installation of the CEC mass spectrometer on the second floor of ARL]. Then I got worried. I had not calculated whether the hallway would sustain the load.

GRAYSON: Uh-huh. Getting it in there.

FUTRELL: So, I thought it prudent to be out of town giving a lecture somewhere when it was delivered. [laughter] It was delivered. We had a major advance I had bought as a special accessory, and that was a new recording system. You might remember, Mike, no one else would ever have seen it, but the oscillograph, the light path recording paper, they had an option replacing this with a UV lamp on light sensitive paper, and so you get an instant recording of what was going on. I had bought that, because I knew I didn't want a darkroom. I didn't have one. I didn't want to go through all that. So, we had a way of recording spectra instantly, but we

didn't have very many improvements in the other things. And so, that was the only [technological advantage over earlier models] that existed when it came, and of course, we treated it with kid gloves, and so on and so forth.

One of the interesting questions in your little checklist that you gave me was did I encounter any discrimination as a woman in science. [laughter] And the answer is, well, yes and no. I was never asked to review a scientific paper for five years, by which time I had published over fifty, and I suspect that was sexual discrimination.

GRAYSON: Oh, because of your name?

FUTRELL: Yes. And I didn't know what a good deal I had. [laughter]

GRAYSON: So the assumption was that J-E-A-N was a [woman].

FUTRELL: Yes, I think it was. And I know in this case it was, because we had to treat this instrument so carefully...and you will likely remember it had tungsten filaments that had to be treated overnight. And so, you put isobutane in there and ran it at a lower temperature. Isobutane would form a tungsten carbide surface, and it was the tungsten carbide that was the stable emitter of electrons that gave you the stable operation of the mass spectrometer and so on and so forth.

GRAYSON: That was what they all believed.

FUTRELL: Exactly. That's what everyone believed. I read the manual. I probably have the manual somewhere. I know they exist at CHF as residues of the past. But I read it carefully, followed it carefully. We did all this, and we ordered our gases from Matheson Gas [Products] Company. And something like two to three weeks after this precious new tool had been delivered to the laboratory, the ion source crapped out. It arced. And so, I complained, and CEC was good enough to send a replacement, and another two or three weeks later, same thing. Arcing, self-destruction.

I investigated to find out the cause of the problem, and I determined that there was a trace amount of [iron pentacarbonyl] in the [cylinder of isobutene we had purchased from Matheson], okay? So it's <T: 190 min> something that decomposes at low temperatures into guess what? [Iron] and carbon dioxide. Carbon dioxide we ignored because it was mass twenty-eight. That was the same as nitrogen. Nitrogen was where we started counting our peaks for mass assignment. It was an invisible contaminate that was plating my ion source with [iron]. And then I, you know, used other analytical tools to prove that insulators had [iron] on them. I

used infrared to show that it had [iron pentacarbonyl] in the cylinder. And I wrote a detailed nasty letter to Matheson Gas describing the [problem and its cost to us taxpayers]. I think the ion source [cost] four thousand dollars or something like that, a huge sum of money. I got a letter back that said, "My dear Miss Futrell." [laughter] "What you have described is completely impossible. We are so careful in how we clean all of our cylinders and our laboratory control [procedures assure] that what you describe is absolutely impossible." Okay?

GRAYSON: *Miss Futrell.*

FUTRELL: Yes. And the person made the mistake of signing his name. [laughter] So, I [immediately] called him, speaking as gruffly as I could. "This is Dr. Futrell, not Miss Futrell, and I have the original charts of all the spectra, and every statement in my letter is documented." Well, they [bought us a new ion source] and I agreed to shut up. [laughter]

GRAYSON: And they also went and did better at their gas. [...] Before you go there, I'd just want...you did this transition from the military into civilian life.

FUTRELL: Yes.

GRAYSON: And that was...everybody was happy with that? I mean, you were happy because you were done with the military?

FUTRELL: Yes.

GRAYSON: You'd [fulfilled] your obligation. But you could stay on in this lab now in a civilian capacity and that was not a problem with the VP or the director or so on?

FUTRELL: No, no, no. They were delighted. The commander of the laboratory, because the Air Force came out of the Army, was a West Point [United States Military Academy] person, who had gone on to graduate studies and received his PhD [and became a faculty member at West Point], had switched to the Army Air Corps, and then that became the Air Force. And so, he was very academic in his orientation. [However,] as a first lieutenant, I disappointed [many] of the other military assigned to the lab, because the [custom was that newly assigned officers of lowest rank] had to do all the work [of organizing] the [monthly] officers' party. It was called Officers' Call, where once a month we would discuss items of significance to the military officer corps. This involved alcoholic beverages, and barbecue, and...

GRAYSON: Really?

FUTRELL: ...and the newest, greenest lieutenant was the one who had to bring all this stuff. But I came in as a first lieutenant because I had already served [three two-week tours of duty] and gotten credit for two years [service], and gotten promoted, so I was the senior officer for chemistry. [laughter]

GRAYSON: Oh, wow. [laughter]

FUTRELL: That was fun. And I enjoyed the Officers' Call and so on. And because I had trouble starting up my laboratory, because buying stuff is always complicated, and Wright-Patterson is such a huge military base, it must have had over one thousand officers there at the time, that the original quarters built for Lieutenants were now occupied by Generals on the base, and they had no housing for even Lieutenant Colonels, had to live off base, and certainly I did. But anyhow, [when I reported to] this kind of scholarly commander [...] I came in, saluted like I was supposed to do, and so on. He says, "Oh, sit down, Lieutenant. We do that outdoors in the parade ground."

GRAYSON: Oh, okay.

FUTRELL: "In here, it's different. I've <T: 195 min> looked at your CV. Let's talk about how things are done here." And he described this mixture of [scientific staff], where there were more civilians than there were officers, and the military were typically Reserve officers who came in and left. There were a few regular officers who were assigned there, as he was, and the command staff were all regular officers. And each one of them had at least one civilian to answer questions if they didn't know because of their background what was going on. And so they had this kind of parallel management structure, and the chemistry division was headed by a civilian and so on. Most of the scientists there were civilians. There was a handful of officers that came in and out. A few regular officers, I had the privilege of working with, and it was fun. But there was no problem in making that switchover.

[To get something ordered quickly, the commander assigned a full-bird colonel whose earlier career had been a SAC [Strategic Air Command] bomber pilot, and he was immensely confused when he was assigned to help a lieutenant. [laughter] But we became friends. He never understood it. It was a magic moment in history.

So, what happened is that from being a lieutenant, a first lieutenant who was...if I'd stayed another week would have been a captain, because a promotion had come through. I

[became a] brigadier general. [laughter] In terms of military rank and protocol, GS14 is a brigadier general.]

GRAYSON: Oh, wow.

FUTRELL: A year later I became a lieutenant general, [laughter] or GS15, and so the protocol worked. So, you know, as soon as I moved up to GS15, I was entitled to a private office suite, okay? With carpeting and all that. I didn't bother. I still had an office in the laboratory. I'd been honored at the radiation lab by having my desk in the lab, and so I kept that practice. I stayed in the laboratory, and I actually accepted a small square of carpet that I glued on the floor, and I could point to in case anyone cared. "Yes, I'm entitled to have a carpet in the office, but I don't need one." And [ARL] was really fine with it.

Anyhow, I moved to a senior civilian position. There was a hiccup in funding. I had the money for my dowry to get the mass spectrometer to get started, and funding was incredibly good at that point in time. As soon as I had this one and learned a little bit about how to operate it, I immediately ordered whatever else seemed to be useful, and in particular, it was a time-of-flight mass spectrometer. I thought those would be cool. I think three gas chromatographs, and a few other toys for the laboratory, and all kinds of specialized chemicals. And so, we were off and running, and I got to know people, had gotten to know people in other parts of Wright-Patterson. And to set this in context, this was just the time when double focusing mass spectrometers came into existence, both in England through AEI [Associated Electrical Industries]...do I have it correct?

GRAYSON: Well, there was Metro...

FUTRELL: Metropolitan-Vickers. *They* were the first.

GRAYSON: [Yes]. But, I mean, and then, I mean, they, kind of, smushed together.

FUTRELL: Yes. Sure. Okay. So, Metropolitan-Vickers I think was the launching company in England. And in the United States, CEC introduced the 21-110 double focusing mass spectrometer. What I had learned during my lieutenant days is the prototype 21-110 was built for the Air Force. They funded the development at Bell & Howell [Company] CEC. <T: 200 min>

GRAYSON: Do you know why they did that?

FUTRELL: [Yes]. For the Air Force Materials Laboratory, where they thought high resolution mass spectrometry would be very useful in their Materials Laboratory to do composition of all kinds of stuff. And it was a good call. That was quite correct. They had paid for [the development of the first instrument built in the U.S.], and I [got] to see, the prototype 21-110B mass spectrometer. [First], the prototype was installed and then the first lot of commercial instruments that were sold, Wright-Patterson got this I believe as a replacement for the original research prototype. [...] Charles [F.] Robinson [...] was the [CEC engineer responsible for this development].

GRAYSON: [Yes], that name is familiar. [Yes].

FUTRELL: At CEC.

GRAYSON: At CEC.

FUTRELL: [Charley gave a] two-hour talk [describing how] they developed the mass spectrometer, the various things that had to be thought about for double focusing mass spectrometers, and so on. And so, I buttonholed him after the talk and said, “I’m really interested in that, and I’d like to visit you in Pasadena [California] and learn a little bit more.”

So, I did. Since I already was general officer rank, no problem to get a plane ticket. So I went to visit them and talked about mass spectrometers, and I said, “You know, I’ve had this idea for some time of hooking a mass spectrometer to a collision cell and then putting a second mass spectrometer after the collision cell, because I’ve been making a living writing the ion molecule chemistry to understand radiation chemistry. I’ve been doing that for over three years now, and I know that the way that this sequence is worked out is fatally flawed. If you want to know the identity of the ion, mass spectrometer is the way to do that. Do a real mass selection. If you want to know the neutral, put it in a differentially pumped cell so you know what the neutral is, and if you want to know what happens, put another mass spectrometer on the other end. Now I have no clue of how to do all this.”

[END OF AUDIO, FILE 1.1]

FUTRELL: “But I’d like to come out and talk to you about it.” So I did. Went out, spent a [full] day [at CEC]. We talked about it. And the upshot of that is that I decided, well, why settle for a single focusing mass spectrometer? Why not two double focusing mass spectrometers? And I understood in some detail, I thought, at that point in time, the Mattauch-Herzog geometry.

Nier-Johnson was a newcomer, to my understanding, and I thought I should probably visit Al [Alfred O. C.] Nier before concluding that that was the way to go. So again, a visit to Minnesota was no problem, and I met Al Nier, but he was getting old, Mike. He was, kind of, our [present] age. [laughter]

GRAYSON: This would have been 1960?

FUTRELL: [I think it was 1961.] So anyhow, it was not as informative a discussion as I had thought might happen, but I met several other people at Minnesota who knew a lot about mass spectrometers, and so it was a very good visit. And the net result is I still couldn't decide which would be the best pair, so I said, "Well, I'll take one of these and one of those." [laughter] And asked CEC if they were prepared to bid on constructing such an instrument. And the answer was yes, and so they submitted a contract and so on, and eventually received a contract to build the tandem mass spectrometer, and it was delivered.

GRAYSON: So what was where? You had the Mattauch-Herzog on the front and the...

FUTRELL: Mattauch-Herzog was in the back. [I chose Nier-Johnson for the first stage.]

GRAYSON: Oh, it was in the back.

FUTRELL: Yes.

GRAYSON: Okay.

FUTRELL: So, what the people at CEC told me is they wanted to build a small-scale mass spectrometer for the front end. They asked me what kind of mass resolving power I wanted. After thinking deeply, I thought three hundred. [laughter] So yes, they committed to build a double-focusing instrument that could delivery resolving power of three hundred.

GRAYSON: Right. Shouldn't be too hard.

FUTRELL: Shouldn't be too hard. And they were going to operate it...I don't know why they decided on this number, but at one hundred sixty-nine volts accelerating voltage, okay?

GRAYSON: One hundred sixty-nine?

FUTRELL: One hundred sixty-nine.

GRAYSON: Okay.

FUTRELL: I do not know. I'm sure the world will never know why they settled on that. But that was the operating voltage. [Part of the story is that I wanted low energy ions.] How low can they get and still be confident that their design parameters are solid and so on? Because they knew I wanted to slow the ions down to thermal energies, okay? And they had me come up with a specification [for that], and I think...I thought very deeply, and I said, "One electron volt translational energy." And so, this was it, a whole one page list of all the specifications describing the first stage mass spectrometer, the second stage mass spectrometer, the collision cell, decelerating ions to one electron volt, and so on and so forth. And it was delivered, and it didn't work at all.

GRAYSON: Now did they do any pre-delivery testing at their end?

FUTRELL: Well, yes, they did quite a lot, so I'm quite sure they knew it wouldn't work, and they had given up, [but] they decided to deliver it [anyway].

GRAYSON: You asked for it. Here it is. [laughter]

FUTRELL: Yes. Here it is. And I learned something about procurement and legal dealings. That's a very important lesson, because, you know, I demonstrated it wouldn't do bum bum bum bum bum bum, and they countered saying, "Yes, it does what you say in step one, in step two, step three, and so on, all the way to the bottom of the page."

GRAYSON: You just can't do all those together. [laughter]

FUTRELL: Exactly. Okay? And so, the first stage mass spectrometer did operate at one hundred sixty-nine volts, delivering an ion beam with a resolving power—I think it was close to five hundred. Exceeded specs.

GRAYSON: Right. Yeah, right. Sure.

FUTRELL: Okay? <T: 5 min>

GRAYSON: You're ahead of the game.

FUTRELL: It could decelerate ions to zero. Nothing came through. [laughter] Collision cell had differential pumping, and met [every one of my] specifications. I had left out the [critical] sentence, "Must perform all these function simultaneously." So, I had a collection of very interesting parts.

GRAYSON: I guess. Yes.

FUTRELL: And...well, I entered into a desperate phase of my research, because this was the largest single investment [that ARL had made].

GRAYSON: [Yes], I was going to say, this probably cost a piece of change.

FUTRELL: Oh, it did. I don't remember the exact number, but it was [of the order of three hundred] thousand dollars.

GRAYSON: It was more than [three] mass spectrometers.

FUTRELL: Oh, yes. It was [a lot] more than twice the price of a 21-110B. So, we could do the math by working back in time. And so, to say the least, it was embarrassing to the lab director who had placed his confidence in me to do this. Tremendous disappointment to me. But we learned quite a bit about mass spectrometry up to that point, and we started learning about ion optics. Now ion optics in those days [was somewhat based on analog computing]. There were a couple of ways of doing it. One of the more sophisticated ways used thin pieces of rubber, and you stretch the rubber to mimic the shape of the electric field, and then you put blocks of wood under it where the slits would be to distort the electric field, and then you start rolling marbles. It simulates the ions going out of your ion source. [laughter] So, we had tables set up all over the lab evaluating ion optical designs, and so on.

GRAYSON: Did you ever lose your marbles? [laughter]

FUTRELL: I did. [laughter] Actually, my infant son stole my marbles I had in the lab one afternoon. [laughter] He took [most of them] them home.

GRAYSON: What the heck is my dad doing, playing with marbles.

FUTRELL: Son, our research project. They actually paid me for this. [laughter] And then there was conductive paper. I don't know whether you've ever seen this.

GRAYSON: No, I haven't seen that.

FUTRELL: Uniform carbon-coated paper that you would take conductive silver paint and paint your electrodes and then you would take your voltmeter and measure [voltages at various points on the coated paper]. That's how you got your field plots. So anyhow, I spent several months doing this [and] got nowhere in terms of how to solve the mass spectrometer problem.

GRAYSON: Right. I mean, you knew it should work, but it wasn't.

FUTRELL: That's right, but I discovered I had an electric sector and a magnetic sector, and so you can use those for energy selection and mass selection. What can you study with that? You can study metastable ions, okay? I said, "Aha, we'll just investigate metastable ions in a double focusing mass spectrometer. By the way, I have two of them, that I can really study metastable ions." And so, we started doing that. And that involved extending the absolute rate theory in the other direction to go into longer times, and that's a place where another key person enters my life. His name is Marvin [L.] Vestal.¹²

GRAYSON: Crazy Marvin.

FUTRELL: Crazy Marvin, yes. [laughter] That's the one. So Marvin L.—I think it's Leon—Vestal, and you know how to spell it.

¹² See Marvin L. Vestal, interview by Michael A. Grayson at the Orange County Convention Center, Orlando, Florida, 3 March 2010 (Philadelphia: Chemical Heritage Foundation, Oral History Transcript # 0680).

GRAYSON: Yes.

FUTRELL: He was an undergraduate at Purdue University. And an entrepreneurial professor named Bill [William H.] Johnston had another person working for him named Henry [M.] Rosenstock, and somehow decided paying a call on me [to talk] about things they could do for me to help me to understand things I was doing. And Rosenstock was of course the magic word, and so I said yes. So we all developed a research contract to Professor Johnston at Purdue University to extend absolute rate theory, in ways and means that I would specify as the person in charge of the project. And then Rosenstock left and got a real job at the [National] Bureau of Standards, and I had the choice of either keeping this <T: 10 min> project or killing it, because I had written Rosenstock into my purchase requisition.

And I decided to bet on Marvin Vestal as a person who could [replace Henry.] He seemed to be a really, really bright guy, even though he didn't smoke cigars, or have white hair, or a beard in those days. He was a really, really smart guy, and so I got connected with Marvin Vestal. Bill Johnston decided to leave Purdue and form his own company, Johnston Laboratories Incorporated, in Baltimore, Maryland. And I transferred the contract with him. And Marvin was helpful to me in my understanding of absolute rate theory and doing [many] things [over the years], and we were coauthoring papers during that period of time.

In the meantime, I completely broke my pick trying to understand how to make the machine work for other purposes, and I made a critical visit by identifying the National Bureau of Standards, now NIST [National Institute of Standards and Technology], as a place where the most sophisticated charged particle optics in the United States is being done. Later on, I got acquainted with the people in Europe who were doing it, and so on. I took my problem to the National Bureau of Standards. I took blueprints for a critical part of the machine. By this time, I had measured the properties of [the apparatus, and our experiments, and] everything else, kinetic energies, to a gnat's eyebrow. [I knew all the properties of my primary ion beam and] I knew the characteristics of the Mattauch-Herzog from the place the normal electron impact ion source would fit. I took all this information with me to the Bureau of Standards, where] Chris [E.] Kuyatt and John [A.] Simpson were the two science leads. Mainly, they designed electronic optics for advances in electron microscopes. That was one of the main activities that they did. But charged particles are charged particles. And so, I spent an incredibly productive day...I think I signed up for two days, so it may have been a little more than a day, there, going over my problem. They got out all kinds of reference books. They took charts [and graphs and] extrapolated them, [...] went way beyond the ranges where these relationships applied, and invented a new kind of electrostatic lens, and it goes something like this. It's the electric field gradient that influences the motion of charged particles, and what you would ideally like to have as a lens is an infinitely thin aperture or an infinitely thin slit, because then you don't have [to consider the finite size of the conductor that comprises the lens element] as a minor perturbation on the optics. And so all the equations and so on refer to this infinitely thin object.

But the brilliant idea they had is suppose we have two field gradients, okay? So, we deliberately make it a thick slit, all right?

GRAYSON: Okay.

FUTRELL: And we end up calling that a slot. Okay? And if you have a slot lens, then you have two field gradients, and then you can sort of double the strength of your lens, okay? So, that was the concept. And then they did some corrections I never understood for the width of the slot, and so on. The upshot of that is that within about ten hours, [they] had a design that would take this ion beam, put it into a tiny hole going into the collision cell—into my collision cell. [Next,] they discarded the store-bought lenses for the Mattauch-Herzog and designed a simple [known] lens [design that was much more compact]. And I thanked them profusely and took my notebook and went away, but not before I visited Rosenstock and Wallenstein and their colleagues at the Bureau of Standards. [...] By this time they knew me, and [they asked] what are you doing here? I said, “Well, I’m <T: 15 min> coming here to have the people on the charged particle optics [section] help me with a problem. [...] “You guys are so lucky to have these people right across the street.” They said, “Oh, who are they [laughter] and what do they do?” So anyhow, communication is difficult, and team research is still the great concept that sometimes works.

GRAYSON: Well, different buildings are great separators.

FUTRELL: [...] At any rate, I came back and [had] these things built, and they had to be the special metals and everything else to be suitable as lenses. In the meantime, that summer, I had a distinguished visitor come from England whose name was Keith Jennings—K. R. Jennings. And Keith had learned about me indirectly from his photochemistry friends, and came over to the Colonies, as he called it, to begin to make the acquaintance of some of the American mass spectrometry folks. [laughter] And I was one, and I had [some] money, and so he could come for a three-month visit. So, we essentially paid a summer salary kind of stipend for him to join us, and [this was the] great beginning of [our] friendship, that continues to this day. I’m speaking at his eightieth birthday retirement in December [the Warwick Mass Spectrometry 80/60 Conference].

GRAYSON: Oh, great.

FUTRELL: In England. We just got our tickets. So anyhow, Keith was there, and he was just getting into mass spectrometry at the time, and he had a double focusing machine. And I believe it was the first day, maybe the second day after the rigmarole of checking in had been finished, completed, and so on. As a foreign national, as a, let’s say an ally during the Great War, both Great Wars, it was more complicated than if he had been a Russian.

GRAYSON: Really?

FUTRELL: I'll come back to that story in terms of Talrose.

But anyhow, Keith was checked in, and we were in the laboratory, and starting to talk about science and so on, and showed him all the wonders, showed him the functioning 21-103, and this [dysfunctional tandem that was two spectrometers connected together by plumbing, not lenses], and I said, "But in the meantime, we've learned how to use this. And we've invented this decoupling of the two sectors, so we can look at metastable ions. And this is the article that I've written." He said, "Oh, that's very interesting," and he reached in his briefcase, pulled out the article he had written, same invention, same idea, exactly, using the electric sector to energy select the ions.¹³ And [this was] the invention of what was called the decoupling technique—sorry, defocusing technique. I always called it decoupling when I described it because you didn't change the focus. You decoupled the electric and magnetic sectors for a different purpose.

So anyhow, we played around with that. We published a couple of papers together.¹⁴ And by this time, by [the end of the summer], the lenses had been built, and we could reconstruct [the reconfigured and deploy it for its intended purpose]. Jennings had gone back to England, and we installed this, and much to my delight, it worked, so we were off and running. And we had learned enough optics that we had to do a number of things that had not been done for us in the machine that had been developed in California. We had to put in an ion source that made a lot more ions. So, we had to make a hotter ion source, so to speak, and that was, you know, increasing the number of electrons you shoot through and the aperture sizes—slits, actually. And then we discovered we lose so many ions throughout this long trajectory in that instrument, and so we added focusing elements, and let me see. Would that be called Z-axis focusing? I've forgotten. At any rate, you could increase the transmission efficiency of a double focusing machine by more than an order of magnitude. **<T: 20 min>** And since we had [five] sectors, we [...] needed three orders of magnitude more than had been given to us by [the manufacturer].

And so, we put these added lenses throughout the system, and so we did a lot of things ourselves to make it actually work. And we put electronic multipliers on the other end. And we did pulse counting of electron pulses, and I think we were the first people ever to do that on a mass analyzer, other than a few physicists who did special things. I know we were the first ones to put a multiplier on the Dempster machine, on the 21-103, because we had to invent a way of getting the ion beam out of the magnetic field to have a multiplier work. And so by this time, I'd

¹³ J. H. Futrell, K. R. Ryan, and L. W. Sieck, "," *Journal of Chemical Physics*, 43, (1966): 1832.

¹⁴ K. R. Jennings and J. H. Futrell. "Decomposition of tropylium and substituted tropylium ions." *The Journal of Chemical Physics* 44 (1966): 4315; , Gillian C. Goode, Gillian C., Rebecca M. O'Malley, A. J. Ferrer-Correia, R. I. Massey, K. R. Jennings, J. H. Futrell, and P. M. Llewellyn. "Rate constants for ion—molecule reactions determined by ICR mass spectrometry." *International Journal of Mass Spectrometry and Ion Physics* 5, no. 5 (1970): 393-405.

done enough reading, I knew if you put in a Wien filter...so, you have an electric field that balances your magnetic field, and to get it through a field gradient, I had to build an electric field gradient that exactly matched the magnetic field gradient, and so then the ion beam would be extracted directly to the magnetic field. I could shoot it into a multiplier, and at one fell swoop we increased the sensitivity of the old mass spectrometer by a factor of a million. Then we could do many more interesting experiments with it. And so, it was a whole series of papers where we used the old CEC machine to study very low energy ion molecule reactions and so on.

[With the new optics our tandem exceeded all our specifications (simultaneously), and we] discovered we could decelerate down to 0.3 volts, and [our novel deceleration lens exceeded the best results reported in the literature by a factor of fifty]. And so, it was really a remarkable lens. It entered the literature [as a standard lens design and is] called a rectangular [...] slit lens, and was copied in quite a number of beam machines and other things. Never used commercially, to the best of my knowledge, except by us. So anyhow, we had the bear by the tail. We could do ion molecule reactions out the wazoo. So, then...

GRAYSON: Let me ask, you did all this, essentially kind of home brew ion optic modification in the machine.

FUTRELL: Yes.

GRAYSON: So, you had to have pretty good support in the shop somewhere...

FUTRELL: Sure. We did. We had to have excellent shops. And the key person [in solving our problems] was Dean Miller, who was my electronics guy, okay? He was a person who had been in the Air Force, worked as a civilian at Wright-Patterson, and I actually promoted him and got him to come to my lab from somewhere else at Wright-Patterson Air Force Base. And so, it was his knowledge of electronics, how to do pulse counting...you know, without him, I would have been an asterisk somewhere. [laughter] And the machine shop was first class. The glass shop was first class. [...] I've known this all of my life [that support people and support shops are terribly important.] So in my university careers, I always built up the shops to enable faculty to do things that I could do, for example, could not do without that. And so, [Dean was] coauthor on an [impactful tandem mass spectrometer paper].

GRAYSON: Oh, okay.

FUTRELL: And it was heart-breaking to me, I couldn't attract him to Salt Lake City, [Utah], when I moved out there.

But at any rate, we were off and running, and it was like a rocket taking off, because we could [determine unequivocally the products generated by reacting a specific ion with a specific molecule, and we could easily repeat experiments that were reported in the early literature and correct a number of mistakes]. I [also learned] that was not a popular thing to do: correct errors in literature.

GRAYSON: Yeah.

FUTRELL: Explain what ions really do. [laughter]

GRAYSON: Well, you know...

FUTRELL: [Yes], well, it's always disappointed me that scientists are people. [laughter] There are distinguished names I could mention, [but I won't. I gave an invited talk in 1966 at a well-known institution and a research director described their recent painstaking study of a <T: 25 min> sequence of ion molecule reactions. Three big names in the business were involved in this, as visitors and toilers in the vineyards. [...] My invited talk seemed to annoy them rather than please them, [and I thought I was being helpful when] I said, "Well, it'd take me twenty minutes to just check this out, see whether you're right." So, I went home and in twenty minutes I had done it and they weren't right. And so, I sent them the graph, I sent them a note, and I said, "You might want to revise your paper." "No." [laughter] They didn't revise the paper.

[There have been a few] incidents like this, where I tried to help people. I guess I should put that in quotes and discovered to my amazement that they weren't at all pleased, and the [suggestion] of coauthoring papers somehow didn't appeal to them when it [contradicted their published work.] And I even became known to editors to a few key journals. [One of whom said,] "There's nothing wrong technically with your paper, but one does not refer to one's colleagues using the kind of language that's in your paper." [laughter] "And I will not publish it unless you change it." That was another piece of very good advice. [laughter] It ranks right up there with getting a house near the airport. And nothing to do with science per se, but very, very good human relations [...advice].

GRAYSON: [Yes]. Young whippersnapper.

FUTRELL: [Still a kid from Dry Prong.] So, if you read a few of my papers [very] carefully, you'll find footnotes where I said in the text that this [finding is in general] with the authors, blah blah blah, but the footnote, it says, "Mass assignment was wrong in their paper, so it's really what I say it is."

GRAYSON: Oh, okay.

FUTRELL: And so on. So, that's a far better way to present new information.

GRAYSON: So to speak.

FUTRELL: Yes.

GRAYSON: There's something else I'm curious about, before you get too much further along, and that is why did you come into the civilian side at such a high level compared to your... I mean, from G5 to G14 is... I mean, you've got a PhD...

FUTRELL: Sure.

GRAYSON: ...and you had some experience in...

FUTRELL: [Yes], it was simply because the lab commander, [Colonel Mallory], the person who had this West Point teaching experience, was totally on my side. He ended up, by the way, when he retired, [as] professor at some state college in California, I've forgotten exactly where it was. And so he went back to his academic beginnings, so to speak, after he retired from the Air Force. His name was Eugene Mallory, [...] my success at Wright-Patterson [very much depended on his support As I look back at that point of my career, I want] to mention that part of my instantly moving to the top [...] as a civilian scientist [may have been the] tragedy that Jean Dubois was killed in a plane crash.

[As you may have inferred,] when I was launching my civilian career, there was lots of money [at Air Force laboratories, but this changed suddenly when] I suppose there was an administration change [...]. All of a sudden there was no money. And so I was planning to go to the Pittsburgh Conference back when it was held in Pittsburgh, [Pennsylvania]. Wright-Patterson typically sent, oh, three hundred or four hundred people, [to this particular nearby technical conference].

GRAYSON: Oh, wow.

FUTRELL: A huge contingent, because the Air Force Materials Laboratory was centered there. The Strategic Air Command was centered there. Then our Fundamental Science, and the Air Force Institute of Technology had a graduate school operation there at Wright-Patterson. So, a large contingency. But because of budget constraints, we had to decide [whether Jean Dubois or I would represent ARL this particular year] I could not go, and <T: 30 min> I'd been the previous year, and so he went to PittCon, Pittsburgh Conference, in Pittsburgh. And then a planeload, pretty much [filled with] Wright-Patterson scientists and engineers, on the final leg of their approach to the civilian airport in Dayton, Ohio, [...] had a head-on collision [with a single engine private plane. This accident] killed everyone on board. And so something more than eighty people, close to one hundred people from Wright-Patterson, senior engineers and scientists, were killed.

GRAYSON: Gosh.

FUTRELL: And I had the problem of going to tell his widow about Jean Dubois's death. And this automatically made me the chief person in kinetics, reaction kinetics, and so responsible for that part of Aerospace Research Laboratories, which meant I had to make more trips to Washington, D.C., and represent them in various places.

[We did so well technically that Headquarters requested] a review by the National Academy of Sciences, [to validate us scientifically] scientifically, and so I had to present our part of the program to a set of visitors, very distinguished [set of] visitors. Three of them had been my professors at Berkeley, two Nobel laureates. And I was brash enough by then to invite them to go to the executive dining room [at Wright-Patterson, a privilege that had just been extended to me]. Most people there spoke Yiddish, because they had been recruited from another culture...

GRAYSON: Oh, wow.

FUTRELL: ...besides mine. And then there was a German group that had been brought from Peenemünde [Army Research Center] and those places, okay? So one of the other things I turned down in the Air Force was a chance to be the right hand person to Hans von Ohain. You can [review his story] at the Aerospace Museum in Washington, D.C., because he was the inventor of the jet engine in Nazi Germany.¹⁵ He was [our] Chief Scientist of the Aerospace Research Laboratory. He was the civilian counterpart to the Air Force Commander. And he liked what I was doing, so he wanted me to be his personal assistant, but I decided I'd rather be my own person. [Anyhow, I] had interesting conversations with him, [and] I solved some

¹⁵ Hans von Ohain donated his papers to the Smithsonian National Air and Space Museum. The finding aid is here: http://airandspace.si.edu/collections/artifact.cfm?object=siris_arc_229697

interesting analytical problems for him. Absent my mass spectrometer, the supersonic mach 20 wind tunnel that he cared intently about would never have worked. That's a gross exaggeration. Somebody else would have solved the problem. [laughter]

GRAYSON: He wanted a mach 20 wind tunnel?

FUTRELL: Yes, he did.

GRAYSON: And this was weird. Must have been reentry or something...

FUTRELL: Oh, yes, yes, yes. They had interesting problems. And I had a number of interesting experiences dealing with some of these questions. But to create mach 20, you heat the air like crazy, pump it up to a high pressure, expand it into a high vacuum, [a huge and complex facility].

So anyhow, I talked to the people in this review committee, and they were impressed. They said they were particular impressed with what I was doing and the people that I represented, including some physics persons that reported to me. And <T: 35 min> I said, "So everything was good, right?" They said, "Well, yes and no. We'll [also mention] in our report that you're [very] expensive and so one could get more bang for the buck at a university. You, young man, are smart enough that you should be at a university." [laughter]

GRAYSON: Oh, wow.

FUTRELL: So, that was fairly pointed advice. And I was in the meantime getting lots of inquiries [from university search committees]. I decided to, you know, put the shingle up and see who saluted. I was in the right place at the right time, because universities were expanding. There was money. In fact, the year that I entered my academic career was—[...] per capita [academic research funding] peaked in the United States. And so my setup package, although very modest, and actually reneged on—they never gave it to me—was immaterial, because I had three research grants before I showed up for duty. So anyhow, things were going great guns. We [...] got a very good report, but a mixed blessing, so to speak, from the review committee, and I was being tempted by several universities. The [University of] California system was expanding. [University of California], Irvine was one I decided I might go to, University of California, Irvine. Also, University of Utah, because that's where Henry Eyring and absolute rate theory and Austin Wahrhaftig were. Certainly mass spectrometry was not a dirty word there, and physical chemistry was the lead department there. And there were a couple of other schools that I was thinking about, not too [seriously].

And Ronald [W.] Reagan impacted on my career, because he was elected governor [of California]. Not his first day in office, to pick a phrase from the current political terms, but his first week in office he [suspended] appointments of new faculty, senior faculty, at University of California campuses, and all construction programs...

GRAYSON: Wow.

FUTRELL: ...until the new administration could review and either endorse them or not.

GRAYSON: Of course, I guess he came in on this: Let's get the budget under control.

FUTRELL: Exactly. Exactly. And so California was going bankrupt, something we've heard before. And it was all true, of course. But anyhow, I'm now on a University of California, Irvine Advisory Board, [who had a set of plans for their chemistry building] that didn't get built for another ten years. And I know the California system includes money for instruments, and my appointment, had it ever materialized, would have included at least mass spectrometers.

Well, I settled for Utah. It was a great decision. [...] You know, there were questions. Could I make it in a Mormon environment? You know, and would I be able to launch an academic career that would come anywhere close to competing with what was a going concern?

GRAYSON: [Yes].

FUTRELL: By the way, the time-of-flight mass spectrometer that I bought [at ARL] had an ion source designed by Joe Franklin for them to do a chemical ionization, and I had bought it, and the extra pumps and so on, and it didn't work, either. So, I had to learn more than I wanted to know about time-of-flight mass spectrometers, and I learned how to make it work, and this got me into a very close relationship with Bendix Corporation for time-of-flight mass spectrometers. [This becomes significant after I move to Utah. My first consulting job as an academic was with Bendix.] And so anyhow, I was leaving a lot of things behind, <T: 40 min> [and there were] a lot of unknowns, uncertainties. But intuitively I knew it was what I wanted to do. I wanted to move back to the West. It was not California, but it was getting back in the West, that had some appeal to me. And having met Henry Eyring and some of his people, being keenly interested in that theoretical framework, and doing experiments that relate directly to those theoretical predictions, all seemed to suggest that it made sense to do that.

And so I decided to make the jump, and become an experimentalist working on some of the central themes [that] Eyring, Wahrhaftig, and other folks, [J.] Calvin Giddings, gas chromatography, some really good people [cared about]. I was the start of the new expansion of

the University of Utah, where they had resolved, for whatever reason, to stop hiring Mormons [to fill their vacancies].

GRAYSON: So, that was primarily a Mormon institution?

FUTRELL: Yes. Sure. So, their new president, [James C. Fletcher], had been the head of the Jet Propulsion Laboratory—a physicist—and so he was the new president of the University. He had completely new ideas, okay? [Fletcher] wanted [well-meaning faculty search committees to stop using the appeal of residing near the Mother Church as a recruiting tool]. He wanted to hire the very best people you could find, and he [knew how CalTech and its associated Jet Propulsion Laboratory operated in Pasadena]. And he wanted Utah to [proceed] in that philosophical framework. And so he said, “You hire the best people. I don’t care what they cost. Hire the best people, and I want them to be doing something that’s of current scientific interest, and I can do the math, and I can explain it to the legislature, and everyone else, that someone who comes in and is funded to do research will bring in the students, that he will build the reputation of the University, and every dollar brought in from federal sources will be spent [in our state] at least five times over and they will be providing revenues to the state of Utah, and I can persuade them to put funds into the state university.” Well, that was the hang-up. That’s the hard part, is convincing them to do the final step of investing in the state university. That was his mantra, and so I was kind of swept in in that timeframe. And as I said, I had three funded research grants by the time I showed up [in between]. I went from Wright-Patterson to Berkeley [for the summer] to have a crash course in learning to be a [professor and my initial grant writing effort proved superbly successful].

GRAYSON: So how did that work out?

FUTRELL: Well, it was fun. It was great fun to be there and to visit with people. I was reminded how much I didn’t learn from various people, teaching skills, and the ones that I liked. [...] It was an environment that was different from Utah, but I had in my imagination that it was going to be the same kind of school.

GRAYSON: That was the objective.

FUTRELL: That was the objective. Okay? And I already had the money to buy an ion cyclotron resonance spectrometer, and the president of the University thought I was getting a cyclotron. He was a physicist, so he brought over a couple of his cronies from the National Academy to see my cyclotron when that [came to campus. He was disappointed my magnet was so small]. And so, you know, he didn’t really know what I did, at least not at first.

[Teaching would also be a challenge.] I read some very advanced textbooks that were used at Berkeley, and <T: 45 min> so that's how I assumed students had learned a lot since I was a student, and that's the story behind the ridiculously low grades, the first exam that I gave. [I mentioned this earlier in my interview that the first exam scores were terrible.] But, you know, again, I do what I always do. I confront my problem. And so, I told the class afterwards, I said, "You know, this didn't work. This simply did not work, and so obviously my assumptions that you were reading and understanding the textbooks, and then if I asked if you had any questions, you would ask them, is not correct. And so, my lectures have been starting at the wrong level, and so I'd like to come to your level, [...] and I'd like you to come up to mine. For the next month or so, maybe two or three months, I don't know, however long it takes, I'm going to come here every evening for three days of the week, and I'll stay here as long as anybody is interested in asking questions and talking about what we're doing. And I'm also going to have all the TAs attending my lecture. They're going to sit here in the same room so they know [my lecture material], and I'm going to have a special session with them to make sure they understand what I'm saying before they are assigned as your teachers, as intermediaries. And we're going to do a better job, folks." Fortunately it was before we had all the, you know, social media ratings of teachers. Otherwise, I would have been fired. [laughter]

[Two months later], I was promoted to full professor at 32,000 feet. I was on a trip back East to ask for more money, and the faculty thought I was doing pretty well, so I moved up from [untenured] associate professor [...] to full professor with tenure, and that happened in the first four months that I was at the University of Utah.

GRAYSON: Oh, okay.

FUTRELL: So, it was a meteoric launch. I didn't get to bring anybody [from my Wright-Patterson laboratory] or the tandem mass spectrometer or anything [else] out with me. What I got as my dowry was an offer of enough money to buy an oscilloscope and also access for one day per week to the departmental Mattauch-Herzog mass spectrometer.

Well...that's what I started out with as my instrumentation at the University of Utah. But within the first four months, I got funded to [...] buy one commercial cyclotron ICR, and buy two magnets for building my own versions of cyclotron resonance mass spectrometers. And in the second year, money for a time-of-flight. And so we were equipment-wealthy within the second year of starting things out.

But the first year, I had the 21-103—sorry, 21-110B—mass spectrometer. And I *knew* I could study metastable ions, so I decided to do something else. I decided to investigate collision-induced dissociation of ions. So, what would you expect me to do, based on the story so far? Well, I'll save you asking the question. I'll tell you what I did. I installed a differentially pumped collision cell. I put in a differential manometer to measure the pressure in the collision cell. I put ion optics ahead of that cell and after that cell, so I can make sure all the ions went in, and that I could scan the angles, and integrate over all the ions that came out. I did the complete

collision-induced disassociation experiment and I was the third person to do it. Some guy [back East], maybe you've heard of him, Fred [W.] McLafferty?¹⁶

GRAYSON: Oh, [Yes], I know Fred. [laughter]

FUTRELL: [Yes]? Do you know Fred?

GRAYSON: I know Fred.

FUTRELL: [Yes]. Fred McLafferty, conventional wisdom is that he <T: 50 min> discovered collision-induced disassociation [CID] of ions, and that that was just an extension of the ordinary mass spectrum, where you re-excite the ions, and then they decompose. And he did that. I think it may have been Frank Tureček, I'm not sure which postdoc coauthored the paper.¹⁷ Frank is now at University of Washington. But they did [CID] by loosening a bolt [to leak] laboratory air [into the flight tube] to induce the disassociation.

Okay? Meantime, across the pond, my new bosom buddy and friend... I mean, I'm the Colonial and he's from the U.K. [United Kingdom]... Keith Jennings, just [switched] the bakeout heaters on and baked off whatever crap had accumulated during the week. And that's why [Europe] thinks he discovered collision-induced association. And I did it correctly—[but nobody cares].

GRAYSON: Okay. You actually introduced the gas?

FUTRELL: That's right. And because I introduced the gas, I knew what the gas was, I knew [collision] cross-sections, and I could scan the ions and get the whole spectrum, and I could show quantitatively that it was just a re-excitation of ions and RRKM [Rice–Ramsperger–Kassel–Marcus theory] absolute rate theory [accurately] describes what's going on. But by the time that paper was written, nobody was excited about [by these details]. Anyhow, I did it my way, and that's just a different approach to doing it. So more fundamental, I guess, rather than discovery science kind of thing.

¹⁶ See Fred W. McLafferty, interview by Michael A. Grayson at Cornell University, Ithaca, New York, 22 and 23 January 2007 (Philadelphia: Chemical Heritage Foundation, Oral History Transcript # 0352).

¹⁷ Tureček, František, Fred W. McLafferty, Brian J. Smith, and Leo Radom. "Neutralization-reionization and ab initio study of the CH₂:CHSOH to CH₃CH:S:O rearrangement." *International Journal of Mass Spectrometry and Ion Processes*, 101, (1990): 283-300.

GRAYSON: [Yes]. Pre-planned or...there's a little bit of thought, forethought.

FUTRELL: [Yes]. I have utmost admiration for discovery science, and nothing pleases me more, when something works out wrong, because if you look at a recurring theme in my life story, it's things went wrong and I somehow had to fix it and discover interesting [new insights] to what was going on.

So the other thing that we did on [our own Mattauch-Herzog departmental instrument], and we were funded to do, actually by industry, [...] by CEC, which certainly was Bell & Howell by that time, was to [implement] chemical ionization onto the Mattauch-Herzog 21-110. Now more or less at the same time, Austin Wahrhaftig and I had become consultants to Marvin Vestal's company. It was [William H.] Johnston Lab Incorporated, initially, and then it was reborn with a different name. And one of the things Marvin did, [which] earned a fair amount of money [for Johnston Lab], was putting chemical ionization onto anybody's mass spectrometer, and so that's what he was doing. And Austin was a tremendously knowledgeable, smart person. Both of us were consultants to Marvin's company, and so we stayed engaged and working with him. And I knew how to do it for my own mass spectrometer, and the key problems for putting it on a high voltage ion source is electric discharges, and something called the Paschen-Bach curve—I don't know whether you've heard of it or not. But if you look at the minimum voltage it takes to strike an electric discharge, it turns out to be awfully close to one torr pressure, which is kind of a semi-standard operating pressure for chemical ionization ion sources. And so like it or not, you're in the region where ion [discharges] are easiest to establish and hardest to get rid of. [Our solution was to construct] a spark suppressor by putting a series of glass encapsulated resistors. [...] I knew [about] this from having taken apart quite a number of electron multipliers by then, so to get the same resistors, you can build up a resistor chain with gold-plated mesh in between. And so you establish a field gradient that **<T: 55 min>** moves you [down in voltage and] up the Paschen-Bach curve [...]. And so you can completely suppress the electric discharge. And you have to put your gas source [...] further away from the ion source to make it work.

Anyhow, we did [all this and] it was funded by industry, and the people who were interested came to see it. They were interested in learning how to do it, and they were totally convinced it wouldn't be interesting [since it would not be a sensitive ion source] simply because you lost so many ions in going through a complex path and extracting only small fractions here, there, and everywhere. It was not a sensitive [source in terms of ion current out,] but boy, do you reduce the noise. As long as you reduce the noise by orders of magnitude more than you reduce the signal *and* you had a signal, then you have an analytical technique that works. So anyhow, the people from Bell & Howell, formerly CEC, brought test samples. They were then doing surface ionization as a competing technique, so to speak. And they brought some of the same samples, and we introduced them, and it [to our mutual amazement took] two or three days to pump the stuff out so we could run a second sample. [It turns out that] chemical ionization is [a very] sensitive ion source, and it never occurred to me that that would be true. We were using it without thinking about it or comparing it really to electron impact source or anything else. And so the reason it is so sensitive is that if you have a higher pressure in the

source, you're stopping more of the electrons, you're making more ions to start with. Secondly, ion molecule reactions give you a product ion at every collision, and so your cross-section is huge...

GRAYSON: Is humungous.

FUTRELL: ...for making ions, and so you convert many more electrons into ions ultimately than you can [effectively] use analytically. And so it's obvious when you describe it. But we had never...

GRAYSON: Thought about it.

FUTRELL: ...never thought about it up to that point in time. But then Marvin's company was very interested. Hey, you can make very sensitive ion sources for mass spectrometers, and so on. And so, we did that. And then very much to my surprise and delight, after we were building all sorts of toys at the University of Utah, Marvin sold his shares in the company. I think the company was sold in its entirety. And he had enough money to complete his PhD anywhere that he wished, and he chose to move to Salt Lake City and do his PhD at the University of Utah.

GRAYSON: Oh, there you go.

FUTRELL: And by this time, I knew what needed to be done, so we created the interdisciplinary degree in chemical physics so that someone who was primarily a physicist and a theoretician in terms of his published works would meet the criteria for that graduate program. I believe Marvin was [Utah's] first PhD in chemical physics. I do know I created that program, interdisciplinary program, at the University, and several more of my students got degrees in it.

And so Marvin joined us, and we did all kinds of wild and interesting things, because the notion something is impossible is just not in his lexicon. [laughter] Willing to tackle anything. We decided, hell, let's go for broke. I need ions to do the experiments I want to do. I'm interested in ion molecule product ions. Let us build the ultimate sensitivity chemical ionization source. Okay? How are we doing to do that? Well, <T: 60 min> Marvin and I totally agreed, you take every parameter and increase by ten, okay? So, you increase the energy of the electrons by [about] ten [...]. We increased the pressure by a factor of ten, and so on and so forth. We increased the size of the ion source so we could make sure every ion reacts. We hit the on button, wait expectantly with the electrometer, nothing. What comes out? Nothing. Okay? We check everything, you know. Everything is wired up perfectly. We decide to put [a negative] voltage on the repeller and measure ion current [...], inside the source [using an electrometer]. Lots of ions. [...] So, ions are there, and they don't get out. Hmm. Well, let's rethink this.

GRAYSON: You were making them, but they were stuck.

FUTRELL: Yes. What is the normal state of matter? Neutral. What happens if you make ions and you have enough ions that the electrons are all stopped in space? Well, they recombine. [What happens when] they recombine? They're neutral. They don't get out. [laughter] [...] You don't want to build an equilibrium source. You want to build a *non-equilibrium* source for chemical ionization. We had acquired by this time a [MAT] CH-7...

GRAYSON: Oh, wow. Okay.

FUTRELL: ...mass spectrometer, okay? So, Marvin and I decided to make CH_7^+ . Why not? It would be really neat. Observation and...

GRAYSON: CH_7^+ ion or CH-7 mass spectrometer?

FUTRELL: Well, both. [Make CH_7^+ and detect it using a CH-7 spectrometer]. So we built a source, we chilled down the liquid nitrogen temperature...

GRAYSON: These were all experiments that never worked, I guess.

FUTRELL: Right, and we never got CH_7^+ ...

GRAYSON: But you had fun.

FUTRELL: We had fun. We had a lot of interesting, weird results. And I used the CH-7 to publish the [...] first paper and one of the very few papers that I published on sequencing of peptides, and I was the first person to do it by chemical ionization mass spectrometry¹⁸. You do a proton transfer, probably to the amino terminus of a peptide, and you choose a reagent ion that's energetic enough that you can break the bonds, and you can start with low energy, you'd

¹⁸ W. R. Gray and J. H. Futrell, "Application of Mass Spectrometry to Protein Chemistry 2. Chemical Ionization Studies on Acetylated Permethylated Peptides," *Biochemical and Biophysical Research Communications* 41 (1970): 1111-1118.

see the intact ion, then more energetic, lower proton affinity reagent gas, and break it. [That was presented at an International Mass Spectrometry Meeting,] I think it was in Brussels [Belgium] meeting.

I was talking to biologists, and I had a student who was interested in doing [this kind of research]. I would have pursued it, except the student lost interest, went somewhere else. In academia, that's what I learned. If you don't have a student who's sufficiently interested to do [work on the] problem, do experiments that fail to work over and over again, then you're probably not going to succeed in doing that.

So, we did the MS30, which was a parallel beam oddity mass spectrometer, and so we built a chemical ionization source for one beam, and the electron impact source for the other, and so we had our calibration spectrum on one side, and the chemical ionization spectrum, whatever it was, on the other side. We could leak samples into both sources and get those results.

GRAYSON: Simultaneously?

FUTRELL: Simultaneously. That was kind of interesting. It was obvious that putting a computer on the mass spectrometer was an interesting and important thing to do. I made a mistake of deploying too many resources to do something that was [so] obvious, that other people would work [very hard on the problem]. But we were among the first, maybe the first, <T: 65 min> to actually—I think the first—to actually put a computer on a quadrupole mass filter mass spectrometer. I got involved with Bob [Robert E.] Finnigan, when he was at SRI [Stanford Research Institute], before he branched off to form his own company.¹⁹ And I actually had acquired two quadrupoles, one at Wright-Patterson and one at Utah, from Finnigan, when they were still made at Stanford Research Institute. And I did a number of experiments with this. [...] IBM [introduced] a laboratory computer, and I've forgotten what they called it.

GRAYSON: Was this when they were trying to break into the analytical instruments?

FUTRELL: Yes. They were, trying to break into analytical instruments, and so they built this laboratory computer, and we used it to interface the quadrupole. That was the simplest [task], because we knew the theoretical peak shape and so on, you only needed a fraction of [data points over] the peak to assign the mass, and then we could calculate the area from [the same data]. So we did that successfully, and we actually interfaced a magnetic sector machine based

¹⁹ See Robert E. Finnigan, interview by David C. Brock at Los Altos, California, 4 December 2001 (Philadelphia: Chemical Heritage Foundation, Oral History Transcript #0227).

on a bizarre idea. And so the idea was to sweep the electric field, and of course, you're sweeping that when you sweep the mass spectrometer. And so, one of my postdocs' wives wound a wire on a bobbin from a sewing machine and inserted it in the magnetic field, and we measured the voltage developed when it was scanning [...] by running calibration samples, and setting our voltage scans to be identical, we succeeded in [digitizing the magnetic field]. [laughter] It was not the most brilliant idea, but it was fun, and we did it, and we improved on it, and we presented probably a poster at ASMS [American Society for Mass Spectrometry]. I think you were with me when we invented poster sessions in ASMS.

GRAYSON: Oh, my.

FUTRELL: Yes.

GRAYSON: Back then.

FUTRELL: Way back then. So anyhow, we were doing [many] things. Among several things that we proposed to the funding agencies that they decided they would not fund was a triple quadrupole mass spectrometer, [as a platform for investigating] photo-ionization of ions. We were going to mass select an ion, put it in the intermediate quadrupole, and photo dissociate it, and then the third quadrupole was going to tell us what we had done. It was another tandem mass spectrometer that we were [creating]. And we asked for money, and in their wisdom or lack thereof, we didn't get it [...].

GRAYSON: Where did you go to ask for money?

FUTRELL: I think it was the NSF, probably, that we asked for money. And, you know, it got some good reviews, but it didn't get enough outstanding reviews, etcetera. And we had, you know, significant funding anyway, so I suspect there's an element of they've got theirs, and, you know, maybe too much funding. I don't know. Speculation. [Anyhow, we were ready to abandon our project and Marvin and I described our concept and why it was not going to happen at my weekly research conference with my students and post-docs. At that point, our fortunes changed dramatically for the better. One of my first-year graduate students, Steve Vredenburg, told us his] father and uncle had a machine shop, and it turned out that they had a really good machine shop. And so, at zero cost to me and the government, the machine shop run by his father and uncle manufactured quadrupole rods for us. And I think they made twenty-four rods. They ground them, you know, sort of following my instructions. I had done a sabbatical by this time at Boulder, Colorado, at JILA [(Joint Institute for Laboratory Astrophysics). I also worked with scientists at NIST, several of whom collaborated with JILA physicists, who frequently used JILA quadrupole mass filters in their experiments]. They had their own electronics for that, and

so we got the NIST/JILA <T: 70 min> circuit diagram and some [specialized] spare parts to build our operating electronics for [our spectrometer]. So we built the [world's] first triple quadrupole [from spare parts and professional gifts], and it actually worked. And we published a paper.²⁰ We had an awful lot of noise in [our first spectra], and so our signal to noise was not great for the photo-dissociation experiment. [We determined that the “noise” came from ion reactions in the central quad that were a couple of orders of magnitude larger than our photon-induced signal. I thought we should use it for MS/MS experiments but Marvin insisted that we pursue our (his) dream of investigating photon-induced ion dissociation].

And we were putting a small photo signal on top, but we were doing lots of other things. We were also making biomolecular ions. We were working with Jim McCloskey.²¹ You remember how to spell Jim [James A.] McCloskey?

GRAYSON: [Yes].

FUTRELL: He had been persuaded to join the University of Utah. He had a nice suite of instrumentation, and we had NIH [National Institutes of Health] grants that he and I, [and Austin] Wahrhaftig—[I think] Marvin was on it as a PI. [He] certainly was key to making any of this stuff work. And it scored very high, but it wasn't funded in that go-around. And so, we, sort of, scraped by for a year doing experiments with our own resources, so to speak, and we were going to make ions [with the effluent from] from supercritical gas chromatography. This is Cal Giddings' operation. And so, very high pressure, essentially CO₂ [acts almost like a liquid solvent] in the liquid state.

GRAYSON: [Yes]. There's a phrase for that.

FUTRELL: Supercritical...

GRAYSON: [Yes], supercritical.

FUTRELL: Supercritical fluid chromatography.

GRAYSON: [Yes], chromatography. [Yes].

²⁰ M. L. Vestal and J. H. Futrell, “Photodissociation of CH₃Cl⁺ and CH₃Br⁺ in a Tandem Quadrupole Mass Spectrometer,” *Chemical Physics Letters* 28(1974): 559-561.

²¹ See James A. McCloskey, Jr., interview by Michael A. Grayson at the McCloskey home in Helotes, Texas, 19-20 March 2012 (Philadelphia: Chemical Heritage Foundation, Oral History Transcript #0702).

FUTRELL: Yes. And so that was one of the things we were going to do, use that for separating these biomolecular ions. And then we automatically have the enthalpy to evaporate [all our solutions], and so all we needed to do was to ionize the molecular ions, as if that were easy. And then there was the liquid chromatography version, where I was going to use ultrasonic waves to put in heat energy to knock all of these unpleasant solvent molecules off. I discovered accidentally that there's a company in Salt Lake City that made the sonar resonators for the [U.S.] Navy. So man, we were able to put energy in. So we were going to do that as another [vaporization and] ionization method. And then the other one is we were going to do liquid chromatography and then use a very intense laser beam to strip off the solvents as they came out of the nozzle. Those were the things that were in play that we had proposed that got very high marks from the NIH, but no money. And I think I got a small grant, sort of...I've forgotten what they call it, pioneer grant, I think, to try out [these ideas]. And so we were working on this ultrasonic excitation thing to make ions.

And in this year when we're doing those experiments, we had some successes, but we didn't get far enough to publish a comprehensive set of papers on that, and then Marvin couldn't wait any longer. He was getting job offers, and he left to go to the University of Houston. And we sort of split up the spoils, things that he'd been very much involved in, [he] took with him. And one of those was the triple quadrupole. And he would have gotten a lot more credit, I might have gotten more credit, but he would have gotten a lot more credit had he not had such exceptional success with thermospray mass spectrometry. Okay?

GRAYSON: [Yes].

FUTRELL: So, we were still very much collaborators, so he took that with him, took a lot of spare parts, electronics, all kinds of stuff. Without <T: 75 min> Marvin [in Utah], we, kind of, lost interest [in several topics]. [I would also say that] McCloskey was a good collaborator, provided Marvin was in the loop, [and a friend, but not such an active collaborator with me] .

GRAYSON: Ah, I see.

FUTRELL: [You see,] Jim McCloskey [...] believed in store bought instruments, and so in real emergencies, when he had a machine that was working, we had to get a paper for ASMS or something, more than once he would loan me one of his instruments, and I'd find something that you could do better, and I would announce with great pleasure, "I've increased your sensitivity by a power of ten," or something [like that], and I'd walk away feeling good. He would thank me for it, and then he would tell his technician or student, "Go get that circuit out of here. Get it back the way it was and drive on."

And so, you know, the McLafferty partnership—sorry, misspoke, of course. McCloskey. McLafferty is not that way at all. McCloskey partnership to do biomedical mass spectrometry [pretty much] evaporated. He and Marvin worked together for sort of the completion of that grant, and the machine was installed in McCloskey's lab. I continued to be involved in it. The thing that I didn't agree to—was disappointed by—is that [...] key postdoc, Calvin Blakley, who was willing to do almost anything that Marvin and I thought could be done. He'd give it a very serious try, and he was good enough that he was successful more often than not. It was heartbreaking when he told me he was going to Marvin. I talked to him last week. He has a few photographs that he sent me for the interview. And he was Marvin's right hand man at University of Houston. And, you know, he said that was exciting. When Marvin left, it wasn't nearly as much fun, but he [remained in Houston]. And he is retired, of course, a number of years ago, and he's enjoying life, so he's enjoying life more than he did the last fifteen years of his career.

Anyhow, he was a key part of the team as well, to make all these things work. And I went down to visit Marvin, see what was going on, kick the tires, so to speak, when they had declared victory [on the laser evaporation project]. It was working. And what was supposed to work is that you have these—the separation going on, and then at the very tip [...] the [crossed] intense laser beam vaporizes the solvent molecules. You choose the laser wavelengths so the solvent absorbs. That was what the research grant called for. That was the theme.

Well, how do you see this intense laser? I think it was a CO₂ laser, and I'm not sure anymore. You can't see it. It's invisible. The way they track the laser is they brought it up to the tip, is that they welded wire sticking into the vacuum chamber, and you would burn [wires] off as you got closer and closer to the right position, okay? Well, you know, we hadn't thought about that in writing the grant, and [that was a] problem. That was their solution. And they were showing it to me, but the wires were all burned off by now. And so, they were actually hitting the tip. They now knew they had the laser in the right spot when the tip was glowing cherry red, okay? So I said, "*You are not* doing laser dissociation of the solvent. [You are heating the tip without touching it.]"

GRAYSON: No.

FUTRELL: Thus was born thermospray, okay? And Marvin benefited a lot from that, exploited it, came up with a number of creative ways other than lasers to heat that. The most creative that I ever saw delivered to McCloskey and then replaced was [using an] oxygen and hydrogen torch. A very hot torch inside the vacuum system heating the tip [...] and [applying high wattage] electrical heat was, you know, the heart of the commercial version that eventually emerged. Except for John [B.] Fenn and except for electrospray, that would be...

GRAYSON: The way it went.

FUTRELL: ... a much more famous way of ionizing things. <T: 80 min> Because now we're finally understanding any way of stripping solvent molecules off will generate ions, just as we said, kind of, in our proposal. It's not ionizing them. It's stripping off the solvent without changing the charge states and destroying the molecules. [This was the critical feature,] and so we were on the verge of an important discovery, and, you know, if the NIH had come through, who knows?

GRAYSON: Yes.

FUTRELL: Who knows? But anyhow, that did not work. But there were other things that came along. Agent Orange. I remember that was a different military conflict.

GRAYSON: Yes.

FUTRELL: And still around as an environmental contaminant in some places. Quite a number of my graduate students have made careers of telling people where Agent Orange is.

GRAYSON: Really?

FUTRELL: Or other interesting environmental contaminants. By doing analytical chemistry. But after [Agent Orange contamination] was discovered, at MIT, I believe, maybe Harvard was also involved in the team, there was a problem. The detection limit was very close to the toxic limit, the LD50, the limit at which...

GRAYSON: Oh, [yes]. Great.

FUTRELL: ...half the animals died. By the time you could detect it, it was too late already. There was a rush on to involve the EPA [Environmental Protection Agency]. And I was well-known to the EPA, because...in a different context, I'd been involved in the federal advisory apparatus. I chaired the Technical Advisory Committee for the Senate on Public Works, when the Environmental Protection Agency was formed, I think in 1970. Thereabouts.

GRAYSON: I think so.

FUTRELL: And I was involved in giving them technical advice, you know, for a couple of years before that happened. They started flying me around in first class to interesting parts of the world.

GRAYSON: That's nice.

FUTRELL: And it was nice. It was extremely interesting to do that. We had high level meetings with Senators I got to know.

GRAYSON: This is still while you were at Utah?

FUTRELL: [Yes], still at Utah. At Utah they call me their political scientist, because I was off doing this kind of thing. And John Baldeschwieler was the other end of the street in the [Richard M.] Nixon administration, and he ended up being Presidential Science Advisor for a short term [Office of Science and Technology Deputy Director], when I was at the other end of Pennsylvania Avenue. And it was a source of some consternation and total amazement that he and I would go to lunch and talk about science. [laughter] "How can you do this? This is the enemy?" I said, "No, he's not. He's a Republican, that's all." John helped me to get answers very quickly to a number of interesting, vexing questions, and so on. And so, EPA got started, and, you know, in the original legislature, it was to have its own research labs patterned sort of after NIST, because again, understanding what is a pollutant in the environment is not easy, and discovering what it is that's causing what problem, and so on. It was a source of [great] disappointment to me that it evolved into more of a regulatory agency over time.

But anyhow, it was exciting to be involved in starting that. And so, I was a [...] known quantity [in] EPA [circles] when this problem came up, and so they invited me and several other people, one of whom was Tom [Thomas O.] Tiernan, [my former Wright-Patterson colleague] who had in the meantime become a professor at Wright State University. He had succeeded in taking all the toys he inherited from me across the street to the Wright State University campus that adjoined Wright-Patterson Air Force Base. And so he was an important person in [our analytical challenge] And Dow Chemical was [the] lead industrial laboratory [collaborating in this quest]. And so the challenge was to increase the sensitivity by a factor of a thousand.

GRAYSON: For?

FUTRELL: For <T: 85 min> detecting TCDD [2,3,7,8-Tetrachlorodibenzo-p-dioxin]. Okay? Because then you'd be well below the toxic range, and you could detect it at low levels, detect it in the environment, all kinds of things.

GRAYSON: [Yes]. You didn't want to detect it as it was killing you.

FUTRELL: No. No. You could probably do that, but not of interest. So anyhow, with all the games we had played with mass spectrometry, it's no problem. You put in some optics to squeeze your ion beam, and we did it on the MS30. We actually scanned the electric sector, and we could do it fast enough with modern electronics that the instrument wouldn't realize that you were sweeping the sector. We could scan over the definitive experiment...that is, they would actually synthesize for us the labeled molecule. So, it's labeled with C-13. I think it may have been labeled with oxygen as well. It may have been double labeled, but it was C-13 [labelled, for sure]. And so you could see the characteristic chlorine isotopes, and then you could see them shifted for the isotopic one. The final experiment to prove you were successful was quite straightforward, but to get there, you had to increase the sensitivity. And so, we knew various tricks for putting in optics, and we knew that we could sweep it fast, and therefore we could look at the—at the isotopes and determine all this had happened when the gas chromatograph peak had come out. And so everything was happening in real time. And we succeeded in doing that.

Along the course of, in the course of the way, we had to learn about extracting dioxin from unpleasant samples and things like that, and so I had labs that were under lock and key, and postdocs only working in there, so no one would be exposed, except me and them, and hopefully not fatally exposed. Obviously not in my case. And so, every time we made progress, we found out that Dow already knew that. That was a pattern for some period of time. These people were good. They knew the mass spectrometry very well.

But then the big leap to increase the sensitivity once we had the sample selection they didn't know, and we succeeded in doing that. And then I was invited to DC to provide testimony in the Senate showing the first sample of TCDD in the belly fat of a Vietnam veteran, and so that was a well-attended [special session]. And I was asked to leave the original records. You've never seen that publication, because the original records vanished. The program officer in charge of the project disappeared, as [was reassigned] elsewhere. And the records I'd been required to leave with him got lost, and my funding was cut to zero. Just coincidence. Just coincidence.

But anyhow, I got even with the EPA. I felt good about our success in doing that. And I decided I would never send them a research grant again, and I've maintained that to this very day.

GRAYSON: Well, you know...

FUTRELL: Anyhow, there were several other things that we did. I got sort of involved/intrigued by some let's say practical side experiments, and got involved in the NSF-

funded center at Utah called the Flammability Research Center. With this drop-off in funding, drop-off in support for students, [and since] I had a dual appointment in engineering as well as chemistry, I moved to [University of Utah] Research Park to be head of the analytical part of this NSF-funded center to do fire toxicology.

GRAYSON: And this is all in Utah?

FUTRELL: All in Utah. And so the logic behind that is that people were fighting fires as if nothing had changed in home environments, and <T: 90 min> industrial environments, and so on. And so the advent of plastics, let's say plastics especially, all kinds of things would be generated in a fire that didn't exist in the handbooks of how you fight fire. If it's only wood and brick and mortar and those kinds of things, ventilating and so on is a good answer, but the [new built environment] concept was find out what's really there, and we got involved in mock experiments and so on. NIST was part of this, and so they had whole rooms that they set a fire with all kinds of things and then...and so on. The university-supported labs were far smaller. They had pyrolysis boxes and things like that. We got into pyrolysis mass spectrometry and learned—relearned, I guess is a better word—some of the radiation chemistry [approaches] to understand what's going on. GCMS was sort of the order of the day for doing that, and systems were now computerized. There were, I think, four centers in the US. I don't remember where the others were, but I will never forget the first meeting where we were showing our wares, what we had done and what we had learned, and so on. Of course, the computer would give you a probability [for assigning GC-MS peaks,] and so it would say, I don't know, 80 percent probability, whatever it is, and 40 percent, and so on. Most of our colleagues came from more of an engineering background. We had medical school people and toxicologists, medical persons, myself handling the analytical part of the operation. And so we were approaching it from many different [disciplines]. [One of the engineering dominated teams] had maybe four peaks in the chromatogram labeled as the same compound, and they simply added them up and put them into the [summary] table, reporting their discoveries. [laughter] Excuse me? No, you can't do that. That's not right.

Well, we told them capillary columns would be better, and so, you know, did all kinds of things that complicated their lives and kept us in the lead with some of those things. We did a key experiment for NASA in terms of a plastic that was going to be a lining of...I think, the space shuttle. I'm not sure. But certainly something that was going to be sent into space. And they sent it to us to examine what happened in the case of a fire, because by this time, we had had fires, okay?

GRAYSON: Oh, [yes].

FUTRELL: And we had cooked people in plastics, and so on. So, anyhow, our approach more or less was to have a chamber in which we controlled the temperature and pyrolyzed stuff, and

we have rats in an animal model that were inhaling the fumes from this. We had little tubes and masks on them, so they got dosed with whatever was in there. And then we were sucking off, samples, and doing analytical chemistry on another piece of whatever's going on. Anyhow, one of three mice had an absolutely characteristic brain wave. He was having a grand mal seizure.

GRAYSON: Oh, my.

FUTRELL: Okay? Well, find out what that is, okay? So, we actually did that. We did a GCMS experiment with a mouse as a parallel detector hooked to an EKG...

GRAYSON: This was to coordinate his seizure with whatever was coming...

FUTRELL: [Yes], whatever was coming off.

GRAYSON: ...out of the...wow.

FUTRELL: Sure. And we nailed it. I don't remember the compound anymore, but it was...we certainly saved anyone who was exposed to that, by that being ripped out and deleted as a potential plastic. And we [provided the medical research community with a means for inducing grand mal seizures in animal experiments]. So anyhow, there were interesting analytical kinds of things that we did [...].

GRAYSON: Serendipitous.

FUTRELL: And I got involved in artificial heart projects, and other things...[Utah's] artificial eye [project]. So, <T: 95 min> all kinds of experiments where a little bit of knowledge of physics, and chemistry, and mass spectrometry can significantly affect biomedical [...] experiments. And so, you know, [with] a dual appointment, license to wear a gown and walk through some of those rooms. I changed the protocol on laser lung surgery after they ignited a patient in the sixth experiment. [My] simulation with liver, and oxygen, [and the same laser the surgeons were using.] I had ignition success every time with my crude manipulation of the surgical probe. So that never entered the clinical practice. [...]

GRAYSON: So, this is in addition to your appointment in the chemistry department?

FUTRELL: Yes.

GRAYSON: So you had this dual situation where you had a...okay.

FUTRELL: Yes. Sure. So I had then chemistry, medicine, and engineering appointments.

GRAYSON: Wow.

FUTRELL: And my lab was no longer on campus. And I decided to sort of go back to my roots and go back to doing more fundamental experiments, collision-induced dissociation, this time to understand from a very fundamental viewpoint how it works, and to do it for larger molecules. And that's where Anil [K.] Shukla comes into the picture, because I tried unsuccessfully to hire him twice as a postdoc. [...] And so, I succeeded in hiring him as a postdoc to come to the University of Utah and help me reestablish my research on the main campus back in the Department of Chemistry.

GRAYSON: Wow. So, you kind of drifted off into...

FUTRELL: Yes. I had.

GRAYSON: ...another universe.

FUTRELL: I had. And when I went there, they were hiring so many people, they were planning to expand into Research Park, where my research labs were located, but they never did, at least in terms of chemistry, and so I was an isolated example there. And so, I insisted in coming back into the main chemistry building and back into the wing physical chemists were located, and so on. I was sort of getting back into that and getting research grants to build a new mass spectrometer, having a double focusing first-stage instrument to then collide in a molecular beam sense with larger molecules, and anything that we chose, actually, to look at the collision-induced dynamics, what are the scattering angles, what are the products, what are their translational energies, and so on. So, a very fundamental study of collision-induced dynamics of the MSMS tandem mass spectrometry experiment. We were going to use everything we had learned.

I left out the story of cross-beam experiments, and [that] Marvin left behind the [cross-beam apparatus designed as part of his thesis research. This was a major advance in technology for ion reactions, dynamics studies, incorporating high pressure ion sources, supersonic neutral

beams, and high resolution ion kinetic energy analysis of products. It was an excellent apparatus for its day, but interest had now shifted to higher mass ions. <T: 100 min>

GRAYSON: Right. Where “high” was proteins?

FUTRELL: No, it wasn’t that high yet. It was hundreds or so molecular weight.

GRAYSON: That’s the problem with high molecular weight. How high is high.

FUTRELL: [Yes], it has variable definition. We started out doing the electron impact ionization and so on, and within a few years we had to move up to electrospray and all of that stuff. But Anil Shukla was the key person who joined me, and we did the design, construction, all of that of this next generation tandem mass spectrometry at the University of Utah. [Anil is a good friend and the most patient scientist I know. He was the key person who was responsible for the detailed construction and testing of our new toy. He also supervised my students while I was going through a difficult divorce. This trauma, and some dissatisfaction with giving up my medical school and engineering appointments made me vulnerable to job offers elsewhere, culminating in my decision to move to the University of Delaware.]

[I want to emphasize that I was not unhappy in any way about Utah’s Department of Chemistry. I had and still have very positive memories of the place where I truly learned to be a professor, and I am very glad to report that] Utah tried to keep me. To their enormous credit, they offered me the Eyring Chair [Henry Eyring Presidential Chair in Chemistry], which they would have created to keep me there. But enough people, younger people had been hired, I had been involved in hiring a goodly number of them, that were totally qualified to be department chair, and I was ready to do something like this. [...] I was ready to do that, and Delaware turned out to be [my choice to serve as department head].

And so, moved across the country. Several interesting experiences. I took my first round of Chinese students with me and developed a connection with China that proved interesting later on. Moved lock, stock, and barrel across the country. We were going to move in a caravan. I guess we had two moving trucks and four cars who were driving together across the country, because the agreement we had with the University, that the moving truck could load everything, load over the weekend, fell apart. The university police would not let us [take] a truckload of equipment from the university. I had to call university vice presidents and get them released. It took me three or four hours after my students, other people, had left. We never met each other until <T: 105 min> we got to Delaware. I got there first, and I’d picked up two speeding tickets crossing the country, trying to catch up with them. And one of the moving trucks turned over on the Pennsylvania Turnpike and destroyed the tandem mass spectrometer that we had built. Fully insured, [and we worked out an insurance settlement], but then how do you value something that’s home built? And so on. [It was not an auspicious beginning.]

GRAYSON: [Yes]. And worked...you know.

FUTRELL: And worked, and all of this stuff. And so, it was a serious delay of getting research going again.

GRAYSON: So, what year would this be?

FUTRELL: Let me see. Nineteen eighty-six is when I accepted the job, and so it set this thing in motion. I showed up in September of 1987. Nineteen eighty-seven. There were all sorts of things I discovered about the University of Delaware that were new. I had discovered, you know, they were supposed to take my stuff to a loading dock. There was no loading dock. They didn't have a place to receive heavy equipment, do the kinds of things a modern university has to do. I had negotiated as part of my agreement to go there that the number one building priority for the university campus was a new building for chemistry, and so I thought that meant there would be a new building for chemistry. [laughter] I got there, I discovered that not only was there no loading dock, but there were no doors wide enough to bring in...[and that I had to help raise money to build a new building with the modern features that were needed.]

GRAYSON: Oh, wow.

FUTRELL: ...stuff that needed to be done. And so, we had to knock out walls and all kinds of stuff to get the instruments that were not broken installed and started up again. So a long, difficult story to restart the research and...

GRAYSON: It would have a year, years, year?

FUTRELL: It was about two years.

GRAYSON: Two years?

FUTRELL: About two years to get everything up and going again. And Anil Shukla was absolutely key to helping make that possible, actually. [...] The university is a private school, just as Cornell is. It's a state-assisted private university.

GRAYSON: State-assisted?

FUTRELL: Yes. That's the formal classification. And that [implied]...approved for a new chemistry building meant you got to meet the development officer and raise the money to build a new building for the chemistry department.

GRAYSON: Were you helpful?

FUTRELL: [That was one of my assignments. And with a lot of help from the University president, and support from the DuPont Company and family], that was a successful enterprise. I also had, as part of my dowry, I had [...] five million dollars for the endowment that I could use for starter grants and things like this to hire new faculty and make things happen. I got six slots to build up the technical services, to build up the machine shop, electronics shop, glass shop, and add a computer support facility. [...] And I think I had six faculty slots that I could recruit towards, and there were six persons who were assistant—non-tenured assistant professors. This became twelve faculty slots as things played out. And so anyhow, I had sort of the basics to build a department.

GRAYSON: What kind of department did they have prior to your arrival?

FUTRELL: [They had some very and some not-so-good faculty.] Well, I told the department [in our first planning session,] that this was their third try to become a distinguished research university. When Delaware was really set up in the sort of immediate—I'll say wartime and post-wartime period—as a graduate university, DuPont Company sent senior people to be chairman of chemistry and of chemical engineering, and they were sort of funded to launch these departments. And chemical engineering was extremely successful, one of the top [ten departments].

GRAYSON: And this was because DuPont, you know owned Delaware...

FUTRELL: Yes. Sure.

GRAYSON: ...and they wanted...

FUTRELL: It was DuPont country.

GRAYSON: ...to make it.

FUTRELL: And wanted to make it happen. But the person they sent knew <T: 110 min> the kind of people that you had to hire and so on and so forth, and the chemistry [head] sort of feathered his own nest and hired people who wanted to do similar things. You know, I'm exaggerating. I don't know why he went wrong. But anyhow, [chemical engineering had] a very successful trajectory; [and chemistry did not]. And so, it was...it was not a failure, but it was not hugely successful. It was one that had some good people, some really good people. And that was essentially the story after I got there. They then hired another person coming in with very good academic credentials, and so you do it all over again and see if it works. And I'm not sure why, [but in addition to some]. I had some very, very good people, they kept several who shouldn't have been kept. And, you know, again, to go back to Dean Kenneth Pitzer, when I let be known I was going to University of Delaware, he invited me to come visit him in Berkeley and have a chat about how you do this.

And we had had a few conversations before, but this time it was very serious. He gave me names of people. He said, "These are first class people, and so they should have more say in how the department is run than others. And so you've got to be absolutely brutal, make it perfectly clear what your expectations are, and if they meet those expectations, great. If they fail to meet those expectations, well, it didn't work, guys. Sorry it didn't work."

And so that's absolutely what you have to do to either build or preserve a [...] first-class research institution, whether it be a university or some other kind. And so I knew what had to be done. And the fact that Burnaby Munson was there, the fact that Douglas [P.] Ridge was there, meant mass spectrometry already had a very significant footprint.²² And so they didn't need me to be in the laboratory all the time coaching students who needed help and so on. There were resource people immediately available to talk to about mass spectrometry. Neither of them were funded very well. I imagined that I could help with that, and that turned out to be true. And the labs needed to be re-equipped and so on, and so we did all of those things.

GRAYSON: Munson had a connection to the Humble Oil and Refining outfit, didn't he?

FUTRELL: Sure.

GRAYSON: Were you there with him at the same time?

²² See Burnaby Munson, interview by Michael A. Grayson at the University of Delaware, Newark, Delaware, 9 April 2010 (Philadelphia: Chemical Heritage Foundation, Oral History Transcript # 0688).

FUTRELL: No.

GRAYSON: You missed him?

FUTRELL: No. He was the person hired to replace me.

GRAYSON: Ah, okay.

FUTRELL: And he got to do the experiments that I didn't get to do. [laughter] And so I met him as my replacement, and so on. And when Burnaby came to the University of Delaware, his first graduate student—this I thought was quite interesting—John Michnowicz, [...] had an industrial career, [at] Hewlett-Packard [...]. When he was a graduate student, he called up to get my advice on building a better chemical ionization source, so working with the patent owner and founder of chemical ionization, I treasured that phone call, and I was happy to help out with it. And they had invited me a couple of times to give talks in University of Delaware and so on. And so, there's several positive aspects of going there [and I was well known to some of their faculty].

And it turned out to be a wonderful move in all kinds of dimensions. Among other things, I met Anne [Graham] at a faculty meeting, my wife, whom you know.²³ And it really was love at first sight and has never changed. I immediately got over my nasty divorce. I wasn't [in great shape financially and recovered from] part of our story is she picked me up out of the [trash bin. But I had a reasonable income and a brand new house, and so Anne saw possibilities for hanging her art, and she did.

Anyhow, [Delaware] was a wonderful career because my being first in line in the development office meant I had license to raise money. And so, I had to talk to <T: 115 min> people who had money, and so I got connected with them. Had to talk to federal agencies about matching grants and all kinds of things for instrumentation, etcetera. I got to testify to the General Assembly on the need for buildings and so on.

GRAYSON: Is this for the state?

²³ Professor of Art Anne Krohn Graham is a distinguished artist whose metal work is found in the Smithsonian Cooper-Hewitt Design Museum in New York City and in many corporate and private collections worldwide.

FUTRELL: For the state. And we were successful [in funding and constructing] the Lammot duPont building. One of the rules I learned in the development office, you probably know this, but if you're going to ask for money, you have to give money, and so if you go to the University of Delaware [and visit] the Lammot duPont Laboratory, the first one named for Lammot duPont. Lammot duPont was the [second generation DuPont family member] who moved the DuPont company from [black powder] to nitroglycerin and modern explosives. He had studied with, guess who, Alfred Nobel. Bringing that technology to the DuPont Company was done by Lammot duPont. It seemed to me that kicking the DuPont Company in the posterior to modernize how they did explosives was a good thing. And so, we were the first to honor him by the Lammot de Pont Laboratory [that we intended to change how chemistry was practiced at the University of Delaware]. That also brought some sizeable checks, one of which came to me personally for two million dollars. And after a few microseconds of thought, I decided to endorse it to the University and [move] on. [laughter] You know, I could have wiped out personal debts very quickly, but it would not have been a good thing, and my father [taught me to be honest in all things].

Anyhow, it was very successful fund-raise exercise. Got to know people. And so if you come to the entryway of this, you'll find a list of donors, Dr. and Ms. Jean Futrell, in the bronze plaque in the front of the duPont Laboratory. And if you go to the oldest...let's see, no, you go to the art museum, there's a big brick hallway, walkway, huge brick walkway leading to the university museum. And the bricks have names of donors, and so you find Jean H. Futrell and Anne Krohn Graham bricks, if you look very carefully. They're still there. We checked it out [not long ago].

GRAYSON: Oh, good.

FUTRELL: Bricks are still in place. So, you got to give some money before you ask for money. And so we got involved in lots and lots of people, influential sources. I became conversant with all the funding agencies. By this time, I'd already been president of the American Society for Mass Spectrometry. You were one of my officers, Mike.

GRAYSON: I guess so.

FUTRELL: I think so.

GRAYSON: Everything is...that two-year term, and of course, you guys got stretched over this huge period.

FUTRELL: [Yes]. Mine was a six-year term. I'm almost certain that we [worked together] in one of those [venues].

GRAYSON: I've got the data back at the ranch.

FUTRELL: Either that or you [ran] the poster sessions, when I came up with that creation [to accommodate a rapidly growing Society].

And in those days, we had the Henry Rosenstocks and the big shots do all the posters to get people to recognize what an important medium it is for communication. My [more recent] professional society thing I got involved with was the Council for Chemical Research, [whose] department heads chemistry or chemical engineering [for] academic members. [Director] of chemical research or close equivalent, if you represent a government laboratory, or an industrial laboratory. And so it's the industry, government, university coalition, and teaming; [...] a very, very powerful approach to [solving major problems]. And if I look back at all the toys I made, I realize that if I had partnered with an instrument company on any number—well, not all, but some—some versions of these toys that I made for doing my fundamental research studies, [...] would have become [commercial products]. At least *I* think so. So that's what I tell myself, that they would have. And my PhD <T: 120 min> student who's so distinguished, Richard [D.] Smith, has more patents, more industry collaborations, than any other scientist in Battelle worldwide. [That's something he did and I never did.] Worldwide Battelle [employs about twenty thousand] holding scientists and engineers now [...] huge organization internationally, [about three thousand] here at PNNL [Pacific Northwest National Laboratory].

GRAYSON: [...] PNNL is what, Pacific Northwest National Lab?

FUTRELL: Yes. Pacific Northwest National Laboratory.

GRAYSON: Okay. And so you're saying...well, I don't want to get ahead of the story but you're...there's about [two] thousand people in that environment [of professional staff]?

FUTRELL: [Yes, total PNNL staffing now approaches five thousand]. So it's very large, and a part of PNNL that we come to shortly is my going there as the first [Director of PNNL's National User Facility], the Environmental Molecular Sciences Laboratory. [...]

GRAYSON: You probably need...[yes]. Take a water break.

[END OF AUDIO, FILE 1.2]

GRAYSON: One of the things that's appearing obvious to me is that as you're moving along in your career, you were actually getting a little bit further from the science. I mean, you almost sound more like a political animal. [laughter]

FUTRELL: At Delaware.... I shouldn't have told you they called me a political scientist. [laughter]

GRAYSON: But, I mean, you know, you're spending a lot more of your career, your time, and doing things that aren't directly related to bench science.

FUTRELL: Yes. That's a fair assessment. And I just mentioned, I think, the Council for Chemical Research and what it is, and so on. I actually got involved with lots of advisory committees. I was on the National Academy committee that developed [Technology] Vision 2020 [The U.S. Chemical Industry], I think it is, sort of, predicting what would happen technically and business sense, everything else, by 2020. Those were interesting exercises. The Council for Chemical Research is something I really believed in, that some kind of partnership involving industry and National Laboratories, federal laboratories, and the universities, and that turned out to be a many-year engagement. For some time, I chaired the Government Relations Committee after...well, I started out in government relations, then became the elected chair of the Council for Chemical Research, and then chair of the governing board after that.

So we tried to work with the American Chemical Society and with American Institute of Chemical Engineers in particular, to make the case for chemical sciences, for funding for the chemical sciences, for *increased* funding for chemical sciences, and so on. And we found that by going together to Capitol Hill to have people provide testimony and illustrations on how these things have paid off in terms of jobs or infrastructure developments and things of that sort, was very useful to say the financial prosperity of a state or a region or some significant slice of the United States. And we also found, no surprise really, that if we brought in industrial people to testify about the value of funding universities, they had more credibility than sending university people [...] okay?

GRAYSON: Right.

FUTRELL: And analogously, having academic people testify in favor of funding for let's say federal laboratories, National Laboratories, and so on, and talk about how these different sectors can work to the mutual benefit of science and to technology. And then making the case [for] science, technology jobs, prosperity, money, the usual argument, but making it as convincing a

case as possible, and with illustrations whenever you can. And so that's something that I was involved in for a number of years. I even miss it a little bit, this trek to Capitol Hill—

GRAYSON: Well, [Yes], it's [...] it seems to me that the individuals that are a part of the Council should be able to establish a fair degree of credibility with...I mean, you're talking about the directors of laboratories...

FUTRELL: Sure.

GRAYSON: ...in both government and industrial settings. And then department chairs and...

FUTRELL: Sure.

GRAYSON: ...and so it's a very...well, self- or already vetted group of people who by virtue of their careers, where they are in their careers...

FUTRELL: That's right.

GRAYSON: ...can speak authoritatively to people who were in positions of power.

FUTRELL: That's right. And the distinction, Mike, just to make a point, the distinction between CCR and a professional society...

GRAYSON: Like the ACS is like that...

FUTRELL: Let me [rephrase where I am going with this though]. One of the things I had to do to provide credibility and direction to the Department of Chemistry and Biochemistry to build its future at Delaware was to connect what we were doing with a national plan. And interestingly enough, there was a report called the Pimentel Report, developed by George Pimentel, a name that had come up previously.²⁴ When George was Science Advisor, I had my first opportunity to dine in the White House.

²⁴ The Pimentel Report is the commonplace name of the following report: Committee to Survey Opportunities in the Chemical Sciences, and Board on Chemical Sciences and Technology, and Commission on Physical Sciences,

GRAYSON: That's nice.

FUTRELL: Had a few others. The food's not that good. [laughter] But it's still a privilege, [a distinct] privilege to do that. And he had developed with a number of other science leaders throughout the country a plan for the future of the chemical sciences that you've heard about. It's called the Pimentel Report. I used the Pimentel Report as the framework for developing a strategic plan for the chemistry and biochemistry department at the University of Delaware, and actually invited some of the program officers from federal agencies to come speak to us at a retreat that we had of the faculty. Completely unknown to me, there's a person named W. [William] R. Wiley, who was the director of PNNL, who was using the Pimentel Report to develop a plan for the W. R. Wiley Environmental Molecular Sciences Laboratory [at PNNL].

GRAYSON: Oh, wow.

FUTRELL: Didn't have his name on it at the time. You have to die to get your name attached to a laboratory, so I'm not looking forward to any laboratory...

GRAYSON: Named after you.

FUTRELL: ...named after me. And I never got to know Bill Wiley, Dr. Wiley, but he was also a southerner. He was black, which is interesting. He was the first, and I think he may be the only, black American to be director of an Office of Science National Laboratory. And he was born and grew up in Mississippi. I got to know his widow, because he died before I came here, but I got to know [...] about him through her. But anyhow, he had a much harder path to his success, you know, [on] leaving the South, than I did, I'm quite sure of that. And he got his degree I believe at WSU [Washington State University], his PhD degree. [...]

GRAYSON: That's Washington State?

FUTRELL: Washington State University. So anyhow, he was using the Pimentel Report, and his concept of the environmental molecular sciences, to move PNNL away from its origins as a tech service support group to the Hanford cleanup operation, to a National Laboratory. Required

Mathematics, and Resources, and National Research Council. *Opportunities in Chemistry: Today and Tomorrow*, (Washington, D.C.: National Academy Press, 1987).

a real fundamental science core, and it should be a fundamental core that is somehow related to the local...let's say the legacy environmental challenge that followed the Hanford reactors that generated all the plutonium during the Cold War period. And so the cleanup of the Hanford site and [preserving] Columbia River to its [...] pristine condition [by] ensuring it never gets contaminated is a huge [challenge].

And so environment...clearly, some very nasty environmental problems, understanding the biological component of that biological problem, which really defines the Department of <T: 10 min> Energy role in biological sciences. [It is nothing short of miraculous] that extremophiles, as biological single-cell bacteria, [go to such lengths to extract energy from hostile environments]. A bacterium that changes the valance state of plutonium and uses this energy transfer of electrons for its own energy source, growth, and prosperity has actually saved mankind from plutonium entering the Columbia River, and downriver. In the haste to build the reactors [...] and they built single shell tanks to store the waste, thinking they would build one reactor, not five. So anyhow, in the wartime situation they did things—as you have to, make decisions with limited information. And although the pioneers, let's say Enrico Fermi and Glenn Seaborg, for example, who were involved in the design of the first production reactor here at the Hanford site, predicted that the life of the steel tanks would be fifteen years. They were conservative. [The tanks] lasted longer. But they absolutely predicted that you would have to solve the disposal of the Hanford reactor waste in a few years, and there were enough years to do it, if they had really focused on that. Instead, because of world politics, they focused on building more reactors. And this time having a more secure way to dispose of the waste, but nevertheless, the Hanford site, because the tanks leaked and got into the soil, the existence of this single cell bacterium called deinococcus radiodurans [fortuitously changed plutonium to a higher valance insoluble state]. [laughter] [...] My daughter, who speaks Latin, knows immediately why the bug was named that.²⁵ It thrives in a radioactive environment that would be a lethal dose to us in about fifteen minutes. And this bug survives, replicates itself, and continues to change the valance state of plutonium.

GRAYSON: And by virtue of that change...

FUTRELL: Changes the valance state, becomes insoluble, and so it doesn't get washed into the Columbia River.

GRAYSON: It gets locked up where it's at.

FUTRELL: Right. That's right.

²⁵ Professor of History Alison Futrell, University of Arizona, Tucson.

GRAYSON: Wow.

FUTRELL: And it has now been excavated and moved well up the hill, in what we presume is a safe location, secure location, till they finally decide what to do with it.

So anyhow, [Bill Wiley] conceptualized the Environmental Molecular Sciences Laboratory as having some major environmental component which involved biological sciences as part of his plan, and involved energy, involved the environment, involved the molecular [scale investigation of these and other science issues of great importance to DOE and the nation]. And going well beyond nuclear reactors and so on for the sort of applications of Department of Energy, which by this time was charged with [stewarding a broad range of energy and environmental issues]. What are the energy resources of the United States, and how to [use them safely and efficiently], and so on and so forth.

GRAYSON: This is the Wiley vision?

FUTRELL: The Wiley vision. And he used the Pimentel Report to develop the plan for that laboratory, and then I was using it as part of my strategic plan for the chemistry/biochemistry department, and to guide our hiring. What kinds of people do we hire, and so on, to make sure that we were lined up with the national strategy. And also take them down and get them acquainted with the funding agencies and so on and what their expectations <T: 15 min> are, essentially to get new academics as quick as possible, understand the funding climate and how to access it. Very important, as you know [...].

GRAYSON: [Yes]. Money [is important].

FUTRELL: Exactly. But I learned over the course of years that you have to explain very precisely and very carefully your stewardship of those funds and why it might be advantageous to the country to do [something]. And so anyhow, just sheer accident, and we were equipping a three-building complex, modernizing the old buildings and creating a new building.

GRAYSON: This is at Delaware?

FUTRELL: At Delaware. And equipping them with state of the art instrumentation. Lots of mass spectrometers, of course, by this time. I was addicted to them and had gone away from my aversion when I started my career. So, mass spectrometry was a key role. You won't be surprised, probably, that my own mass spectrometry laboratory was called the duPont Lab

inside the duPont Building, because duPont funding had helped to equip that laboratory. And so on.

And I had worked the federal agencies to convince them that our department was on the right track, and so an investment in Delaware was an investment in the future. All kinds of stories how I learned how you get departmental resources. I was the principal investigator for all major equipment proposals, and I found out what succeeds and what fails, and so on. And so by sitting on the boards that make decisions nationwide, you learn how they operate. And that helped me guide the preparation of proposals and so on. So everything...the bottom line is it worked. My goal, I had to have the University agree on the goal, was to bring chemistry to the same percentage level in terms of federal funding as chemical engineering. And so, you know, initially they wanted me to make it like chemical engineering. I said, "Excuse me. I'm a chemical engineer. Let me explain that there are a very small number of accredited chemical engineering departments compared to chemistry, and so we've got to talk in percentages to understand what the rational goal would be. If you ask me how to become a top five department in chemistry, we have to start by annihilating about twenty-five departments, and nobody's going to allow that to happen. And so we have to define our terms."

[We agreed on percentile ranks as a goal and we succeeded in my term of office—11 years—in reaching this goal.] In the meantime, through Dick Smith, my former student, I learned about the Wiley Laboratory. There were, let's see, probably twenty-five card-carrying leaders in the mass spec community who came to give lectures. Tell people at PNNL what the exciting science in mass spectrometry was, as if they didn't know. And we had one fateful meeting, I remember perfectly, occurred in Seattle [Washington]. We had a two-day workshop. The senior citizen, elder statesman [for our group of experts advising PNNL] was Fred McLafferty. We all gave invited talks, and it was fun. So the charge to us is suppose there's infinite sums of money available, what kind of laboratory would you create? What would the instrumentation be?

And we had people from instrument companies there to listen and tell us their ideas. We had people who made magnets, okay, tell us how big a magnet could you make, and so on and so forth. And so it was great fun, okay, just to pontificate and, you know, argue, debate with your colleagues. What would be the most important science, and how would you do it, and so on and so forth. And so there was a pretty significant shopping list that was developed. I do know some of the details of what my little subgroup recommended.

But <T: 20 min> then after all this was over, we had been fed and entertained for a couple of days, the outline of the workshop report was agreed upon, and we went away and left the PNNL people to put it together. We [...] had a celebration dinner at a nice restaurant in Seattle, and after dinner, in the conversation and so on, Fred stood up and rapped on his glass and said to us, "Well, ladies—" we had a few—"and gentlemen, I'm sure we all agree this was absolute fun. We've enjoyed this, and we'll all go back to our home sites now having had fun. I'd just like a show of hands. Who among you believes anything will come of this?" [laughter] Okay? Nobody raised their hand. Okay?

GRAYSON: They're afraid they'd get called on if they did.

FUTRELL: We were unanimous. We had had fun, we had made our recommendations, we did not expect it to happen. But you know what? It did! And so thanks to Bill Wiley and thanks to Battelle pushing it and knowing how to do this, it got defined as a National User Facility emphasizing the molecular sciences.

GRAYSON: This is PNNL?

FUTRELL: This is EMSL [Environmental Molecular Sciences Laboratory]. This is what became the Wiley Environmental Molecular Sciences.

GRAYSON: Oh, okay.

FUTRELL: So this is a wholly-owned part of the Department of Energy housed on the campus of PNNL, okay? And so, when we go to the campus tomorrow, I'll show you the federal flag that flies at the EMSL Building where my office is. [...]EMSL has a separate reporting line as a National User Facility to PNNL, which is [the parent DOE] National Laboratory. They both report to [Office of Biological and Environmental Research [OBER], DOE's] Office of Science. And so generally speaking, biological sciences, environmental sciences, molecular sciences broadly, report to this part of DOE. But the funding for this laboratory comes from all parts of the Department of Energy [as well as other federal and private agencies]. [phone ringing]

GRAYSON: That's okay. We can just put the hold on that. Where's the hold?

[END OF AUDIO, FILE 1.3]

FUTRELL: So anyhow, the funding of National Laboratories is complicated. If the Office of Science is responsible for one that has a significant slice of fundamental sciences in its mission, the distinction of PNNL compared to other Office of Science National Laboratories, Lawrence Berkeley [National Laboratory] Lab, Argonne, Oak Ridge [National Laboratory], et cetera, is that the central theme here is [more focused on] chemical and materials sciences [along with substantial emphasis on engineering, applied science and national security]. The Oak Ridge central theme is materials sciences. The others are much more physics in their orientation than this one. This always involved, has a substantial chemical engineering, a larger chemistry component, and some physics...and atmospheric sciences, actually, is a component of this

laboratory. And then the National User Facility, the EMSL, was really the brainchild of Bill Wiley that he pushed for. And so all the people coming in and giving advice were telling him which of these different things, all of which are in the Pimentel Report, are the key technical areas, technological components, of that kind of user facility.

And so mass spectrometry became part of it, and EMSL held for, I think it was eight years, the record of having the highest field, highest resolution FTICR [Fourier transform ion cyclotron resonance], even though the Magnet Lab, Alan [G.] Marshall's lab, has now bypassed and...well, actually, no. We have a bigger one now. [laughter] But it's very temporary. But for a number of years...Alan Marshall was at this meeting I mentioned, and he took home our advice to move to 15 tesla. But Dick Smith was more conservative. We recommended 15. He settled for 12, and achieved 11.5, which I rounded up to 12 when I came here as director. That's the rule, you know. It's a mathematical rule. [laughter] So, 12 tesla held the world record for a long time. And 15 tesla was Alan's goal, and he achieved it at 14.5, which he illegally rounded too. [laughter] And the state of the art commercially now is 15, as you probably know.

So at any rate, mass spectrometry, nuclear magnetic resonance, electron microscopes of all flavors, theoretical computing, these all became components of the environmental molecular sciences. Biology, but not a huge component of the laboratory. There were probably seven or eight people, something like that have biology as a discipline. But it was almost the same things that we had carved out at University of Delaware.

And so in coming here initially, as a savant—dare I say that? - along with Fred McLafferty and others, Alan Marshall, being part of the group that gave advice on what should be done, and many other people gave advice, and they chose some parts of that that they would actually do, and pursued that course. When mass spectrometry was included, Dick Smith asked me to chair the Mass Spectrometry Advisory Committee for the Environmental Molecular Sciences Laboratory, and so I came in and actually began to understand more of what they were actually doing. And we were doing well enough that I was invited to be a member of the larger advisory committee, Strategic Advisory Committee, to the group that was developing [detailed objectives for the] Environmental Molecular Sciences Lab.

So anyhow, I had a successful run as department chair. We had moved up, and so we now were listed, you know, on the upper part of the page in *C&E News* when they reported annual funding, across the country, and had hired, I guess with retirements, about fifteen faculty. And, you know, renewed the old buildings <T: 5 min> as well as a new building, equipped them, you know. Things were going pretty well. And then I returned to teaching and research, and I was very well funded to do teaching and research, but I had a lot of time on my hands compared to being a department chair. [laughter] I wasn't unhappy. Life was good. But I was old enough that it seemed to me I should think about, you know, beginning to sort of think about retiring, and so I decided I would not take any more graduate students, and so I would play out the funding in my present grants, might try for more funding and postdocs, or might not. And the university had a very favorable [staged retirement] plan that [encouraged senior faculty to reduce their workload over three years. It was a business-motivated plan] to get rid of higher-paid faculty, you could take it by thirds, reduce your teaching involvement, they would [pay

your full] salary up until year three, and then plunk, you're gone, but you can draw your retirement salary starting at that point, and so on. So that seemed kind of interesting.

And I was in that frame of mind when I got the surprise phone call, "Would you be interested, would you please consider putting your name in [as a candidate for EMSL Director]?" I knew a national search was being launched. I'd seen the job description. I'd actually helped write it. [laughter] It was a little odd in the sense that it said the director should have an active research program, so he or she would know what it's like to do research in a National Laboratory setting. It's certainly going to be different from a university, if you recruit someone from a university, and certainly different from industry, if you recruit from industry, and so on. Anyhow, [...] was a member of the committee that put together the job description and they said, "Do you want to see it?" "No, I don't need to see [...] the job description." "Would you be interested?" "I don't think so, but I will talk to my wife, because it's a two-body problem. If she's not interested, then I'm not interested, and so I'll speak to her, and call you tomorrow."

Well, timing is everything. Anne was not having a happy day at work, and so when she came home late at night—parenthetically, I should say that in the chemistry department I taught during reasonable hours of the day, and in the art department, to get enough students in her classes, she taught at night. It was my job to pack her dinner, and she would teach till 11:00 p.m. or something like that and come home, by which time I was pretty sleepy, and then I would [go to work] at a normal hour and she would go [...] later in the day, so our work schedules were out of synch. Our vacation schedules were totally in synch, and we toured the world, sometimes with an art theme, sometimes with a science theme. But by this time, I had professional colleagues all across the globe, and so life was really good.

But I had promised to speak to Anne, and she had had a bad day, and she said, "Yes, let's get out of here." And so I called back and said, "Well, guess what? You have a deal, and I'm willing to be considered in this total pool of people that are going to be interviewed."

GRAYSON: This was 19...

FUTRELL: [It was late spring] 1998. This was...

GRAYSON: So you'd been a decade or so at Delaware, to get your...

FUTRELL: Sure. So I was there from '87 to '99, actually. That's part of the story, because [in] 1998 they were actively searching [for the first director of the fully operational EMSL facility]. They'd been declared operational a year earlier or something like that, but they were still moving stuff in and they hadn't really started to recruit users very much, so they were open for

business, but [just barely]. And they wanted this person to come in time to report to the Secretary of Energy in 1998.

At the time my name went on the list, there were thirty-five <T: 10 min> or so people, and I didn't take it very seriously. We came out and, you know, [and this] small town didn't impress Anne very much, so, you know, she wasn't excited about it. The second day they took her to Walla Walla [Washington], which is the old historic town nearby with a liberal arts college and people that she knew were on the art faculty. She had a wonderful time [...]. So her second day was good, and mine was not as good.

We came back. We didn't think it was serious. The list kept getting shorter and shorter and shorter, and my name was still there. We came out a number of times, and at some point in time [we need to tell our kids what we were thinking about. Anne's] daughter is a chemistry major from University of California, San Diego. My daughter is a history major from the University of California, Berkeley. And so, I think we were down to five on the list, something like that. We decided it was time to consult with our kids, tell them that we were considering something. Because of this crossover, Anne, you know, third generation artist, somehow her daughter was a chemistry major, and so the other side of her brain communicated very well with my brain. And my daughter was making a crossover in the other direction. And this was very useful. We called my daughter to tell her that perhaps something might come of this. And she said, "What? Let me talk to Mom." And so she was dead set against it, you know. She says, "Give up a tenured full professorship, distinguished career in art, to go nowhere and be nothing? Why would you do that?" And I was listening on the extension. I said, "Wait a minute. Whose genetic daughter are you? Let's straighten this out."

And so we crossed over and called the other daughter, who by this time was teaching in Tower Hill School on the East Coast, and we had actually brought her with us on one of the interview trips. She helped us pick out this house. She said, "Mom, this is your house." And I said, "No, there's no way you can afford it. I don't have the job and they won't sell it." [laughter] "So forget that." But she said, "It's your kind of house." Well, she was right, of course. And so we talked to the chemistry person, and she said, "Are you kidding? Haven't you seen Dad's eyes sparkle? Don't you know what he thinks about when he's spent all these years building up the department that someone else now runs, and he has one that's ten times bigger and a staff of two hundred that he can work with? So of course you should think seriously about that." So since the advice was orthogonal, you know, it was a big victory on our part. [laughter] It was okay with our immediate family that we could continue to take a look at this [new opportunity]. So anyhow, we finally came out, because the list got down to three. One was an industry person. He actually worked for DuPont [somewhere in] the Life Sciences Division of DuPont, a very well-established industrial scientist. One was an environmental woman scientist who now is a major federal laboratory head. [...] And me. You know, up to that point, we had probably thought the industry guy would get it. So the woman is being kept in the game till the last moment. I'm the token old person that's kept in the game. But now we were down to three, and so it was clear something serious was [about] to happen.

So, Anne and I came out expecting to be offered the job, and so we spent a three-day visit, and we toured all the <T: 15 min> interesting sites, and wineries, and everything they could show us. We were entertained royally. And they didn't quite get to the point of offering the position. We were distraught, disturbed, disappointed, and Anne kind of lost her temper. They were saying goodbye to us, and [our host said], "Hope you enjoyed the visit." She said, "No. We wasted all these visits to this stupid city, [laughter] and nothing happened, so you will never see us again." [laughter]

GRAYSON: [Yes].

FUTRELL: And I said, "Thank you. Goodbye." Well, anyhow, our real estate person we had talked to who had this house for us was going to lose a substantial commission, and he was, you know, working the company. But they already knew how upset we were, and disappointed, so to speak. When we were getting ready to leave for the airport the next day, the Associate Director of the lab responsible for filling the position called while I was taking a shower and wanted to talk to me, and Anne said, "No, he's busy taking a shower, and we don't have a lot of time." So he said, "Please let me talk to him as soon as he finishes his shower." I finished the shower, and I returned his call, and he said, "I want to talk to you." And I said, "Really, we don't have time. We have to go to the airport, so why don't you call me next week?" He said, "No, I'm downstairs." [laughter] "I'm waiting for you to come to the lobby." So my job offer was waiting to take with me to the airport. And so he said, "How does it look to you?" And I said, "I'll call you next week." We were kind of huffy in our reaction to all of this.

And then I told him next week a couple of things. I said, "Okay. Clauses A, B, C, and D are fine. E and F, G, need to be changed, etcetera." And so then it looked like a good offer. "And so it's the kind of offer I think I might accept, but you waited too late, so school has started, and so the new deal is that I can't come this year. We have to teach school, and so the earliest date that I can come would be January of next year. But we're planning our first cruise vacation in January, which is a Delaware holiday, and so I cannot report until February 1999, as the earliest date. Those are the terms. If you want to offer it to somebody else, I totally understand. Go to the second person on your list, or maybe I am the second. I don't know. But anyhow, that's what has to be changed." And he says, "Fine, no problem." [laughter] "[The] Secretary of Energy is coming in two weeks' time. Can you join us?" I said, "School. Didn't you hear what I said? School has started. I've given a lecture already. So it's not as easy as it was during the summer."

GRAYSON: [Yes].

FUTRELL: He said, "Well, we really want you here." And I said, "Okay, I can probably get someone to teach school for me." Of course you can. That's the way academics work.

GRAYSON: [Yes].

FUTRELL: Trade teaching back and forth. And so I knew I could go out there, and so I did. And I got to meet the high-ranking people from Battelle, highest-ranking people from Department of Energy, and so on, and they wanted to introduce me as the new director. And I said, “No, [we] haven’t worked this out.” So I agreed that they could introduce me as the person who had been selected by the review process to become the Director of the Wiley Environmental Molecular Sciences Laboratory. That’s the standing I had in talking to people for that very revealing visit [to witness] the show-and-tell [exercise] that you have to do in a National Laboratory. <T: 20 min>

I went back and I made a couple of trips to Washington, D.C., to talk to [PNNL’s] steward in the Department of Energy, because I wanted to be absolutely sure that my understanding, based on PNNL, matched up with his understanding of what [EMSL should strive for]. And that was okay. I sort of asked the person who was the official steward, “What are your expectations for this laboratory, and for the director?” He said, “Pretty simple. Show me what it’s good for.” I said, “Is that it?” He said, “Well, I can give you a strategic plan and any number of documents, but what I want you to do is to demonstrate to me what it’s good for in terms of the Department of Energy mission.” And I said, “Okay. Let me be more precise, because there’s a mission statement for your part of the Department of Energy, and there’s one for Basic Energy Sciences, which is the part that is supporting my own research, which is a different mission statement, and I can get five. Are you talking about your mission statement, or all five mission statements, or the higher level DOE mission statement?” And he said yes. [laughter] I said, “Let me restate what I understand.”

GRAYSON: Not helping you a whole lot.

FUTRELL: No, he’s helping me immensely. I said, “I want to make sure we understand each other. You want me to help this laboratory demonstrate that it is making major contributions within any of the mission spaces that have been assigned to the Department of Energy.” He said, “Yes.” I said, “Done.” That’s an easy assignment, because you don’t have to be specifically pointed at this or that or the other. And we had a first class set of scientists. It was the most advanced set of instrumentation existing anywhere for doing research in the molecular sciences, and so on, and so it was a chance to operate at a different level, but sort of doing the kinds of things that I’d been doing for a while. And so unknown to me, I’d been training for that job. [laughter]

GRAYSON: But I have a [...] you don’t normally have access to these people in D.C. I mean, most people don’t normally have access to them.

FUTRELL: No. No.

GRAYSON: But you—you were in a position or felt comfortable, I guess, what, through the Council for Chemical Research and through other avenues...

FUTRELL: Sure.

GRAYSON: ...you knew you could talk to this guy, and he said...

FUTRELL: Yes. Exactly.

GRAYSON: ...they entertained your concern?

FUTRELL: Yes. He understood that perfectly, and it was news to me, you know, that you could have that kind of thing. And we were successful. Officially from February 1999 to October 2002 I was the director in residence, but I actually was appointed in '98. And so, after I said yes, I accepted, they started sending me to Washington again and again and again. I actually went pretty much every week for my final semester at Delaware, I was making a trip to Washington to talk to somebody about something. Of course, I was paid a consulting fee for this, and followed all the University rules. And then I officially retired from the University at the end of that academic year. And the University was very good to us. There were all kinds of things that I had sort of picked up as a department chair helping to bring in money to the University, higher-ed people, and so on. Going through two or three university presidents, and, you know, constancy of change is something that I had gotten used to, that you don't normally think of. As a university faculty member, you don't, because within your surroundings, it's a very stable environment. But at my level, it was not stable, and it's certainly not stable at national labs, and <T: 25 min> so there are changes every few years.

That's how I came to PNNL, and I had just extraordinary staff, [and they had] extraordinary instrumentation. And so, it was our job to demonstrate value, and we succeeded in doing that. The Basic Energy Sciences part of the Office of Science [stewards] national labs at the Lawrence Berkeley Lab, for example, at Argonne, at Oak Ridge, Brookhaven, those examples had long history. We were the runt of the litter and the newcomer to the enterprise, and so the way that they operate, I had learned a little bit about because my own research had been supported by DOE, Basic Energy Sciences, and they had agreed to increase the size [of my grant] because the charge-out rate is significantly higher if you pay the overheads of a national lab.

Part of the agreement is I would move my DOE active research grant from Delaware to Richland whenever the laboratories were ready here. I also encountered the safety standards and everything else at National Laboratories that are distinctly different from university labs, and so I had to start over. To execute, DOE had to recreate all of the instrumentation that was critical to my BES grant when I came here. And so, that involved two major instrument design and building experiments, which cost several millions of dollars, actually, by the time we were through with it, because as I learned years ago [at Wright-Patterson's Aerospace Research Laboratory], it was much more expensive to do something at a National Laboratory than it is at other places—using union labor for everything, all of the craft practices, having all the checks and balances for what you do, and working in a really risk-averse environment.

Anyhow, it all adds to the cost of doing business. But a combination of Department of Energy and Battelle Corporate funded all the expenses of setting up my laboratory, so I [could] move the research program from an academic setting here. And so we moved it out, and we gave my last set of students a choice. You can finish in location A or location B. I turned over my other federal grants to other persons to finish up, and so forth. And we made the sort of abrupt step into life in different circles.

One of the other differences I encountered is in a National Laboratory the time constant is much shorter. In other words, the time you have to demonstrate your good idea actually works is probably a factor of three to five shorter than it is at a university. Universities are hooked to training students, graduate students, so by definition you're working with people who are not total professionals, and by definition, in National Labs you are working with people who are total professionals, and state of the art machine shops, and support facilities, and all of that. The funding is higher, but the time to demonstrate that your idea is good or bad is much shorter, and then the sort of funding strategies also depend on headquarters developing, through workshops and so on and so on, how things are actually done. So, those were things that were new, [that] I had to learn, and so on.

Anyhow, it's been a very interesting run. At the end of my term, I became a Battelle Fellow, and Battelle Fellow is an interesting title. It's a corporate title, so it's awarded by Battelle corporate, based on recommendation of a lab director or maybe a set of lab directors and associate lab directors at one of the Battelle-operated National Laboratories. So that would be the Office of Science labs, actually Brookhaven, Oak Ridge, ourselves, and Lawrence Livermore—no, <T: 30 min> Lawrence Livermore is a weapons lab. Sorry about that. It'd be Brookhaven, Oak Ridge, and PNNL, are the Battelle-operated Office of Science National Labs. The Idaho [National Laboratory] lab is operated by Battelle for their nuclear reactor part of Department of Energy. And then the weapons labs, Livermore involves a Battelle partnership in its operation. So Battelle is the largest single not-for-profit operator of Department of Energy labs...also true, I believe, in the Department of Defense. There are, I believe, three major labs operated by Battelle for the Department of Defense in this country, and then there are major labs in England and in Italy, smaller labs, Germany, Switzerland, France, Japan, Korea, China, so on. So Battelle is a worldwide R&D organization.

Well, I believe there are six Battelle Fellows, and so it was my honor to become one of them. And then I had the challenge to develop a statement of what a Battelle Fellow is and does.

GRAYSON: You were made one and you...

FUTRELL: [Yes], so I had to do this.

GRAYSON: ...had to explain what you were.

FUTRELL: [Yes], it had to be formalized, okay? Richard Smith is the other Battelle Fellow that you would know here, and I can name the others, but you probably wouldn't know them. There are four at PNNL. We have more here than anywhere else. And that's where the job description was written. So for the personnel [department], now called HR, there had to be a description of Battelle Fellow and what he or she does.

So I wrote it up, and my wife thought, there's no chance that'll be approved. And I said, "You're right. That's just the negotiation position." But it essentially says you will do more or less what you want to do, so you'll work out an annual contract with, in my case, PNNL, what it is you would like to do, and then at the end of the year you'd be held accountable. And if you can demonstrate that you have added value, whatever, that you could go for a second year. And if you screw up, you have one year to get it sorted out and do better.

But anyhow, that's essentially it. A Battelle Fellow has the liberty to write his or her own job description in terms of some details, what are your goals for the year, what do you expect to achieve, and so on. You know, I developed goals. When I stopped being Director of the Environmental Molecular Sciences Laboratory, having done it for three years, I guess, a little over three years, we had doubled our funding. We had a staff [...] approaching four hundred, something like that, and had doubled the funding that existed when I came. And the heaviest lift I had to do is to get the Department of Energy to understand that computers are supplies. They're *not* capital equipment. [laughter]

GRAYSON: Yes. That has changed.

FUTRELL: Yes. And so we started out ordering I think the third largest computer that had ever been constructed, and it was pretty much off the list of the top twenty by the time that I came. I've heard rumors that it was sold on eBay for one hundred thousand dollars or something like that. And so it represented a twenty-million-dollar investment that should best be thought of as an office supply, because within five years it's going to be obsolete. [laughter]

GRAYSON: [Yes].

FUTRELL: And so, convincing people that they had to treat it that way...

GRAYSON: As a capital expense, but it's a...

FUTRELL: [Yes]. Sure. It's a capital expense. You have to reinvest on sort of a five or six year cycle. The procedure for going through that, and how you do it, and so on, the workshop that establishes the mission need, and then the state of the art of computer development, projecting <T: 35 min> where it will be three years out, and then...

GRAYSON: Forget that.

FUTRELL: ...what it takes to get there, and so on, and so on, and so on. So anyhow, as part of that, the computer wing of the building had to increase [in size by about a factor of five].

GRAYSON: Wow.

FUTRELL: And the energy bill to run it had to go up by twenty-five, or something like that. And so, you know, that's a business expense, but it's a painful one. I guess, in a non-trivial sense, that this was one of my major achievements as Director. The other one is getting the lab on the map, and so we, you know, sent people to conferences, and we wrote papers, we developed [journal] covers. By the end of my term, we had a poster where we could show twenty or so covers, including a couple of mine, that [was later posted] in DOE headquarters. If they walked down the hallway, ah, this is what this user facility does, and this is some of the evidence of scientific impact, and so on. And so we had to gear up the user program and [show how it operated].

And so anyhow, there have been many changes over time, the sort of mission approach of EMSL has changed. It's changed in directions that I'm not totally comfortable with, and would not have persuaded me to come here as director, if those had been the guidelines at the time I was recruited. But I came here, bam, [to] a new facility, [to] show us what it's good for. And so we did that. We did it very successfully. I actually ended up as Battelle Fellow in the largest office at PNNL, because I had to remove myself from EMSL and do something else, and, you know, finding a—you know, a suitable office for a Battelle Fellow, I selected one that had been vacated, not knowing that it had once been Bill Wiley's office. [laughter] Bill Wiley, when he was developing the plans, occupied that office and was three times the size of typical

executive office. Even after you subtract the conference room and some of the other adjoining spaces for showing slides, etcetera, it was still by square feet larger than the sitting lab director's office, and about twenty percent bigger than my office as director of EMSL. But I had plenty of space to [show] Anne's artwork, all of the things that I'd brought over. And then [I] decided that I would work directly for the [PNNL] Director and try to help define the scientific missions of PNNL. And so, I started doing that, and so I went to visit other National Laboratories, became reacquainted with what they were doing, and so on. And then of course I was replaced, and [when] they found a real staff person that would be in place for a number of years to work on that.

And so I, you know, continued to do my own research, invested a little more energy in that probably for several years, and ended up in the course of a reorganization being involved in [a different part of PNNL]. In the reorganization, the funded scientists within EMSL, that is, people that I had sort of encouraged and helped to do the science, the increased funding, they got [their work on journal] covers, were reassigned to the Fundamental and Computational Sciences Research Directorate, and then the EMSL User Facility became a much smaller laboratory.

The people that I worked with most closely, including my own research group, [including] Julia Laskin, are part of the Fundamental and Computational Sciences Directorate. And when the office of Chief Scientist for that Directorate was created, I became the first one, and [this helped] to sort of <T: 40 min> define the future directions for people who were closest to me, and their research interests, and so on [that transferred over from EMSL [...]]. So that was easy and fun and so on. [More recently a senior scientist from Lawrence Livermore Laboratory has replaced me as Chief Scientist and Julia has replaced me as Research Lead for Mass Spectrometry.] I am a courtesy member of her research group, but she runs it. She does a great job at doing that. [...]

But I did have an interesting job of writing a strategic plan for the laboratory. [...] A credible strategic plan had to be ready for the new administration when President [Barack H.] Obama was elected [and immediately named Nobel Laureate Steven Chu (and Director of the Lawrence Berkeley Laboratory) to become the next Secretary of Energy. I think not since Glenn Seaborg led the Atomic Energy Commission under President John F. Kennedy, had anyone with] real knowledge of Department of Energy Science [programs] been named as Secretary of Energy. Typically, for political or business or other reasons, someone gets selected eventually to fill out the cabinet. So, this strategic plan that you have to develop is [traditionally] a throwaway, is never implemented, because by the time a new person is in charge and understands Department of Energy well enough to make any executive decisions, a new one has to be submitted. And [this becomes] the significant [strategic] plan. And so I was in charge of helping out with the throwaway plan. Well, [Steven] Chu was appointed [as Secretary of Energy Designate just one week after President Obama was elected in November].. And so, he was not Secretary of Energy, but he had an office in Washington, DC, and the Department as a courtesy extended him a certain number of staff to help him do his work. And indeed, everybody else in terms of political appointees came in with science credentials no one has seen in recent history.

GRAYSON: Oh, wow.

FUTRELL: It was a completely unexpected thing.

GRAYSON: There were science people running a science operation.

FUTRELL: [Yes]. [And my throwaway strategic plan became a real one and actually was a good plan. The people whom I arm-twisted to help did a really good job. Some proof of this is that PNNL got the largest chunk of funding from the Recovery Act of any of the Office of Science laboratories. And so I'll show you the new buildings on our campus tomorrow, and EMSL has two new wings on it, and has bought sixty or seventy million dollars' worth of new toys and so on. And so it's like it was when I came. It's now fully equipped with state of the art instrumentation, and so that's kind of where things are at the moment.

GRAYSON: So you've kind of retired, but you haven't retired?

FUTRELL: That's right. So I have [retired but] not retired. I continue to be involved with let's say federal agencies and National Academy committees and so on, giving advice, writing reports, whether or not they're ever acted on [...]. And one that I [...] coauthored with Alan Marshall...let me see. I guess, it was six years ago now, something like that. <T: 45 min> [...] The workshop report [on next generation high field FTICR] was written, reviewed, published, smiled upon. But funding was not [available]. Alan used that as a core for a research proposal to the NSF, and again, it was reviewed, but [a project] projected to cost nearly twenty million dollars, was something that couldn't be funded at the National Science Foundation. Similarly, we made noises within the Department of Energy, and sort of a postscript to this strategic plan was a recommendation that the Department of Energy in collaboration with the Magnet Lab develop such a FTICR spectrometer to operate at twenty-one tesla.

GRAYSON: Wow.

FUTRELL: And so that was the proposal. And of course, when you submit a strategic plan in the DOE system, the DOE has to approve it, or it goes nowhere. And so they looked at this and said, "Well, okay, twenty million dollars, and maybe running around one or two million dollars a year, so it's not out of the question that you can develop this in ten, so we'll approve this to occur over a twelve-year time period." And so, that was part of the thing that went in and was approved.

But the new decision-makers at the Department of Energy said, “You can’t [advance] leading technology, whatever it is, if you’re going to take twelve years to develop it.”

GRAYSON: No, that’s...

FUTRELL: “So submit a new plan to do it in three years or forget it.” Well, all right. We can do that. In the meantime, in the Recovery Act [American Recovery and Reinvestment Act of 2009] testimony before Congress, the Director of the National Science Foundation says, “We have reviewed and recommended projects we cannot fund, and so we have shovel-ready projects that are ready to go.”²⁶ One of those was Alan Marshall’s project, and I don’t know of any other project in NSF history approved by the Director before the division acted on it. But the Chemistry Division accepted the challenge and approved it, and so Alan got Recovery Act funding.

We did not. It looked as if we might, because of course we said, “Yes, we can do it in three years. Give us the money.” And they said, “Hold on a minute. We don’t simply award things on the basis of approved projects that involve major construction.” So I said, “What construction? We have a lab. We can dump out the instruments there. There’s no construction. We have space to accommodate it.” But what they mean is we review this as if it were a construction project, and so you have to have two levels of technical review, and validation, and everything else. And so, it delayed our start by about 15 months compared to **<T: 50 min>** Alan Marshall before our project was approved. And it had to be funded out of the regular budget rather than Recovery Act funding. And so the difference is the money had to be spent within a short timeframe, and the NSF defines money as spent when it’s given to the university, when the university has control. And so, their money was spent over a much shorter time frame than ours, because ours is reallocated every year. We have a much more cumbersome project.

But anyhow, the upshot of all this is that we are collaborators with Alan Marshall in the creation of the world’s first twenty-one tesla FTICR spectrometers. Now because they had money first and been working on it, we’ve learned an awful lot, being engaged with Alan, and what he is doing. I say for the record, it’s a total collaboration, that we share information and ideas and best practices, and in their case, some results of their research, as they built up a prototype spectrometer to test various concepts, but we’re operating independently in terms of our ideas and how to do it. And beginning in January, we’ll be testing these ideas in our prototype mass spectrometer. So in the meantime, as Battelle Fellow, my prime assignment to myself and to PNNL is to understand the physics of the challenge of building this twenty-one tesla FTICR spectrometer as best as one possibly can, and see to it that we adopt best practices and give us the best possible shot at actually making this happen. It’s a formidable challenge.

²⁶ Pub.L. 111–5, 123 Stat. 115, H.R. 1, enacted February 17, 2009

I can point to various lines of evidence to support this, but let me just say this, that it's a tighter magnetic bottle than people have—have tackled before, in terms of inserting ions into it. The fact that you want to use more of the homogeneous field, because you want to have higher dynamic range. That means you want to have more ions in there by at least a factor of ten than commercial FTICRs. And so the challenge of containing a larger number of ions, and doing [this] without them interfering unduly with each other [is a challenge].

I mentioned earlier the ion mirror effect. And this is one of the limitations with mass resolution, because it exerts a drag any time you come close, and we can define in terms of the physics what that means, to any conductor, while it's inside the intense magnetic field. So we're outside the magnetic field, so we have to worry about these in terms of every conductor, every lens element that's involved, to a degree that's not bothered people in previous [designs].

Also, if you have [ions with up to] one hundred charges [with] the same mass-to-charge ratio, then these Coulomb forces overpower the other forces, even in intense magnetic fields. And so this coupling of the individual particles together in effect forms a non-neutral plasma, so the ions are rotating around their center line in the magnet field, and the magnetic field is no longer the ion cyclotron resonance formula. It's different from that by the rotational frequency of the plasma. [These theoretical constraints] are known to exist, have been occasionally demonstrated a few times in my own lab, but never published. But anyhow, as you squeeze the ions tighter and tighter in the higher magnetic field, this happens sooner and sooner. And so it's a **<T: 55 min>** significant part of the challenge. [We will be] doing a strange form of plasma physics in ion cyclotron resonance at the higher magnetic fields. We also have to operate at much higher vacuum.

Actually, [...] for at least a paper I've written, but not published. [These plasma clouds are essentially bullet proof with respect to CID; all except head-on collisions will introduce minuscule shifts in plasma frequencies. These hard-core collisions [whose dynamics] I studied for years and [more recently] Jack Beauchamp [...] from Caltech, has [extended to] hard-core collisions for larger peptides, these collisions with multiple atoms [actually] knock them out of the [molecular ion]. These [collisions] change the identity of the ion, not by the RRKM kind of mechanisms or things we've discussed previously. It's just a shattering [result that tears] them out of the molecule that they're in, is going to be a limiting case to the transient that you can observe, and therefore to the resolving power that can be achieved. And so, you have to have to have additional stages of differential pumping, at least one, almost certainly two, and possibly three. Interesting scientific problem...

GRAYSON: [Yes], well, the problem is that it's physics.

FUTRELL: [Yes], it is.

GRAYSON: But, I mean, you're a chemical engineer.

FUTRELL: That's right. [laughter] But I took extra courses, and I know whom to call if I need help. You put these additional stages, pumping stages, you have to use ion funnels developed by my former student, Dick Smith. I cite [here] the paper we wrote together doing the theory of ion funnels.²⁷ The physics of what you're doing in ion funnels is [seriously compounded by your moving] your electrospray or [other means of ionizing your target molecules] further away from a magnet that's gotten bigger. And the differential pumping requirements have gotten significantly higher. And so whether you like it or not, you have created a [lousy] time-of-flight mass spectrometer, okay? What you have to do to [address this issue is] what used to be called velocity focusing, okay? So, you have to have the slow ones and the fast ones arrive in the important area at the same time. Anyhow, everything new is also old. This is going back to the early days, and we talked about...

GRAYSON: Time-lag focusing.

FUTRELL: ...time-of-flight—yes. Time-lag focusing in a different context comes back again. So because I was there, I understand time-lag focusing. Because I was there, I have actually designed optics that will do that. And there are wonderful new technologies, kind of materials you can get are extraordinary.

One other that's orders of magnitude more serious for this new spectrometer than was ever appreciated before is the absolute alignment. And so maintaining absolute integrity from whatever your starting point is for shooting the ions down the line so that they are on line and not off axis, so that they interact with the magnetic field or any of the electric fields, including RF fields. So, all existing commercial systems are off the table. None of them will work. So anyhow, in a strange sense that's the kind of problem that I've really enjoyed thinking about, over and over again. Where's Marvin? I need him?

GRAYSON: Right. [laughter] He's trying to build a super time-of-flight mass spectrometer.

FUTRELL: Oh, [Yes]. I'm so glad he didn't present that invited talk <T: 60 min> until we got the money to do the other thing. [laughter]

GRAYSON: Might have changed the direction of things.

²⁷ Kim, Taeman, Aleksey V. Tolmachev, Richard Harkewicz, David C. Prior, Gordon Anderson, Harold R. Udseth, Richard D. Smith, Thomas H. Bailey, Sergey Rakov, and Jean H. Futrell. "Design and implementation of a new electrodynamic ion funnel." *Analytical chemistry* 72, no. 10 (2000): 2247-2255.

FUTRELL: It'd be fun if Marvin Vestal succeeded in building the highest resolution time-of-flight ever while I succeed, my team, building the lowest resolution ever. [laughter]

GRAYSON: As a front end to your FT.

FUTRELL: As a front end to the FT. That'd be a wonderful irony, if it worked out that way.

GRAYSON: This was an irony of Al Nier. You know, he came out...he and Johnson came up with the Nier-Johnson design, but he actually had a space probe or, I think, a high altitude probe for which he abandoned that design and used the Mattauch-Herzog design.

FUTRELL: Yes. Right. [laughter]

GRAYSON: And so he knew that that would work better than the one that he had done for himself, and that was interesting. He commented on that during the interview I did with him as kind of fun.²⁸

FUTRELL: Anyhow, the other part of my research career, to sort of pick it up again, is—is [surface collisions]. It was already clear it had to be peptides. I attended a talk that Vicki Wysocki gave in the Washington, D.C., discussion group—mass spectrometry discussion group. And at Delaware, we always took all of our graduate students down in a company car or some carpool or whatever. Any that we could get to attend that, we would always take them down for those technical sessions. And I heard her presentation of these curves for surface-induced dissociation, where the parent ion drops very quickly over a limited kinetic energy range, and then the products come up. And I saw that, and I said, “That’s not possible. That’s what a much smaller ion might do, have sharp cutoffs. Because of all the internal degrees of freedom, that can’t be correct.”

As I said, I’m always overjoyed when things that can’t be correct turn out to be correct for some reason that you absolutely don’t understand. Anyhow, I got intrigued by—by what she was talking about in surface-induced dissociation. Her PhD mentor, [R.] Graham Cooks totally deserves credit for inventing, discovering surface-induced dissociation, but that’s not correct. I discovered in the tandem mass spectrometer days, when I was learning how to steer ions and put

²⁸ See Alfred O. C. Nier, interview by Michael A. Grayson at University of Minnesota, Minneapolis, Minnesota, 7, 8, 9, and 10 April 1989 (Philadelphia: Chemical Heritage Foundation, Oral History Transcript #112).

them where I wanted. There were a lot of things they ran into in these diffuse peaks that I studiously ignored. Okay? And some years later, actually when Anil Shukla and I were building up a new tandem mass spectrometer to a much higher resolution for the ions, because we knew we were going to [move] up in molecular weight, and, you know, other bells and whistles, we rediscovered it, because all of our mass peaks turned into doublets. And we had just enough resolution in the second-stage analyzer to see that they were too broad and they had a dip in the middle. So every mass peak was a doublet. Why is that?

Well, it had to be something in the ion flight path. It almost certainly had to be at the mass resolving slit, because that's the only place you can get a doublet up and down the mass range. And sure enough, there was a mustache hair. Now we never determined whether it was his mustache or mine, but we had rediscovered [...] again surface-induced dissociation.
[laughter]

GRAYSON: Surface-induced dissociation.

FUTRELL: And we had Graham Cooks as part of our seminar series when I was at Delaware, and he was talking about some of the wonderful things that he was doing by SID, not with peptides, doing small molecules. See, we have to describe what small is. These are the big molecules I was taking about earlier. So the <T: 65 min> sort of benzene-sized and a little bit bigger, naphthalene, whatever. But not peptides. And he was showing the surface-induced dissociation in his talk. I'd introduced him. I was sitting in the front row, and I did a mean thing. Sort of doing rough energetics...for what he was doing, I calculated the center of mass for the collision process. It would be the upper limit of energy that would be transferred in a collision. I had made a living doing this with molecular beam experiments for years, so of course, it was very easy for me to do that.

So in the discussion period, after there'd been a few interesting [questions], so I said, "Well, Graham, would you like to know what you're colliding with?" And he says, "Well, I know what I'm colliding with. You know, I have this metal plate, this conductor that I'm putting in there." And I said, "No, you're not. First of all, this won't happen on a metal plate, if it's a real conductor, and absolutely clean. I can explain to you later something I learned much earlier in my career, that it's going to be neutralized. So, you know, that's not what's happening. And what you're doing is you're bouncing it off of pump oil, and so I can tell you the center of mass, and we can talk about volatility of oils and so on. And we'll do this at dinner tonight. But you're looking at a contaminated surface, and that's causing your surface-induced dissociation."

Okay. Well, we had an interesting discussion for dinner and so on. I'm sure he wasn't convinced, but I was convinced, and I set it aside.

I saw Vicki Wysocki's talk, and I said, "This can't be true, so we have to take a look at it." It was easy for me because she was at Virginia Commonwealth [University], as John Fenn was. And so it was easy for me to spend a day, just drive down and visit her, go into her lab, do

the experiment, and by golly, it was true, okay? Hmm, all right. This is very interesting. Also saw John Fenn and had a nice conversation with him about what was going on in his laboratory, and so on. And close to that point in time, Graham Cooks gave an invited—I think, a plenary lecture at an International Conference on Mass Spectrometry [meeting], and he talked about surface-induced dissociation. And he talked about the surfaces that Vicki Wysocki was using. [They were using]self-assembled monolayers on gold, [specifically gold (111)] An alkylthiol will sit down and bond to that surface, and then you have this alkyl chain that's sticking up in space. And this has the marvelous character that it's physically precisely defined pump oil, okay? And what you have to create is neither an insulator nor a conductor, but a semiconductor, okay? [Finally, if is a fluorocarbon it will not adsorb pump oil. In other words, he now had a perfect surface for SID].

So, as far as the incoming ion beam is concerned, it has to be an insulator, and so it will bounce off. But the charges that are captured, and some will be, have to be neutralized. And so they have to tunnel in or whatever they do to be neutralized by the conductor. And so Graham and his army of students had determined the chain length that was necessary to make it a semiconductor. He didn't know it [had to be] a semiconductor until I explained it to him, but [the] really precise characteristics [of this semiconductor were the key to understanding SID].

Then I guess I owe my understanding to Peter Debye. [laughter] When he wasn't talking to the janitor, took a little time to explain a few points to me, and it turned out to be useful and interesting. [So I said to myself, and to anyone else who would listen], "Okay, now we have a well-defined surface, so you can begin to do kind of experiments that I love to do to understand what's going on." And so that was our entry into surface-induced dissociation. Graham actually sent us the self-assembled monolayers. I recommended fluorine, because I wanted to bounce ions off of pseudo-teflon. I actually can tell you the reduced mass, **<T: 70 min>** and I can tell you that odd-even alternation effects have to do with the tetrahedral angle of carbon and whether the CF₃ group is sticking up orthogonal to the surface or the tetrahedral angle.

GRAYSON: Wow.

FUTRELL: Is that neat? Well, I know that because the—the beam-scattering apparatus that Shukla and I built enabled us to do some of those experiments before a funding agency lost interest in understanding those kinds of details. We had learned some very valuable things. Vicki moved. She moved to University of Arizona. [...] She had a couple of students that were two-body problems, and it was a spouse wasn't ready to finish up, and so we [co-directed their theses], and they finished up at the University of Delaware.

GRAYSON: Oh, wow.

FUTRELL: And—and I got to learn much more about peptides than I ever thought I'd be interested in learning, and having a long term collaboration with Vicki Wysocki. It was interesting to me that my daughter ended up at the same university, and so two or three times a year I've always enjoyed visiting with Vicki Wysocki, and I'm chagrined to learn that she is now at [The] Ohio State [University].

GRAYSON: Oh, my. Another move.

FUTRELL: So gee, you know, I could have stayed, you know, in Ohio, been a professor at Ohio State, instead of bumping around the country and never holding a job very long. So—so anyhow, the wonderful fact that Julia Laskin joined my research group, that she knew even, dare I say this, better than Marvin Vestal and others the nuances of absolute rate theory, that it's identical to RRKM theory, and her thesis research and all of her research for a number of years with Chava Lifshitz dealt with that, including C_{60} , and applying it to a huge molecule like that. And so Julia was the perfect person to think about moving up to peptides and approaching it from a very sound theoretical basis. And we learned, to my amazement, that we could actually use this theory to describe the majority of collision-induced dissociation for peptides up to a molecular weight of the order of one thousand. I was very surprised that this turned out to be the case.

We also learned in the course of investigating that that there were some things it could not [explain], and we discovered some [reactions] that are extremely fast. We called them shattering reactions.

GRAYSON: Shattering.

FUTRELL: And we demonstrated this experimentally at almost the same time that Bill Hase, William J. Hase, who holds the Welch Chair [Robert A. Welch Professor] at Texas Tech [University]—he's coming for dinner in a couple of weeks. I'll get to see him again. When I received the [2007] Field and Franklin Award, both Julia and Bill Hase spoke at my seminar, showing the connection and overlap of the theory [and practice for] these reactions that occur extremely rapidly, so fast that you don't have any chance for vibrational coupling with the rest of the molecule. And so we called them shattering reactions. [...]

The other thing that was demonstrated is something that Graham Cooks also introduced and gets credit for, and that's soft landing.

GRAYSON: Soft landing.

FUTRELL: Soft landing, okay? And so his idea, if he could decelerate ions as low as he could, that some of them actually land on the surface <T: 75 min> instead of doing collision-induced dissociation, and he's absolutely correct. So it was a minor part of the surface-induced dissociation project that we embarked on, and we had better deceleration lenses and so on, so we plotted curves where at the lowest energy, the only thing you saw was the ion coming in. It was bouncing off of the surface, so nothing was happening. And then you opened the lowest energy channel, highest energy channel, and so on, and march up the RRKM range of things until you get the very high energies when these very fast reactions begin to dominate what's going on.

And I had found these kinds of reactions in my beam studies of very small molecules and ions earlier on. In fact, Henry Eyring and I had discussed this. How big is big? So, if you apply your theory, sir, absolute rate theory, at what point is a molecule so big that one end doesn't know what's going on at the other end? In other words, how rapid is the transfer? It's called intramolecular vibrational relaxation. How fast is that compared to finding a low energy dissociation channel and falling apart?

Anyhow, our first attention was focused on surface-induced dissociation. We showed a number of unique properties, and one or more invited talks called it a chemist cyclotron, because you could deposit arbitrary amounts of energy. We had discovered in these specific semiconductor surfaces there's a fairly narrow energy range, and you can actually go down to low energy, and you can go up to high energy, and this window walks up. So in a single collision, you can distribute any desired amount of energy with some [...] range of energies, and that range of energies depends on how you make your semiconductor surface. You can make a soft surface and make it wide. You can make a narrow surface and it's narrow. A vapor deposited diamond is a very narrow, very hard, very robust surface...

GRAYSON: I bet.

FUTRELL: ...for doing that kind of project. And then we later turned our attention, we found these very fast reactions, they also made sense to us, made sense to Henry Eyring...

GRAYSON: This was at Utah?

FUTRELL: Well, at Utah we discussed it, and then years later in my career, after Henry Eyring's death, I did molecular beam experiments to find these very, very rapid reactions.

GRAYSON: This is at...

FUTRELL: This is at Utah primarily, and probably extended over a bit into Delaware. But it was small molecules, how fast do things occur, and compare dissociation and electronic excitation, those kinds of things. Very short time events and longer time events. So anyhow, we had found that kind of phenomena. And so, that it was lurking there was not so surprising. The fact that you could find it and it would be a fairly sharp threshold and so on were surprises to us. And that's something I, you know, years ago, I thought I might in my retirement years look into that. I still fantasize I might think about that a little later on, and I'll talk to Bill Hase about it when he comes in a couple of weeks. But that's fantasy.

I told you of things I was doing otherwise, but what I do want to say is that the soft landing area has become [the] major emphasis for the Laskin group going forward. [...] You can prepare these surfaces so the ion actually lands on an ion [...] and it's very easy to lift [ions off the surface]. [They are very stable in vacuum, but if they are exposed to air the ions disappear]. Okay?

GRAYSON: Oh, [Yes].

FUTRELL: But as long as you keep it under vacuum with the proper kind of surface, you can actually keep it there for quite a long time as an ion. And if you deposit doubly charged or triply charged, quadruply charged ions, you can look at the rate of the electron transfer process, and <T: 80 min> you can work out the kinetics of the details of how triply charged ions changed to doubly to singly to a neutral. And so this whole process that I guess I thought about and talked about with physicists at the very beginning, you can spread out in time by doing it on very special surfaces. A take-home lesson that I find amazing that we actually talked about at the University of Delaware and in workshops I was part of with theoretical chemists and so on, is that surface science has so many analogies to what you do in the gas phase and the condensed phase. [...]. And so by studying surfaces in particular ways, you can actually uncover details that tell you a lot about what's going on in bulk and is consistent with what you have established to happen in gas phase. An amazing thing, that you can actually do these experiments and learn such a wealth of details.

Let's see. I guess you could say in a weird sense Graham Cooks has always claimed mass spectrometers are the ultimate chemistry laboratory, and are capable of doing anything and everything, and I believed him, and I consider the mass spectrometer as the ultimate chemical physics laboratory, that you can do anything. And part of my work over many years, many publications, in molecular beam-scattering studies, was to demonstrate that every nuance that the molecular beam community had discovered for neutrals is also present for ions. Okay? The fact that they're charged [implies] you can migrate them around and study them in much smaller abundance than you can the neutrals. But every single aspect that has been found for neutrals has its counterpart in ion chemistry and physics. It's been a wonderful period to do all of that.

What's Graham doing now? Well, he's doing atmospheric pressure ionization, okay? He's dissecting the electrospray process to all of its parts. And he's getting invited, plenary

lectures to announce these amazing discoveries. They are truly amazing. And then when he sits down, I tell him, “No, that’s not what you’re doing. This is what’s going on.” And so I told him that he was scattering droplets, scattering invisible droplets. His first story was wrong, and so of course he’s modeled the scattering of droplets, and that is what he’s doing. And so there are actually commercial sources that allow you to find the preferred angle for scattering of invisible droplets from surfaces.

Well, EMSL bought one of those, and we actually did some experiments with it. [Graham’s story is essentially correct.] But you can dissect the whole thing further, and Julia and her coworkers are doing that, because if you’re just scattering droplets and then you just have a hose to pick them up somewhere, that’s not nearly as elegant as it is to define very precisely the region where the droplets are hitting, and the region where you’re picking them up. And so she and her students have increased the sensitivity of that kind of process, and that’s actually reported this week as one of the outstanding science achievements of PNNL.

Anyhow, I’ve been the luckiest of individuals to sort of by accident arrive at the right place at the right time...

GRAYSON: At the right time.

FUTRELL: ...and do something that was very interesting to me, and seemed to have quite a few spinoffs in other—other dimensions. It’s been fun.

GRAYSON: [Yes], it sounds like it’s been fun.

FUTRELL: Yes.

GRAYSON: It’s been fun listening about it as far as we’ve gotten. I’ve got some other issues I’d like to go over, but...

FUTRELL: You mean we’re not through?

GRAYSON: Well, we’re getting close, but I think maybe we ought to hang it up for today for sure, or maybe at least for now, and maybe...

FUTRELL: [Yes]. I think so, too.

GRAYSON: ...think about coming back...look at that collection of things and see what we've
<**T: 85 min**> covered, all that territory, and in the meantime, I'll put this guy to sleep.

[END OF AUDIO, FILE 1.4]

[END OF INTERVIEW]

INTERVIEWEE: Jean Futrell

INTERVIEWER: Michael A. Grayson

LOCATION: Pacific Northwest National Laboratory
Richland, Washington

DATE: 29 October 2012

GRAYSON: [...] So just for the record this is Mike Grayson interviewing Jean Futrell in his office at the Pacific Northwest National Laboratory on the twenty-ninth of October.

FUTRELL: I believe that's correct.

GRAYSON: Year 2012, and we're wrapping up a day and a half of fairly intense discussion between the two of us on his career and his contributions to science. What we want to do here is be a bit more general in our questioning, and I just have a half dozen short questions that we'd like to pontificate upon. And the first of the ones that I have listed here is your experience in becoming a scientist. You're the man from Dry Prong...

FUTRELL: [laughter] That's right.

GRAYSON: Did you ever envision at any early point in your life that you would end up becoming a scientist, and do you feel that where you really ended up is the right place?

FUTRELL: Well, there's no doubt I ended up in the right place, but how I got there is hard to describe.

GRAYSON: I've already got a day and a half worth of that. [laughter]

FUTRELL: We have a detailed discussion of events, semi-chronologically, of what happened. But no, I had no concept at all as a young person of becoming a scientist. You know, my image of a scientist was someone in a white coat away in a laboratory somewhere doing something. We mentioned earlier in the interview that my first kind of connection, if you please, with science as a kid was when I was in the second grade, and at Christmastime I got a chemistry set. The chemistry set that you could buy in those days is actually a common origin for many

chemists. Over different times in my career, I've discovered other people when they were growing up somehow found a chemistry set, and/or they found ways of making flames and explosions and so on. So, chemists seem to have an interest in that.

In fact, when I started my teaching career, I was about to become a professor at the University of Utah. I went back to my alma mater, my PhD institution, University of California at Berkeley, and I went to see the people who were responsible for general chemistry, the upper division chemistry people that I had met, because I wasn't required to teach because I had a fellowship for my entire graduate career, but I wanted to learn what they were doing. And so I volunteered, actually, to assist a couple of the senior professors, and also to help out in the lab, not being responsible for the lab, but kind of poking around and talking to the undergraduates who were doing chemistry at the University of California.

But having missed out on the teaching, which is typically part of a university internship career, I wanted to talk to people. I went back and talked to the faculty, to some of the TAs and so on, and lecture demonstrators, because they had this valuable asset. I recommend that highly, if you're going to teach general chemistry, have an expert to do the lecture demonstrations. Do not do it yourself. And I found that over ninety percent of the demonstrations were flames or explosions of some kind, highly exothermic reactions, and so that seems to be what catches people's attention, at least in chemistry. And in physics, there are different things, and so on, but the underlying principal driver I learned many, many years later when I took a psychological test to kind of understand myself better, and **<T: 5 min>** the strongest driving force in my makeup is curiosity. And so I think curiosity is the driving force of people who get into science, engineering, and so on. If making a lot of money is their motivation, that's probably not the right profession to think about.

But I also remember...it actually became a principle I used later as a teacher, that if you could have a graduate student get to the point where he or she makes a discovery all by themselves, and so they've actually asked a question of Mother Nature and they get the answer. They get the answer, okay? There's some very, very, very good students that couldn't take the pace in working as a graduate student with me, and I think it was because I asked them to do something that was too hard or whatever first, and they never got to the point where you yourself are the only person in the world who knows the answer to a serious question, and you've got to tell somebody.

That's another key part of being a scientist, is you have to tell somebody. Now there's a rather stale formalized way of doing that, and that's too bad in some sense. But there's a very formalized structure of communicating scientific discovery. It involves other people, your peers or sometimes senior people in the field you're just getting into, that look very carefully at what you've done, and occasionally they punch holes in it.

As I've advanced in my career, I found out that was fun, too, to punch holes in some accepted theory, idea, understanding of what was going on. Still doing that, okay? At a career that started for me, let me say formally I guess in terms of posing questions and trying to get answers, at about age twenty-one, so that's more than fifty years ago. It's approaching sixty. So

to have this privilege of being able to design, craft a serious question and figure out how to address that question, and sometimes it involves other people. Frequently it does. And so, the bigger the question, the more people have to be involved to provide the answer, and the more information you have to think about to pose a question. But there's still that moment of discovery when you're excited because you know something and no one else knows.

GRAYSON: Nobody else knows.

FUTRELL: No one else knows. As a teacher, what has thrilled me the most, actually, is when I know perfectly well what answer should happen, and have a good student who's helping to answer that question, doing things with his or her hands, and posing that question, and they get an answer that's not the one I expected. Why not? Okay? Then that's even more exciting, when based on all your knowledge accumulated for more than fifty years, and you're wrong, because then it's something that's really significant that's come to your attention. So, what should I say? It's the thrill of the hunt in a very different sense...

GRAYSON: The intellectual hunt.

FUTRELL: The intellectual hunt. Yes.

GRAYSON: And this last century I would say I think the presence of women in scientist has increased dramatically, and I just have visited your lab and been introduced to two very brilliant and exciting women scientists who are quite knowledgeable. What is your attitude towards women in science these days, and through your career, and how it's changed?

FUTRELL: My reaction to women has been the same since I was a teenager. Wow. [laughter] Now the reasons for saying wow have changed somewhat as you get older, and I'm thrilled that there are so many women in science nowadays. I still remember the first PhD student, first woman who got a PhD with me. It was distressingly far along in my career, because when I started in my career, it was really rare to encounter women at let's say research one universities doing cutting edge research. So Julie Biggerstaff was my <T: 10 min> first woman PhD. This was actually at the University of Delaware, which was my sort of fourth station stop in doing my own research. It took a long time for women to emerge.

Earlier on in my interview, we talked about the fact that the French spelling of my name, which is ancestral in its origin, and we can go back to France, and that's a very common name, in French Canada a very common name. It's not so uncommon in Louisiana, but nevertheless, I was assigned to the women's dorm when I started college. That lasted for about five minutes before I was ejected. [laughter] But anyhow, I've been often mistaken for a woman, and I still

get pantyhose occasionally that my wife is delighted to have. These come on advertising things come in the mail, maybe misdirected. And we get a lot of phone calls, particularly asking for political donations lately, where my wife answers the phone and they think that she is Jean, and so on, and launch into that. So anyhow, I certainly experienced in subtle ways, I would say, no obvious ways, no confrontational ways, but I experienced in subtle ways in my career, as I was starting out, before I became a known quantity in the scientific community, I experienced subtle discriminations. Again, we described in my interview, when I got a letter from a vendor that I thought had done a terrible thing in the chemical that they had supplied for my laboratory, that had nasty consequences well beyond what they might have anticipated, and the letter started out, "My Dear Miss Futrell, what you have described could not happen." That was the most overt example that I personally experienced.

And I responded in a very specific way. I called them on the phone, and in my gruffest voice explained that I was Dr. Futrell, please, and that there was no doubt what I said in my letter was absolutely correct. And it was, of course, absolutely correct. I wouldn't have made those accusations without knowing they were true.

I had another experience as a woman, actually when I started my academic career at the University of Utah. Again, because of my name, I was misinterpreted by a prestigious book titled as more or less, *Who's Who Among American Women*, or *American Women in Science*, or some such title.²⁹ And so this was a very scholarly work, a book that had full interviews with people who were doing outstanding things scientifically. And I looked at the book, and I liked a good bit of it. But they had an appendix where they put in names of people that were noteworthy for recognition, names of women that they did not have time to interview, and I had been identified as the youngest woman full professor in a research one university science department in the United States.

GRAYSON: Oh, wow.

FUTRELL: So, for two to three years I was getting phone calls from sociology departments or psychology departments. I could have been the subject of several theses, but for the technicality that I was not an outstanding young woman full professor. [laughter] And so it was clearly there, okay? And it's still there, but it's disappearing.

To leap forward to my academic responsibilities when I was at the University of Delaware as a department chair, we had the distinction for a few years of having more women on our faculty than any other research one university department of chemistry. And I was fortunate to have several full professors as women. And I was trying to hire more <T: 15 min> smart women, but mainly as assistant professors just entering] the teaching profession. And I found it was easy to convince my male colleagues that so and so was very good and was worthy

²⁹ *Who's Who of American Women*, 7th ed. (Chicago, Marquis Who's Who Inc., 1972-73).

of serious consideration for appointing as a woman assistant professor. The full professors, who'd had such a difficult time battling their way to the top, they were much stricter in their criteria for hiring a woman than I was.

GRAYSON: This is your women professors?

FUTRELL: My women [full] professors. My women professors were the ones that it was difficult to convince that some young potential colleague was deserving of a chance to work with them on the faculty.

GRAYSON: So in your position, training research scientists, you had the opportunity to mentor a variety of people, and you've also been mentored in your career. What kinds of comments can you make about the mentoring that you got in progressing in the scientific career?

FUTRELL: Well, that's a fascinating question to think about. Mentoring and I might just mention, we again discussed in my interview that my present title at the Pacific Northwest National Laboratory is a Battelle Fellow. Battelle Fellow is a corporate designation, and one of the characteristics is you can describe what you want to do, and then PNNL will look at it, and if they agree, then you have a plan for what you'll be doing for the next year or sometimes two years. And so oddly enough, one of my assignments—I'm actually paid part of my salary for doing it—is to mentor younger scientists. The two young women that you meant—that you met today that you commented that they were really impressive scientists, knew what they were doing, interesting science, and so on, are two of the people that I mentor. And it's fun to talk to them, as you can imagine. And I think it's amazing that I'm paid part of my salary for doing something like that.

Now mentoring, what mentoring did I get? I got guidance. I don't think I got mentoring very much. And actually, philosophy when I was in school and the early years of my career was more to bust people out, you know, to knock them out of the system, rather than inviting them in, and talking about some of the great possibilities. It was a different era, because it was the Cold War, and we were very concerned about what was happening in the Soviet Union [Union of Soviet Socialist Republics]. Sputnik flew into the air, was orbiting the earth, while I was a graduate student. And so, getting the best people in science was a very strong national priority, and because of this, a lot of people were trying that were not judged to be, by the faculty in charge, to be capable of doing that. And so the whole attitude is there's lots of raw material to go into science, and so you can be pretty harsh in how people are treated.

The way that I sort of felt I was mentored, to use your word, as a graduate student, was so different from what they wrote in the letters of recommendation after I had succeeded in going through the experience of...well, it was my privilege to be at what was the number one

university in the United States for what I was interested in doing at that point in time, and so it was remarkable to have that opportunity. But it was not the happiest time of my life by any means. I think had I not had a couple of those moments where all of a sudden I had an answer, and in particular, when I proved the more senior people wrong and could talk about that in a research seminar, that was fun. That was fun. Still is. Still is, after all these years.

Mentoring...very, very important. When I had a position of administrative responsibility as a department head <T: 20 min> [at Delaware] mentoring was a big part of what I was doing with younger faculty. [I assigned to each new assistant professor a mentor], a “big brother,” someone who agreed to work with them, to help them to get started. And I actually did quite a bit of that myself. And so I saw to it that my...actually, out of departmental discretionary funds, I funded travel for my junior faculty, assistant professors without tenure, helped to guide them on how to get an invitation to give a seminar at a major university that had one or more faculty members, senior faculty members, working in their field. Get them the experience of going out and talking about their science and so on. And I personally took them to Washington D.C. to meet the program officers in the primarily National Science Foundation for university scientists, but also other funding agencies.

They became known persons, and they knew the people at the other end, and generally program officers are surprised when someone comes in, takes the time to visit with them, and so on. So, mentoring is a really important part of the training of a young scientist. And I think what I did is no longer exceptional. I think it’s the way it’s done nowadays.

GRAYSON: Science is actually, probably surprisingly to a lot of people, a fairly competitive business. And I’m just wondering what you think about the kinds of competition that you’ve experienced in your scientific career.

FUTRELL: Well, now. [laughter] It was a surprise to me. Let me back up a second and say that my approach to science, I finally figured out what I did, after I’d been doing it for a goodly number of years. But it was to think of a problem for quite some time, and how is it that you can approach solving this problem. And in my case, it very frequently involved some kind of innovation, to take an existing spectroscopic tool or something like that, operate it in a different way, to run an experiment backwards, and think about it backwards, and if you run it backwards, what are the implications for running it forwards? And then maybe developing a special approach that would give you a definitive answer when your competition, people who are writing the literature, sometimes much better known than you are, are interpreting things in a certain way. And when I could give a definitive answer, I thought they’d want to know that.

Well, guess what? I think you probably know this, but scientists are just people, okay? They have our strengths and our weaknesses, and sorry to say, sometimes the drive to succeed causes people to be selective in their data. I don’t think I’ve ever done that. I’ve been my most severe critic, I think, in terms of doing experiments. I like to think that. But, you know, there are historical things that I looked into. [Robert] Millikan Oil Drop experiment was one that I was

interested in, just reading about it and looking into it. And I got access to copies of his original notebooks, and he put circles around the right answer, okay?³⁰ And he ignored a lot of numbers that were giving the wrong answer. Now he didn't explain why he did that. I'm quite sure that he had a reason, okay? But he didn't put it in the notebooks. If you just looked at it objectively, you would say that he's selecting numbers as if he knew the right answer, but nobody knew the right answer. Okay? And so you couldn't accuse him of cheating, because he was the first one to get the right answer and get it to three significant figures. <T: 25 min>

Anyhow, the graduate student who worked with him in doing the critical experiments actually had gotten his undergraduate degree at the University of Utah, and so we invited him back, and I was his host, and he didn't know why his boss circled these answers. They apparently didn't discuss it, as much as I tried to do with my students when we were doing things together.

And so anyhow, there are certain biases that creep in. There are some that are not—not bad biases, okay? A saying of Henry Eyring, one of my dear colleagues at the University of Utah, very famous scientist, is that he described his theory that he was famous for as not being completely correct. It had flaws in it. He knew that. He talked to me about some of the flaws, and he tried to discover them first. Occasionally somebody else discovered one or another of the errors. But he says, “It's awfully close to right. And having done it enough times, having been a practicing physical chemist for a number of years, I can guess the answer with pretty good intuitive accuracy.” And if the answer you guess is not the one that's verified by your calculations, or in my case, by your experiment, think it over again. There's probably something wrong with your experiment. If there isn't, if there is not, then you've really discovered something interesting.

So how is it received? Sometimes joyfully, sometimes with enthusiasm, sometimes with a little jealousy because they didn't have the proper tool to do the experiment and get the answer, and so on. So, scientists are people. You encounter all spectrums of emotion and talent and whatever. And there are even some people that I knew that were graduate students for a while, had incredible intuition. If I could somehow have gotten them to do the math and to survive an oral exam at the end, I think they would have been great scientists, and recognized. But you can't do it just because you're good at something, because you have a skill.

And science is creative, okay? I don't think the public image of a scientist is of a creative person, but it's really true. And, you know, way back in ancient history, means before I was born... [laughter] Back in Vienna [Austria] there were actually orchestras that consisted of scientists, orchestras that were all mathematicians, and so on, and so on. Interest in art and music, those kinds of things, is not completely foreign to a scientist. As we mentioned already, my wife is a noted artist who has work in the [Cooper-Hewitt—the Smithsonian Design Museum], and clearly she's a creative person. No one would doubt that. Anyone that visits my office, actually, sees some of her work that's hanging on the walls, or our home, would agree

³⁰ Robert A. Millikan Oil Drop Experiment Notebooks, Notebook Two, <http://caltechln.library.caltech.edu/8/>

that she's creative. They wouldn't immediately guess that I'm creative. But I claim that I am, and my artist wife agrees. [laughter] I guess that means some of the things that I talk to her about are so crazy from her perspective, that she agrees that they are creative.

GRAYSON: Fantasy is creative.

FUTRELL: Fantasies. Yes. Somewhere between creative and fantasies.

GRAYSON: So you have spent a number of years, some number of decades, in the science specific field. How do you think it has changed from the beginning of your career until the present time, the whole business of practicing science and pursuing science? Is it—how is it different now than it was at the <T: 30 min> beginning?

FUTRELL: Well, I guess the speed of doing things more than anything else. Of course, in our interview, we talked about my career in mass spectrometry and how I got into it, and I described how painful it was to obtain a mass spectrum, essentially so precious a device no graduate student could come near it. And at that time, I think the only chemistry departments that actually had commercial mass spectrometers might have been the University of California at Berkeley, and that was not in the department, actually. It was in the [Lawrence Berkeley] National Laboratory, and students could have access to that.

The departments of chemistry that did mass spectrometry typically were places where the pioneers were. They built their own. And so, at the time I was entering the field, there were very few and very simple mass spectrometers. We discussed the fact that mass spectrometry really got launched in significant numbers by the oil companies during World War II. They were invented to control what they needed to do in refineries. And so that's where they were, and therefore early leaders in the field, practitioners, probably many more, many, many more, came from oil companies than from universities, for example. So it was a very delicate and time-consuming business.

We saw today one of my colleagues who worked with me for a dozen years, maybe a little bit more, in the laboratory, and I'm quite sure that he obtains more mass spectra in an afternoon than my students and I did my entire career, no doubt. No doubt that he does that. And so, extremely high throughput is a characteristic now of doing certain types of mass spectrometry. Instead of a week to get an answer, the instrument gets in a fraction of a second, and the computer tells you what you've done. Huge change in the speed of which data is obtained [and sometimes it leads to data overload]. And actually, I'm thinking of a conversation I had with a distinguished chemist, Linus Pauling, two Nobel Prizes to his credit [1954 in Chemistry and 1962 in Peace], and he is somewhat older, and not able to have this interview with you, but I remember a conversation where he objected to all of this detail.

The conversation is I was showing him a gas chromatogram that one of my students had obtained, and with a mass spectrometer, we could put names on all the peaks, and this was a capillary column gas chromatograph. And so, there were literally hundreds of peaks, and Linus Pauling looked at it and he said, "I don't like this at all. I can't see a pattern. I can't get the science that's behind this piece of paper that you're showing to me." A really visionary scientist was not prepared to deal with data.

A frustration of mine is that you have this wealth of data, and most of the practice of science has several computers in between you and the actual experiment. That's a personal frustration, and it's a characteristic of the 21st century, absolutely missing in the 20th century. So anyhow, I think it's harder to have these breakthrough thoughts where you see what nature is trying to tell you that you haven't thought of yet. I say that despite the fact that I published theoretical papers on pattern recognition and used computers, and I too have sinned, but I'm not comfortable with it.³¹ [laughter] I have to say that. I'm not comfortable with it.

GRAYSON: So lastly, I'd like to get your opinion about a <T: 35 min> general theme of science and the public, the impact of say science and the common man or perhaps the impact of your scientific work on the common man. But I think this is becoming more and more crucial with the, unfortunately, what I see as the politicization of science today. So, talk to me about the science, how you think science is seen by the public, and how the common man sees it, and how maybe the work that you've done has impacted the common man.

FUTRELL: Well, my impact on the common man has been fairly indirect in a sense of a number of breakthroughs that lead to new instrumentation, and the new instrumentation eventually becomes commercialized, or not. But a number of things that were discoveries at different points in my career appear in commercial instruments, several of which you saw today in your tour of this laboratory, doing fantastic experiments at a fantastic rate. And then eventually the results of this information are communicated.

But I think our communication to the general public is seriously flawed. It's lacking in both...what should I say? The essential message gets lost in terms of how it's finally interpreted to the public in many cases. We have in this laboratory a whole department responsible for communication. Before you escape, I'll give you a number of brochures, and I'll even point to some and say, well, that's not really true. It sounds good, but it isn't. And so the communications step has...in this age of specialization...kind of stands between the practitioners of science, the real scientists, and the public to whom it's communicated.

³¹ H. L. C Meuzelaar., G. R. Hill, J. H. Futrell, A. M. Harper, D. J. Iwamoto, D. L. Pope, G. S. Metcalf, and J. H. Tomlinson. *Characterization of Rocky Mountain coals and coal liquids by computerized analytical techniques*. Progress report. No. DOE/PC/30242-T1. Utah Univ., Salt Lake City (USA). Biomaterials Profiling Center, 1981.

We do better as a scientific community with the federal agencies that are charged with the responsibilities of funding science. Why? Because it requires money, and again, the big change from when mass spectrometry was a cottage industry, but people built their own, to, you know, thousands of them are sold throughout the world every year. Total change in the way things are done. And specialization. People in this laboratory are represented to the outside world by a number of different people. To the funding agencies, they are represented by administrators who are charged with communicating the value of what we're doing, and so on. And then people in communications who produce glossy brochures and videos and things like that, and digital communications, social media. We have a public website that we invite people to look at, and then we have the internal website, because there's security issues that separate us from the public outside, is sometimes penetrated. I just noticed that I was a wealthy person, because I got the email telling me I've got an unimaginable sum of money. Well, this is not true, and probably more than fifty percent of the information that comes through [to me on a typical day at the office], having been filtered by one hundred or so people that are supposed to catch messages that are inappropriate, because they mention something that sounds like it might be real, comes in [unfiltered].

I spend a discouraging part of my time rejecting communications that are aimed at me. [I think most people have similar experiences, complicating our attempts to communicate real scientific information]. Well, our communications are inspired by trying to communicate the value of science, communicate it to the scientific public, communicate it to our sponsors, the federal government, and because the source of all this is taxpayers, to the public at large. And so, we have a very large investment in communication, but I don't think it works very well. [Room for significant improvement].

There's some things that get <T: 40 min> lost in the interpretation. It goes from one to another to another. And the general public is bombarded with so much information... as you and I know, having grown up before cell phones existed, and before people had laptop computers, and before I had my iPhone, and my iPad, and all the essential things you carry on the airplane these days. Bombarded by just a tremendous amount of information. And a significant fraction is pseudoscience. It's not real. And so there are a number—for a number of sources of information that pretend to be scientific that really are not. The people who are introduced as scientists are not. Universities... how many universities do we have nowadays that have no campus, no contact between a professor and a student, but people are paying money to get a degree that says you have a university degree. That's not the university education that you and I had, and it doesn't mean the same thing at all.

Science is a contact sport. We talked about that. You have to communicate with people, and it's very much a human endeavor. I like to think it's part of what distinguished humans from our ancestors, and when it became more important to be in an air conditioned office, an air conditioned laboratory, thinking profound thoughts, than to take your club out and kill a tiger. So, we've advanced as a civilization.

I think science and technology [are twins]—technology is equally important. That's the application of scientific knowledge to enable us to do things better, faster, cheaper. We've

experienced this speed-up over and over and over again. You know, there are things that people think of, public understanding of things that are called laws and theories, are not laws and not theories. First of all, a scientific law has nothing to do with the practice of the law, and you find that out as soon as you get in a lawsuit, for whatever reason, innocent though you are. So, you understand law has a different way of practice than science does. I don't think it's as creative. That's my personal opinion. But anyhow, one of the laws that has governed our lives for a few decades now is Moore's Law. So Moore's Law says the speed of computing has a doubling time, and this was obeyed for more than two decades. I think perhaps more than three decades. But it's not true anymore, okay? Because it never was a law. It was not prescribed by physics and physics principles. It was an observation that humans, scientists, engineers, technologists, were clever enough to figure out ways of doing things faster and faster and faster and faster. And the devices to do it got smaller and smaller and smaller.

But we've hit the physical limit, okay? You can no longer maintain an information bit and make it faster and faster and faster. That's why the room that we have computers in has expanded another fifty percent, because we've got to put more of them to double our speed or triple our speed of communication, of use of computers. And of course, probably a third of our computer space is now information. What do you do with information? So, there's a whole new specialty in finding out what the patterns are that nature knows about and we do not. The image of a scientist, my image of a scientist, has changed dramatically over time. I think to the general public it's a even more foggy notion.

GRAYSON: Well, very good. I think that kind of wraps it up, unless you have any final comments—parting wisdom—that you want to give to the ages. [laughter]

FUTRELL: Well, I don't think I have any real wisdom to impart to the ages. You know, there are a few <T: 45 min> principles we've talked about, particularly in my interview. I think not being afraid to admit you don't know the answer is an important philosophy that people should keep in mind in all walks of life. One of the things that has occurred in the information age is now you can find either an answer out there. Frequently you find several answers, not all of which can be correct. But by doing a little research, starting with the internet, and maybe going to an old-fashioned thing like a library, you can identify a person who knows a lot more about a question than you do, and it doesn't hurt to ask. And you can generally get them pretty quickly nowadays.

It's the golden age of science. An ancient quotation is, "This is the best of times, this is the worst of times." Best of times of being able to do things, worst of times in terms of sorting out what it is that you can do and should do in contrast to the things that might be done. I think that's the best I can do for closing remarks.

GRAYSON: I think that's probably pretty darned good. [laughter]

FUTRELL: Thank you, Mike. This has been fun.

GRAYSON: Yes. Well, I've enjoyed it [also].

[END OF AUDIO, FILE 2.1]

[END OF INTERVIEW]

APPENDIX MY STORY*

August 2014

As a radiation chemistry graduate student at the Lawrence Berkeley Laboratory in 1955-58 I had my first encounter with mass spectrometry as an analytical instrument. Figure 1 shows the author as a first year graduate student practicing state-of-the art bulb-to-bulb separation of volatile gas samples into several—typically five—fractions for analysis using the newly-acquired CEC 21-103 mass spectrometer at LBL. These fractions were submitted to the MS technician who returned to me the next day scrolls of photographic paper recording mirror deflections of an optical signal at 5 different sensitivities of electrometer signals obtained as the accelerating voltage of the spectrometer was scanned—the precious mass spectra of my unknown products. He also provided me a scroll of background peaks obtained with the same spectrometer that included mercury isotope peaks—originating from the mercury diffusion pump on the analyzer tube—as an absolute mass calibration. This approach worked remarkably well for fixed gases—hydrogen and methane—and for volatile gases whose spectra were well known but failed for complex mixtures of less volatile non-hydrocarbon compounds.

What was clearly needed was an improved separation procedure and the technique that I adopted was gas chromatography (GC) which seemed to offer the solution to my problem. The core analytical method that I adopted was a combination of gas chromatography (GC) and mass spectrometry (MS)—not GC/MS, which was developed much later. Gas chromatography had been developed in Great Britain as an analytical chemistry method but had not matured as a commercial product. With fabrication of the requisite packed column filled with thinly coated, uniform size particles as my goal, my GC project started at UC Berkeley's College of Mineral Resources whose faculty provided key advice on how to proceed and loaned me a hammer, firebricks, grinder and sieves. After a year or so struggle my primitive version worked sufficiently well that collected fractions could be analyzed by mass spectrometry. Many more samples could now be submitted for analysis by the LBL CEC 21-103 mass spectrometer. This provided me with many more meters of photographic traces of my unknowns. After weeks of work measuring peak heights, searching for standard spectra, and iterative calculations with a special 1 meter slide rule that gave me an additional significant figure, I had yield data and names of compounds I could record in my laboratory notebook. This matched reasonably well the 2-3 months cycle of securing a half day of cyclotron time for the next radiation experiment. The tediously acquired data were precise and reproducible, provided the foundation for my doctoral thesis and served as my introduction to the “modern era” of mass spectrometry.

Using my best techniques of GC and MS I concluded that two of my compounds had not previously been reported in the literature and I had in my hands the mass spectra of unique compounds that should be reported to the world. I persuaded a classmate to synthesize model

* Prepared and written by Dr. Futrell, and published as part of the Foreword to *International Journal of Mass Spectrometry, Special Issue: Mass Spectrometry, 1960 to Now*, volume 377, February 2015. Text and images reprinted here with the permission of Elsevier.

compounds with methyl groups replacing chlorines in my radiolysis products and another classmate to record (and interpret) infrared spectra of my two unknowns and the structurally related model compounds. This worked out beautifully and in my euphoria I submitted as a Communication to the *Journal of the American Chemical Society (JACS)* what was intended to be my first professional publication—one of the first reports fulfilling J. J. Thomson's prediction that mass spectrometry provided definitive information on the structure of molecules. To my great surprise the paper was summarily rejected, based on the advice of two distinguished anonymous reviewers who asserted the well-known fact that "high energy electrons used to ionize molecules caused the atoms to rearrange randomly, destroying any evidence of structure." They were wrong and J. J. Thomson's prediction was right, but I lost my coveted moment of fame. The positive part of the story is that I became a serious "camp follower" observing with great interest what was going on in mass spectrometry in the 1950's.

In fact, a lot was going on, and chemists were at the forefront of this activity. I was particularly interested in ion-molecule reactions; Victor Tal'rose in the Soviet Union had just demonstrated that the rates of these reactions were orders of magnitude faster than chemical reactions of neutral species. The reason for this characteristic feature of ion reactivity is illustrated in the accompanying Figure 2 cartoon for an ion colliding with a polarizable molecule at various impact parameters—the distance between the centers of mass of the colliding pair as they approach each other.

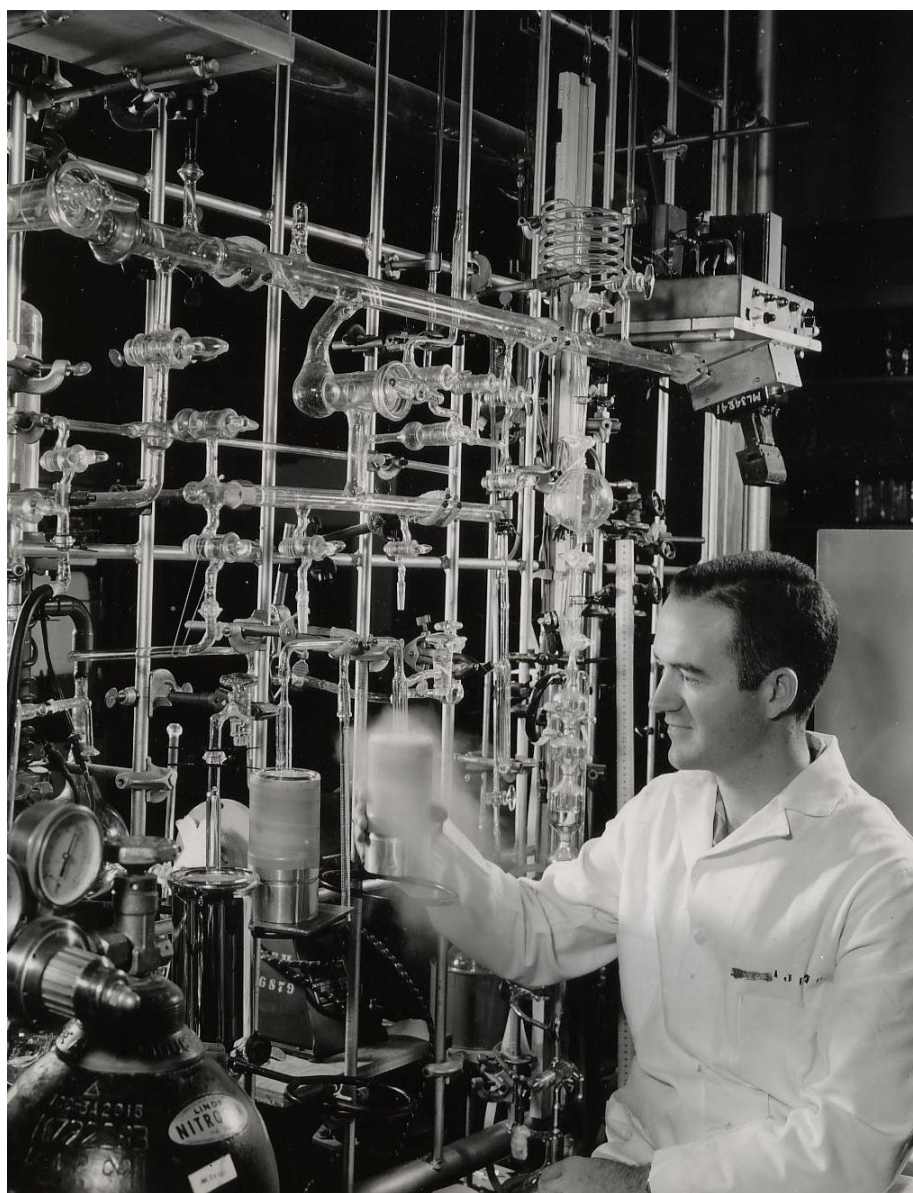

Figure 1. Radiation chemistry graduate student Jean Futrell practicing bulb-to-bulb distillation separation of radiolysis products for mass analysis at the Lawrence Berkeley Laboratory in 1956.

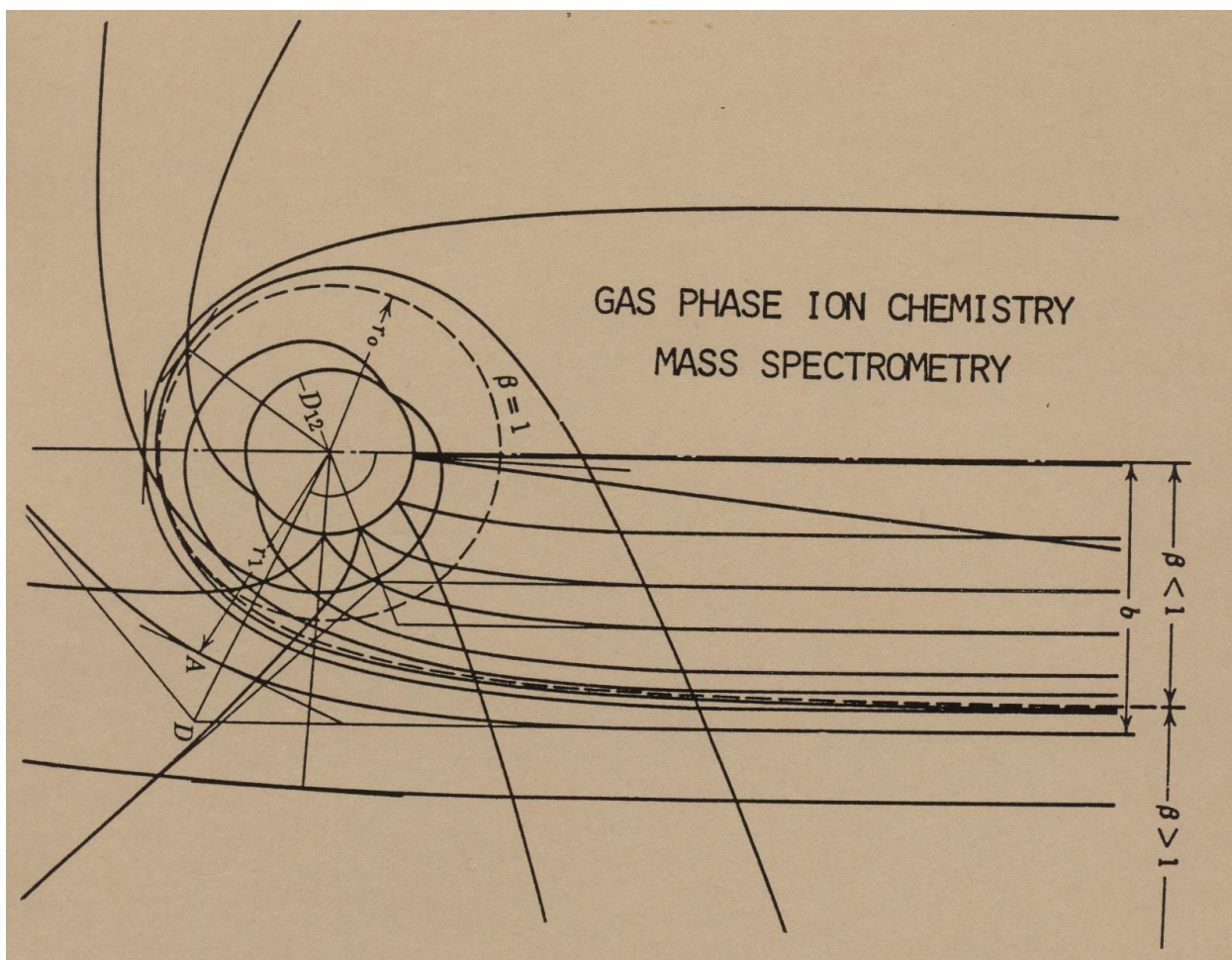

Figure 2. Schematic illustration of the Langevin Model for long range ion-induced dipole force governing the dynamics of ion-neutral collisions at low velocity

The ion-induced dipole force establishes a critical radius, defined as $\beta = 1$ in the figure, for orbiting collisions that separate trajectories into two categories of glancing deflections ($\beta > 1$) and hard-core collisions ($\beta < 1$). At the concentric sphere D_{12} normal chemical bonding forces and typical reactions of atom exchange and rearrangement govern the outcome. The critical point is that long-range forces result in collision cross-sections that are much larger for ion-neutral collisions than their neutral counterparts. For higher charge states and for stronger long-range forces—ion/dipole, ion/quadrupole, etc.—the physical interaction is even stronger, resulting in rates of reaction that are orders of magnitude faster than the most efficient neutral chemical reactions, such as free radical reactions. Ions are extremely reactive species, attacking molecules in the gas phase, in liquids, and on surfaces, as amply demonstrated once techniques for investigating these reactions became available.

This property of ion-molecule collision dynamics was the basis of an original research proposal that I was required to present and defend along with my thesis research in the final oral exam for my PhD in physical chemistry. I proposed that the fragmentation of ions in mass spectrometer ion sources were ion-molecule reactions run backwards and that the strong force of attraction between the product ion and neutral would overpower any activation barrier. It follows that the measurement of appearance energies of ions with high accuracy is well-suited for the measurement of bond energies and establishing heats of formation of radicals and ions. My committee thought it was a fine idea and history seems to have vindicated the general concept without—to my knowledge—specifically articulating that fragmentation of molecular ions is an ion-molecule reaction run backwards.

The other “hot topic” in mass spectrometry that intrigued me was the development of the Quasi-Equilibrium Theory of mass spectra by Eyring, Warrhaftig, Wallenstein and Rosenstock at the University of Utah in 1952. Now known to be fully equivalent to the RRKM statistical theory of unimolecular decomposition, this theory quantitatively linked the excitation of molecular ions with details of their fragmentation. In addition to vindicating my empirical linkage of mass spectra with structure, the QET/RRKM theory describes the time dependence of fragmentation of excited ions. That principle, along with rates of ion-molecule reactions, provided the basis for understanding the role of ion-molecule reactions in the radiation chemistry of gases—the topic of my first independent research after graduation. This occurred mainly at Wright-Patterson Air Force Base in Dayton, Ohio, where I served a two-year tour of active duty that had been deferred until I completed my graduate studies. While awaiting my USAF assignment I benefitted greatly from a brief industrial research appointment at the Baytown, Texas, Research Center of Humble Oil and Refining Company, where I learned a great deal about mass spectrometry and reaction kinetics of hydrocarbons from research pioneers Joe Franklin, Frank Field and Fred Lampe. These conversations markedly sharpened my understanding of ion reactions and reaction kinetics in general, leading to my first single-author publication that was submitted as a Humble scientist (with considerable pride rather than humility). This paper received accolades from the reviewers rather than rejection, reflecting a more advanced understanding of ion chemistry by scholars in 1959.

I had the great good fortune to be assigned to the Aerospace Research Laboratory (ARL) at Wright-Patterson shortly after it had opened its doors as a fundamental research laboratory operated by the Air Force Office of Aerospace Research. After a brief apprenticeship in photochemistry I initiated my own research program in gas phase radiation chemistry using ARL's MeV linear electron accelerator. Running the QET/RRKM theory backwards in time by four orders of magnitude enabled me to predict the ion composition at the point in time where ion-molecule reactions would take place at atmospheric pressure. My new friends at Baytown had established that proton-transfer and hydride-transfer reactions were the principal ion-molecule reaction pathways for hydrocarbons. Neutralization of product ions from this first cycle of ion-molecule reactions leads to the formation of smaller neutral molecules and free radicals; this sequence of events satisfactorily rationalized the radiation chemistry of simple gaseous hydrocarbons. My success in predicting radiation chemistry yields with an accuracy of the order of ten percent accompanied by a compelling story about the time sequence of events achieved some notoriety in the radiation chemistry community. In turn this persuaded ARL

management that further investment in ion chemistry was a logical path forward. This was very tangibly reflected in their decision to purchase a mass spectrometer for the Chemistry Division of ARL.

My first hands-on experience with mass spectrometry involved this state-of-the-art CEC 21-103C mass spectrometer shown in Figure 3. Remembering my angst at acquiring mass spectra as a graduate student, the first modification of this instrument was a UV recording oscillograph to replace the photographic recording system of the standard instrument. With this instantaneous readout we soon learned that it was a more robust instrument than the instruction manual implied, that one could adjust most parameters somewhat beyond the range suggested by the manual and that the rigorous prescription on timing sample introduction and cleanup could be violated at tolerable cost to performance.

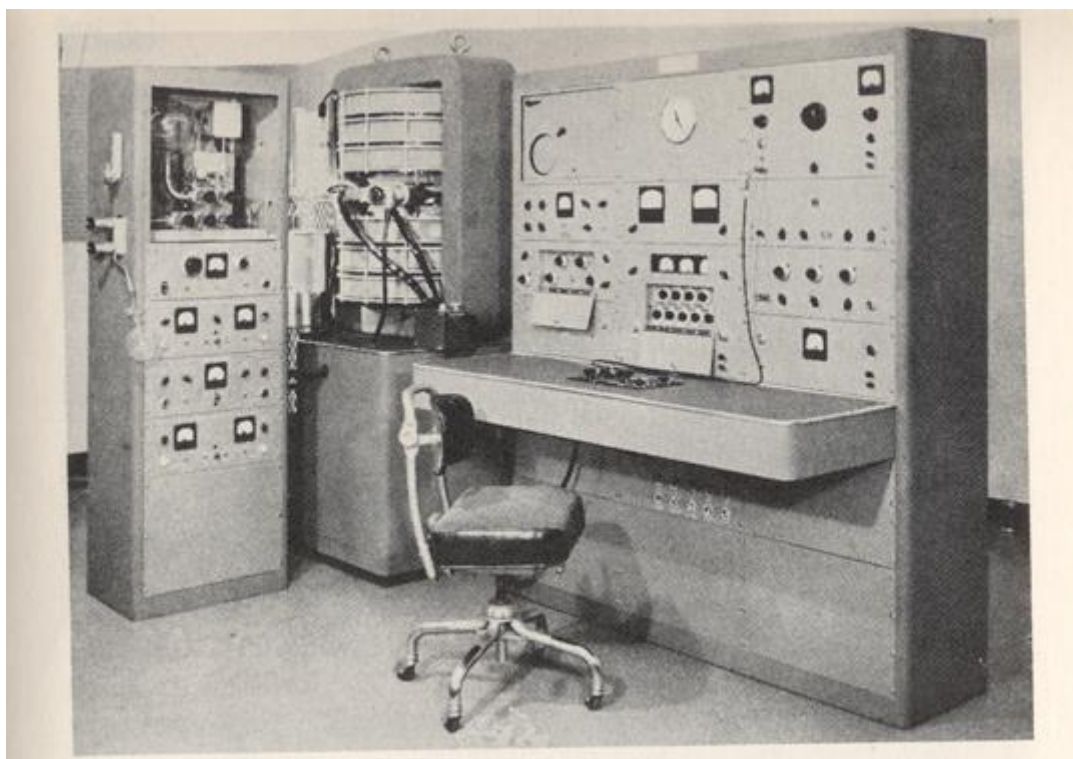

Figure 3. A photograph of the Consolidated Electrodynamics Corporation Model 21-103C mass spectrometer.

With an instrument totally under our control and with my first set of coworkers to help we began to do unconventional things with this remarkably sturdy instrument. We modified sources, pumps, power supplies and inlets and began to do the kinds of real chemistry studies I had witnessed in Baytown. We found ourselves limited by sensitivity—a very common complaint—and noted electron multipliers were being used on more advanced instruments that

incorporated detectors outside the magnetic field. The 21-103 detector was immersed in the uniform magnetic field, precluding use of such a detector. However, when there is a will there is (often) a way. Inspired by the Wien filter (developed by Wilhelm Wien in 1898 for investigating positive ions generated in electric discharges), which utilized crossed electric and magnetic fields to select and characterize a single ion species, we brought the ion beam outside the magnetic field by creating an ion transfer device whose electric field gradient matched the magnetic field gradient of the spectrometer. A hand-held Gauss meter that was now an item of commerce was used to map the magnetic field; this provided the needed information on magnetic field gradient and the Wien filter concept gave us the electric field gradient required to keep an ion in focus as it was extracted from the uniform magnetic field region. This gradient was implemented using a series of plates connected to a voltage divider that was scanned along with the accelerating voltage to extract focused ions to the low field region required for electron multipliers to function. This device provided us with five orders of magnitude increase in sensitivity and opened up a wide variety of experiments in ion-molecule reaction kinetics. In turn, these successes inspired ARL to invest in Time-of-flight and very early, non-commercial versions of quadrupole mass analyzers. Continuing success led to my becoming a civilian scientist after the conclusion of my tour of duty and shortly thereafter to the ARL Chemistry Division's largest instrumentation investment—an in-line tandem arrangement of two double-focusing mass spectrometers.

The accompanying figures are a schematic view of the first and only five sector tandem mass spectrometer incorporating two double-focusing mass analyzers as the ion gun and product analyzer elements. Figure 4 shows a schematic view of the device, while Figure 5 shows my first doctoral student, Captain Larry Bone, pretending to do an experiment with the device.

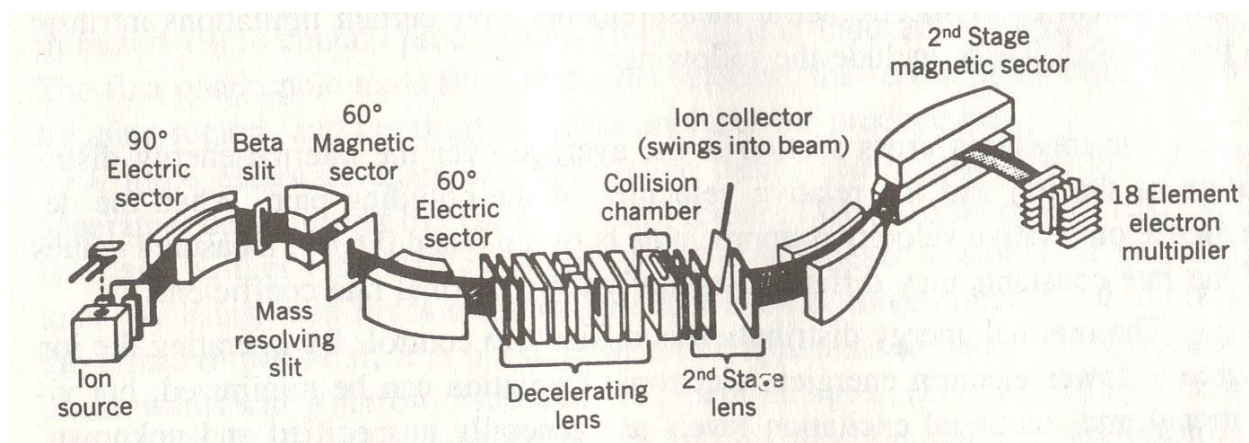

Figure 4. Schematic view of ARL five sector tandem mass spectrometer. The ion gun is an electron-impact ion source for a miniature Nier-Johnson geometry mass analyzer and an electric sector that aligns the beam with a novel decelerating lens that injects the mass- and energy-selected ion beam into a collision cell. Product ions are extracted and accelerated into a Mattauch-Herzog geometry product ion analyzer identical in scale to that of the CEC 21-110 high resolution mass spectrometer.



Figure 5. Captain Larry Bone at controls of ARL tandem mass spectrometer.

This elaborate multi-sector spectrometer, fabricated from state-of-the-art “best effort” components, all worked individually as ion-optical elements but collectively failed the critical challenge of decelerating ions to the quasi-thermal range, reacting them and reaccelerating them for mass analysis in this one-of-a-kind apparatus. This failure, along with the high cost of constructing the apparatus, critically focused the author’s attention on charged particle optics. After many trial-and-error attempts consultation with experts at the National Bureau of Standards (now the National Institute of Standards and Technology) provided an effective solution to this vexing multi-dimensional problem. It also resulted in the invention of what later became the standard rectangular tube lens design that exhibits almost twice the focusing power of a slit lens; this was critical to the deceleration of ions injected into the reaction chamber. Additional vertical and horizontal lenses and steering elements were also required for the apparatus to work as intended. The end result was very successful, enabling the quantitative investigation of ion-molecule reactions of arbitrary complexity over the kinetic energy range of 0.5 eV to 200 eV. These numbers are no longer impressive, but represented a decrease by more than an order of magnitude of the lower limit for ion beam studies of ion-molecule reactions.

This achievement and the rash of publications and presentations describing the kinetic energy dependence of rates of ion-molecule reactions generated considerable interest among the growing international community of scientists interested in ion reactions.

Despite the great success of the ARL tandem, the author left ARL and this specialized instrument for investigating ion-molecule chemistry to launch his academic career at the University of Utah in 1966. The field of ion-molecule chemistry was expanding rapidly, and two new developments—Munson and Field's invention of chemical ionization and John Baldeschweiler's incredibly successful deployment at Stanford of Peter Llewelyn's invention at Varian Associates of drift cell ion cyclotron resonance—were transforming the study of ion-molecule reactions. The reductions to practice at Utah of these two developments was the focus of my initial research efforts in my new environment.

As noted previously, the theory and practice of mass spectrometry at Utah was well advanced before I joined the faculty. A new chemistry building and new instrumentation, including a CEC 21-110 double-focusing mass spectrometer, were additional attractive features. The spectrometer was the departmental service instrument but was made available to me and my students for launching my academic research program. This became our platform for exploring chemical ionization mass spectrometry, once we cleared a major hurdle to operating chemical ionization sources at high voltage.

Figure 6 highlights the changes required to the standard electron-impact ion source with a chemical ionization source operated at approximately 1 Torr pressure. This was the first example of a chemical ionization ion source deployed on a double-focusing mass spectrometer. The colored portion of the figure outlines the changes that we made to the standard instrument to enable the operation of a grounded gas inlet system connected to an ion source operated at elevated pressure. Our modifications included an enclosed ion source, a higher capacity oil diffusion pump and a novel spark suppressor. It was an unfortunate coincidence that the typical operating pressure of a CI source is also the optimum pressure for striking a gas discharge. Operating at 2 orders of magnitude higher or lower pressure eliminates this problem. The option of floating the sample introduction manifold at full accelerating voltage was rejected for an instrument that served as the departmental service instrument and we decided that dropping the voltage in a controlled fashion was a preferred option. Our novel spark suppressor is in the approximately 3 meter glass tube connecting the inlet manifold to the ion source. Inside the connecting tube a series of glass-encapsulated resistors reduced the field gradient from the ion source to the grounded sample introduction manifold by two orders of magnitude.

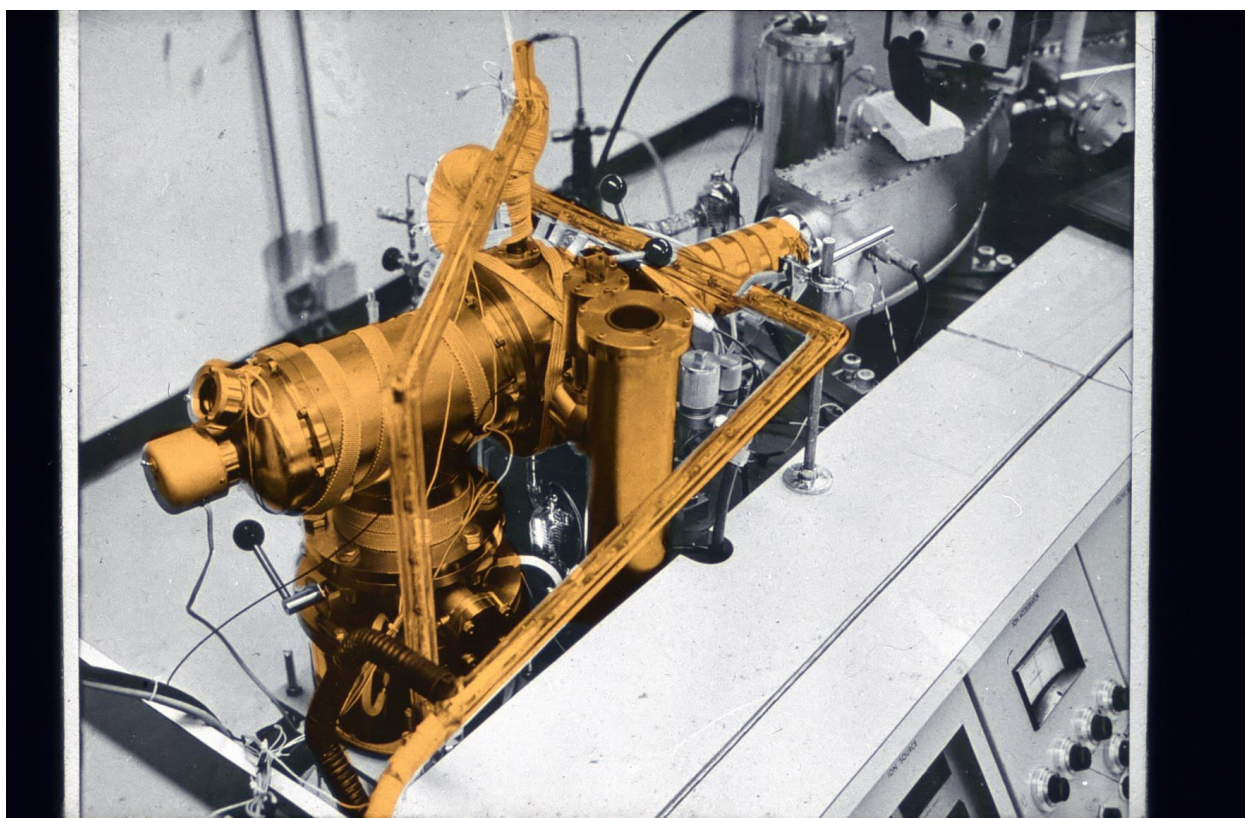

Figure 6. Chemical Ionization source and gas handling system deployed on a CEC 21-110 double focusing mass spectrometer.

This initial research effort was sponsored by CEC and our first demonstration to the sponsor taught us an important lesson. We introduced the amount of sample that they, and we, thought would give a meaningful ion signal based on the much smaller dimensions of the electron gun entrance slit and ion exit slit of this source relative to their standard electron impact version. Our CI signal was so large it required 24 hours to pump the sample to low enough value to repeat the experiment, this time with a hundred times smaller sample. This reminded us once again of the extraordinary efficiency of ion reactions in general and of proton-transfer reactions in particular. It is also one of the reasons that chemical ionization ion sources were popular tools of the trade in analytical mass spectrometry for decades.

Ion cyclotron resonance replicated and then displaced many of the experimental capabilities of the ARL tandem mass spectrometer and I wanted to be part of this “new wave” of research in ion-molecule chemistry utilizing this technique. I knew the phenomenon of ion cyclotron resonance quite well from my graduate student days at the Lawrence Berkeley Laboratory. One of the duties of graduate students was giving guided tours of accelerators to distinguished visitors. Figure 7 is a photograph of visitors touring one of the cyclotrons that I now understood was an ion cyclotron resonance spectrometer with a limited mass range—specifically, protons and deuterons. Baldeschweiler’s extraordinary success at Stanford was

based on a somewhat smaller 9-inch electromagnet that Varian had developed for NMR studies emphasized ion-molecule chemistry rather than accelerator physics. Not having LBL's budget but prejudiced by my early research efforts that "bigger is better" our Utah venture in ion cyclotron resonance (ICR) utilized a 12-inch electromagnet rather than the 9-inch Syrotron marketed by Varian.

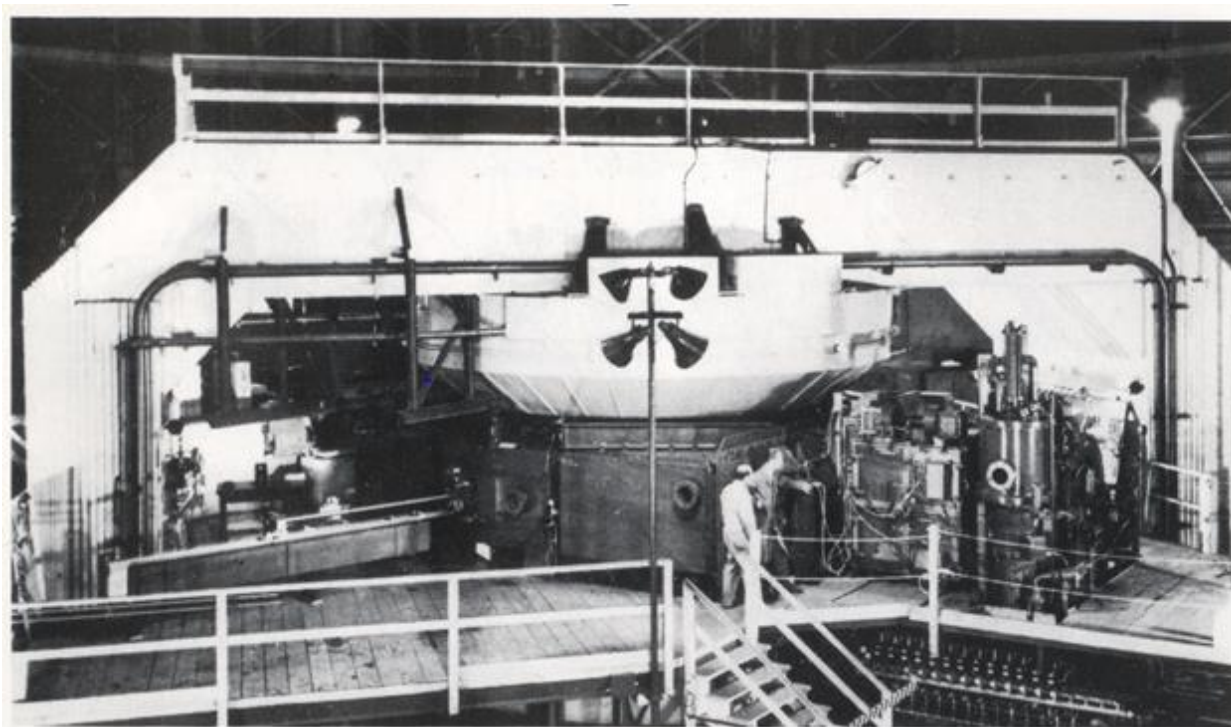

Figure 7. Synchro-cyclotron accelerator at Lawrence Berkeley Laboratory, circa 1955. The magnet weighed 4000 tons and the cyclotron resonance radius for protons injected into this magnet is 4.7 meters.

The larger magnet basically provided more space for expanding the repertoire of ICR experiments to include new cell designs, additional optics, better differential pumping, etc. We were tightly wedded to the tandem mass spectrometer concept and also intimately familiar with Dempster's velocity focusing principle used in the Fig. 3 21-103 mass spectrometer. This led to our concept for a "better" ICR shown schematically in Figure 8; the underlying principle for this particular tandem mass spectrometer is that direction focusing in a uniform magnetic field produces an exact image of the ion source at 180 degrees. It follows that ions formed at rest in a narrow electron beam would be precisely focused at a well-defined point in a uniform magnetic field. Near thermal energy was also the ideal starting point for applying the double resonance techniques developed by the Stanford group for investigating ion-molecule reaction kinetics. To ensure that only thermal energy ions got through we inserted a mass-resolving "slot" lens (width

establishes the maximum diameter of ions spiraling in the uniform magnetic field) that set an upper limit of 0.1 eV for ions injected into the ICR cell. This device, shown schematically in Figure 7, was later recognized as the first external ion source for an ion cyclotron resonance mass spectrometer. (When the author gave the Wolfgang Paul Lecture a few years ago at a meeting of the German Mass Spectrometry Society it was quite startling to see this schematic on the napkin at the dinner given in his honor.)

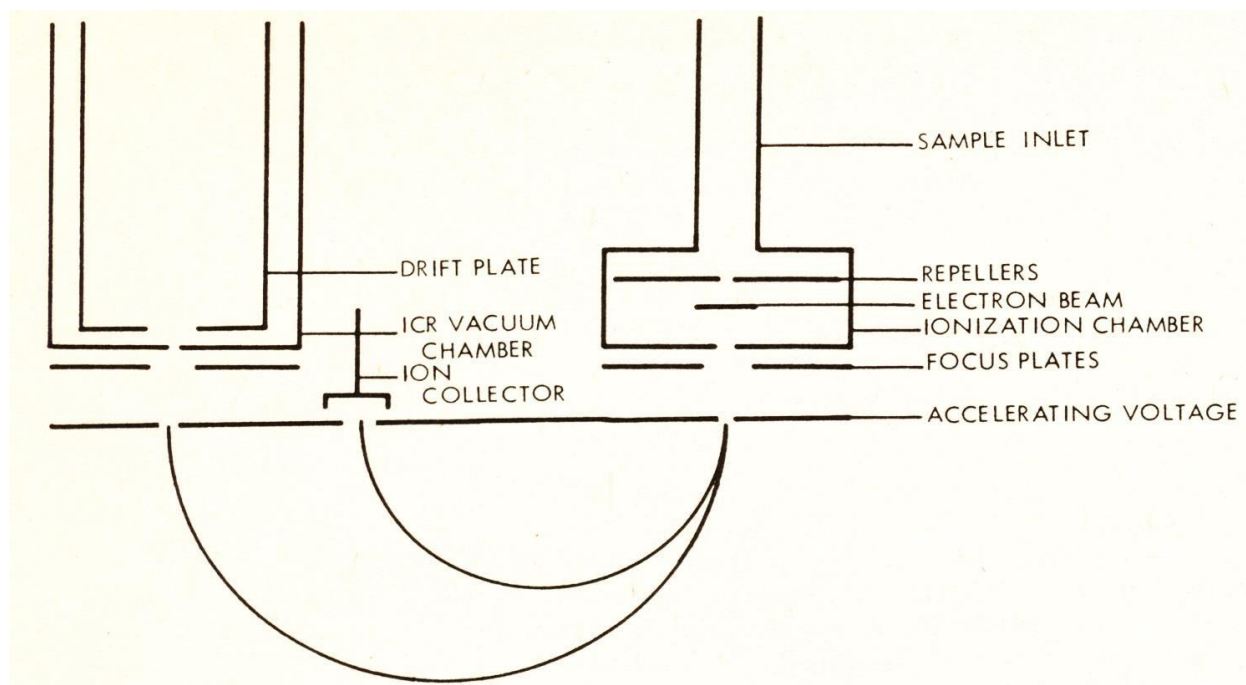

Figure 8. Schematic of Tandem ICR mass spectrometer developed at the University of Utah

My first post-doc at the University of Utah, Dr. David Smith (now retired from his academic career as Professor and Director of the Mass Spectrometry Resource at the University of Nebraska) was the principal architect of this device is featured in the Fig. 9 photograph. In its day it was a remarkably effective tool for investigating ion chemistry of truly thermal kinetic energy ions.

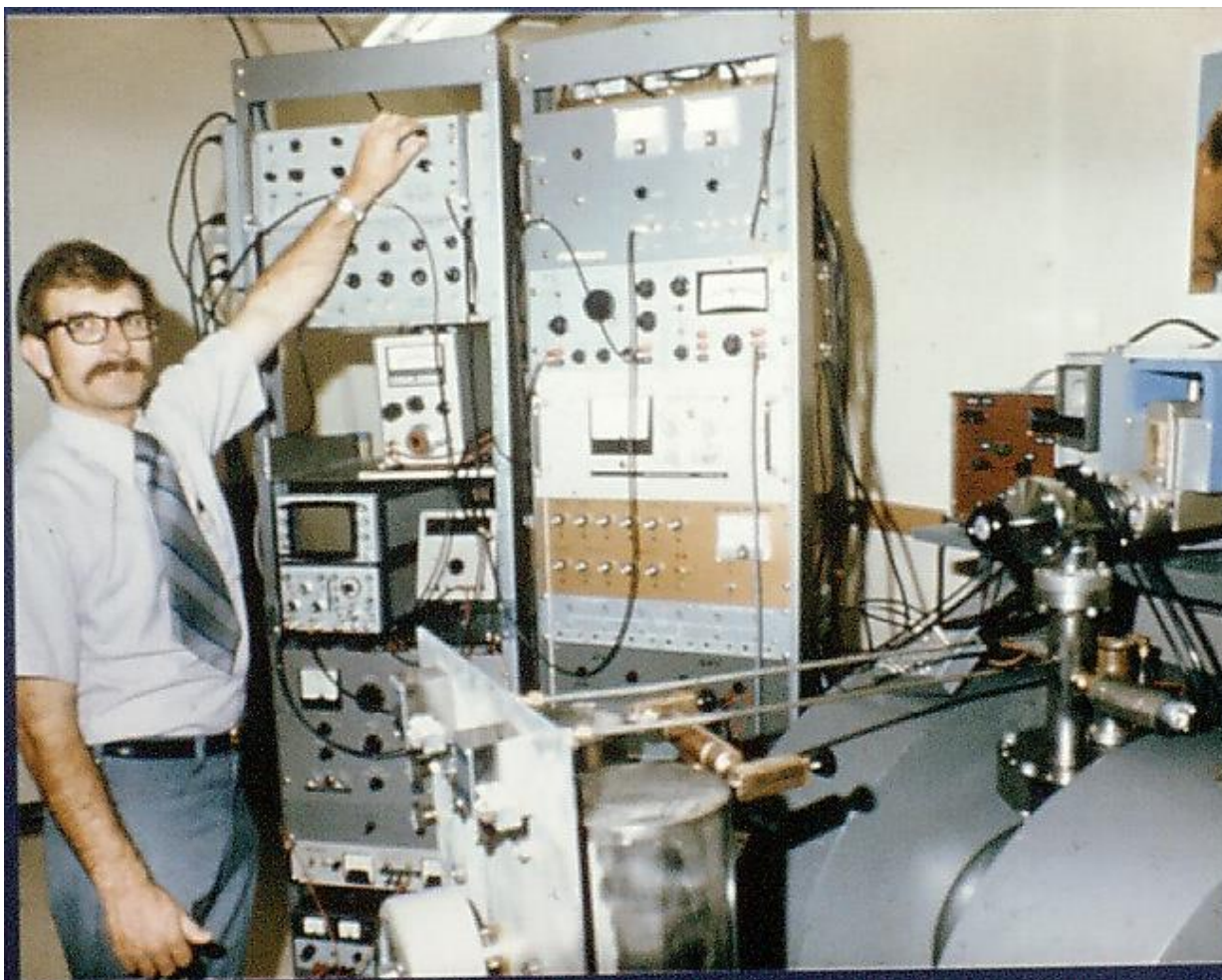

Figure 9. Dr. David Smith poses with the Utah tandem Dempster Ion Cyclotron Resonance mass spectrometer.

Utah was a very fertile ground for making instrumental advances and I was privileged to have many talented graduate student and post-doctoral co-workers who enjoyed dissecting commercial instruments or building something entirely new. I learned a lot from all of them and cite one of them, Marvin Vestal, as an example of an especially talented teacher/student. Marvin had worked with me from time to time beginning in the ARL era and decided to join me as a graduate student to formalize his graduate credentials. He received the first PhD in Chemical Physics awarded by the University of Utah. Although it was not crafted specifically for Marvin this interdisciplinary degree program for students who desired more physics content than the program in Physical Chemistry was a perfect platform for his graduate career.

Marvin was a major player both in creating novel instruments and using them to solve interesting scientific problems. Figure 10 shows him and the director of the Utah Machine shop, Bill Wilcox, sawing the ion source off a new AEI MS-30 dual beam mass spectrometer to attach an improved chemical ionization source for simultaneous EI and CI mass spectrometry. Figure 11 shows the novel crossed-beam scattering apparatus designed by Marvin as a key part of this

thesis and constructed mainly with spare parts—a vacuum bell jar, an obsolete single sector mass analyzer gifted to the Department and a home-built quadrupole mass filter. Figure 12 is a photograph of the actual apparatus. This scattering apparatus utilized a supersonic jet to accelerate the neutral reactant and a novel exponential lens to decelerate ions to near-thermal velocities. It enabled the first studies of the dynamics of ion-molecule reactive collisions in which the velocity of the neutral exceeded that of the ion. This versatile instrument was rebuilt several times and eventually accompanied the author when he moved to the University of Delaware in 1987.

Figure 13 is the schematic for the first triple quadrupole mass filter tandem mass spectrometer, a collaboration that involved Marvin and Visiting Professor James Morrison from Monash University in Australia. Our triple quad was a home-build system fabricated at no charge by the uncle of a talented graduate student, Steve Vredenburg, who chose veterinary medicine for his career rather than mass spectrometry. Steve remains a good friend who enjoys exchanging stories of our divergent careers. The triple quad went to the University of Houston with Marvin when he began his own academic career, and Morrison's improved version of the triple quad built at Monash launched a new field of ion reaction chemistry. (For a snapshot of Marvin's current interests see the paper by Vestal and Standing in this volume.)



Figure 10. Marvin Vestal overseeing the dissection of an Associated Electrical Industries MS-30 double beam mass spectrometer as the initial step for improving its analytical capabilities.

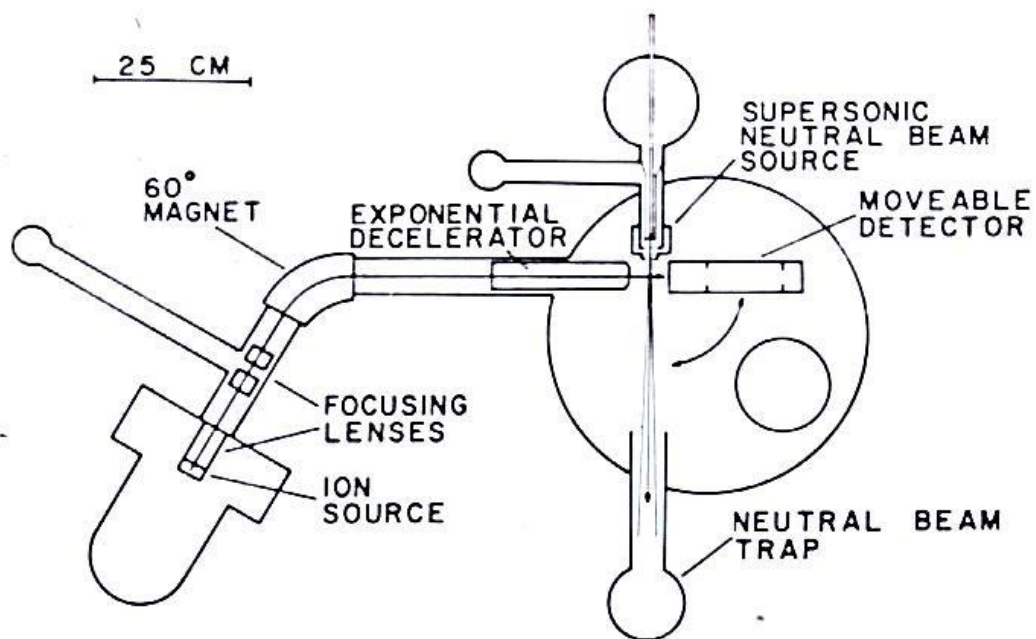

Figure 11. First Supersonic Jet Ion/Neutral Crossed Beam Apparatus that enabled investigations of dynamics of ion-neutral collisions at very low relative energies.

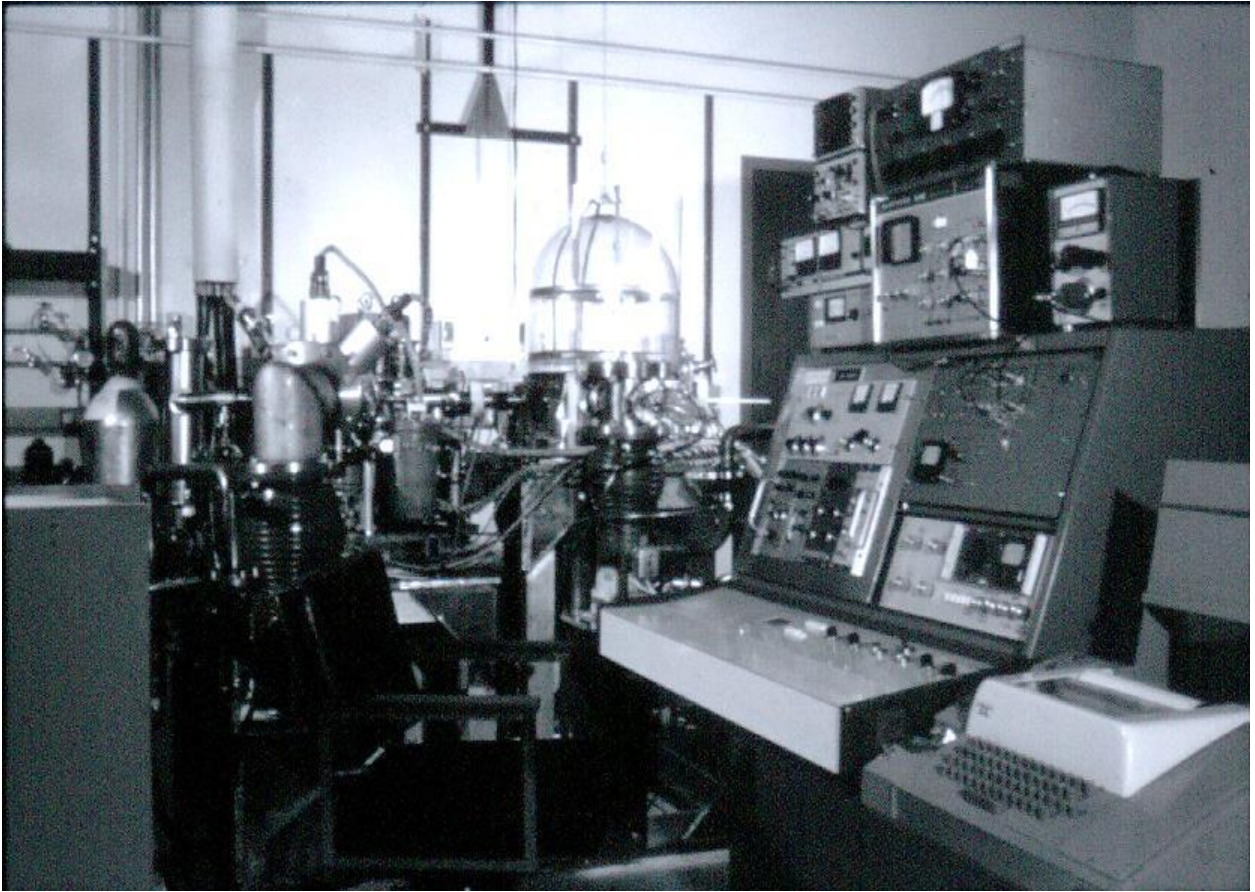

Figure 12. Photograph of Utah supersonic jet ion-neutral crossed beam apparatus as initially constructed.

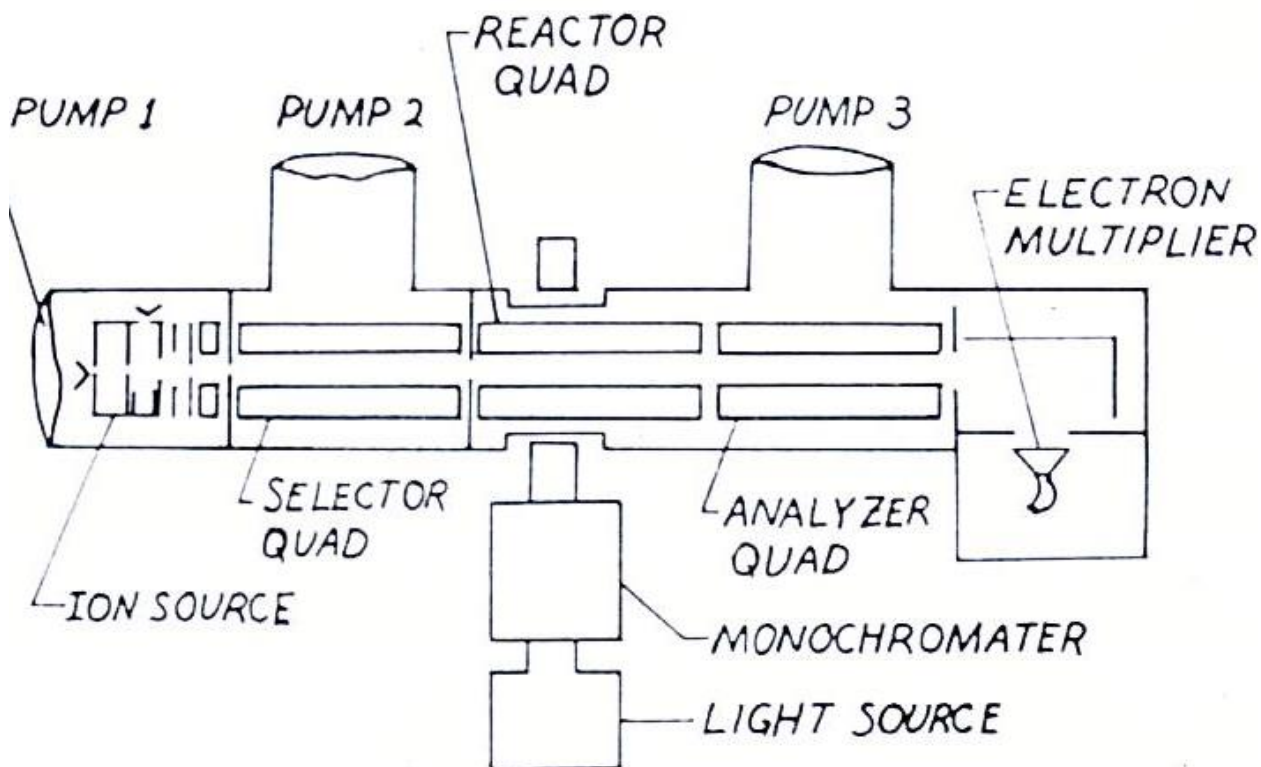

Figure 13. First triple quadrupole tandem mass spectrometer, utilized at Utah and University of Houston for ion photodissociation studies. An improved version was later deployed by Jim Morrison and his students at the University of Melbourne.

As noted, the original crossed-beam apparatus shown in Figures 11 and 12 was rebuilt and improved several times and eventually crossed the United States with me when I moved to the University of Delaware in 1986. It was the basic instrument we used to investigate the dynamics, as distinguished from kinetics and mechanisms, of ion-molecule reactions. More details of such studies and their history is given in the chapter in this volume co-authored by my long-term friend and collaborator, Zdenek Herman. Figure 14 is a snapshot symbolizing my many years of collaboration with Zdenek; it depicts younger versions of Zdenek, his graduate student Bretislav Friedrich and the author in front of a similarly modified and improved crossed beam apparatus that we used in Prague for the first demonstration of the dynamics of ion-neutral collisions at higher kinetic energy. This experiment illustrated the influence of the repulsive part of the potential on dynamics of moderate energy collisions; this is the basic excitation mechanism for collision-induced-dissociation processes. (For more information on crossed-

beam dynamics please see Zdenek Herman and Jean Futrell's retrospective article in this Special Issue.)

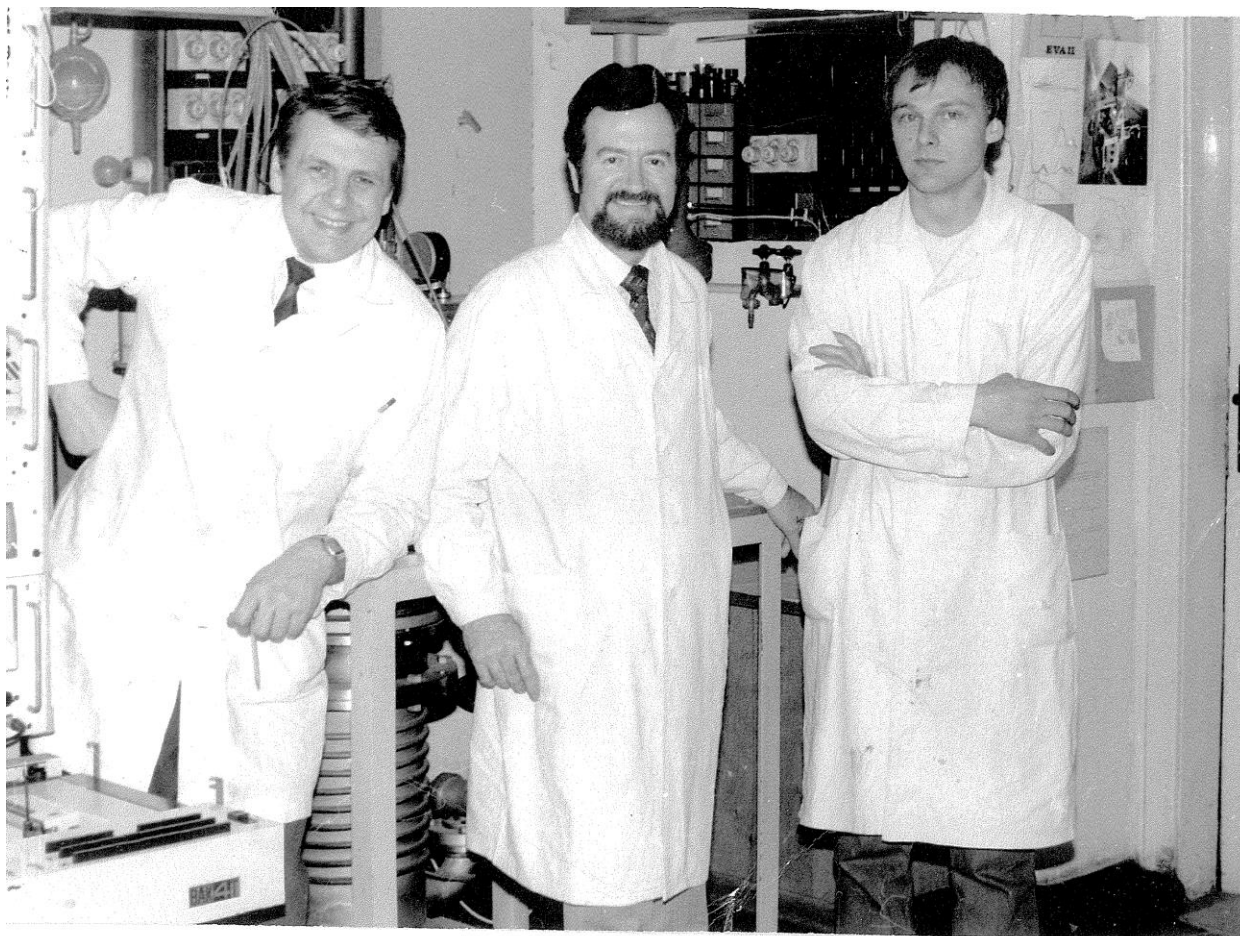

Figure 14. Fulbright Exchange Fellow Jean Futrell with his host, Dr. Zdenek Herman of the J. Heyrovsky Institute in Prague and graduate student Bretislav Friedrich. Here we celebrated the first crossed-beam experiment demonstrating the dynamics of collision-induced dissociation reactions.

As a post-doc in my Utah laboratory Bretislav—now at the Max Planck Institute in Goettingen—was responsible for reconstructing and making major improvements in the Utah crossed-beam apparatus. When it moved across the country to become the Delaware crossed-beam apparatus it was again improved and utilized for seminal experiments on the dynamics of collision-induced dissociation. This is the fundamental mechanism for applied tandem mass spectrometry—mass selection in a first stage instrument, collisional activation and analysis of

products—to probe the structure of mainly higher mass molecules. These topics are discussed in several papers in this Special Issue.

The closing chapter of my personal participation in this great adventure of mass spectrometry, surface-induced dissociation (SID), was a natural outgrowth of our work on collision-induced dissociation, begun at the University of Delaware and continued when I moved to the Pacific Northwest National Laboratory in 1999. Figure 15 is a cartoon summarizing the collisional activation when the neutral partner is a surface at rest rather than a recoiling molecule. This depicts a self-assembled monolayer on a gold crystal. These special surfaces comprise a nearly defect-free surface that is a semi-conductor to minimize surface charging and orients a particular group on the surface of the carbon chain with a defined angle. For alkyl chains (and alkyl fluorocarbons) even carbon chains orient the terminal group orthogonal to the surface. Accordingly we may consider, for moderate ion kinetic energy (tens to hundreds of electron volts) we may think of these surfaces as pincers that hold the neutral molecule collider in place for optimum conversion of ion kinetic energy into internal and recoil kinetic energy.

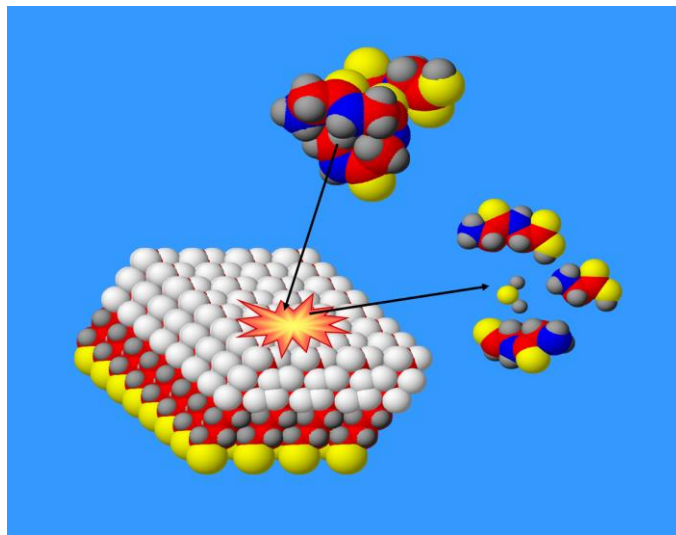

Figure 15. Cartoon depiction of surface-induced-dissociation of a complex molecule on a self-assembled monolayer bonded to a Gold-111 crystal surface.

Figure 16 is a schematic for what I thought was the final tandem mass spectrometer of my career. (Fortunately this turned out to be overly pessimistic.) An ion source and ion funnel designed at PNNL injects ions into a triple quadrupole mass spectrometer that performs the usual tricks of mass selection, collisional relaxation to define a thermal distribution of internal energies and transfers it through various optical turns and twists and inserts it into an FTICR for carrying out ion-surface collisions. Figure 17 is a photograph of the spectrometer with one of

the principal designers, then Post-doctoral Fellow Eduard Denisov, (additional key players not shown included PNNL staff scientists Anil Shukla, Steve Barlow and Julia Laskin). Eduard is now a Principal Scientist at Thermo-Scientific who has played a major role in developing the Orbitrap mass analyzer, a commercial version tandem mass spectrometer described in Alexander Makarov's paper in this Special Issue. Our initial interest was ion dissociation and we enjoyed demonstrating that almost all the principles developed earlier to understand and predict the outcome of gas phase ion collisions also apply to this entry into interfacial science. Variations on this instrument, including the addition of additional stages to interrogate what is happening on the surface following ion capture (and derivative designs for ion deposition and in-situ characterization) are described in the section on ion-surface collisions in this Special Issue.

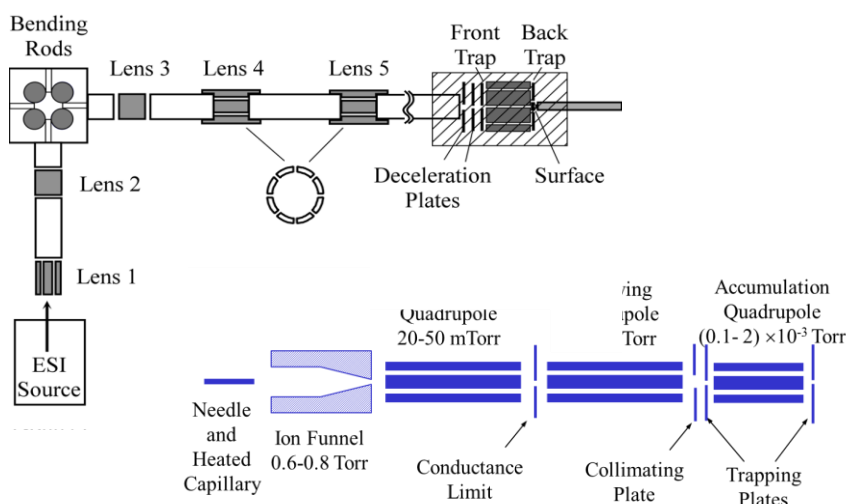

Figure 16. Schematic of tandem FTICR spectrometer for SID activation of peptide ions

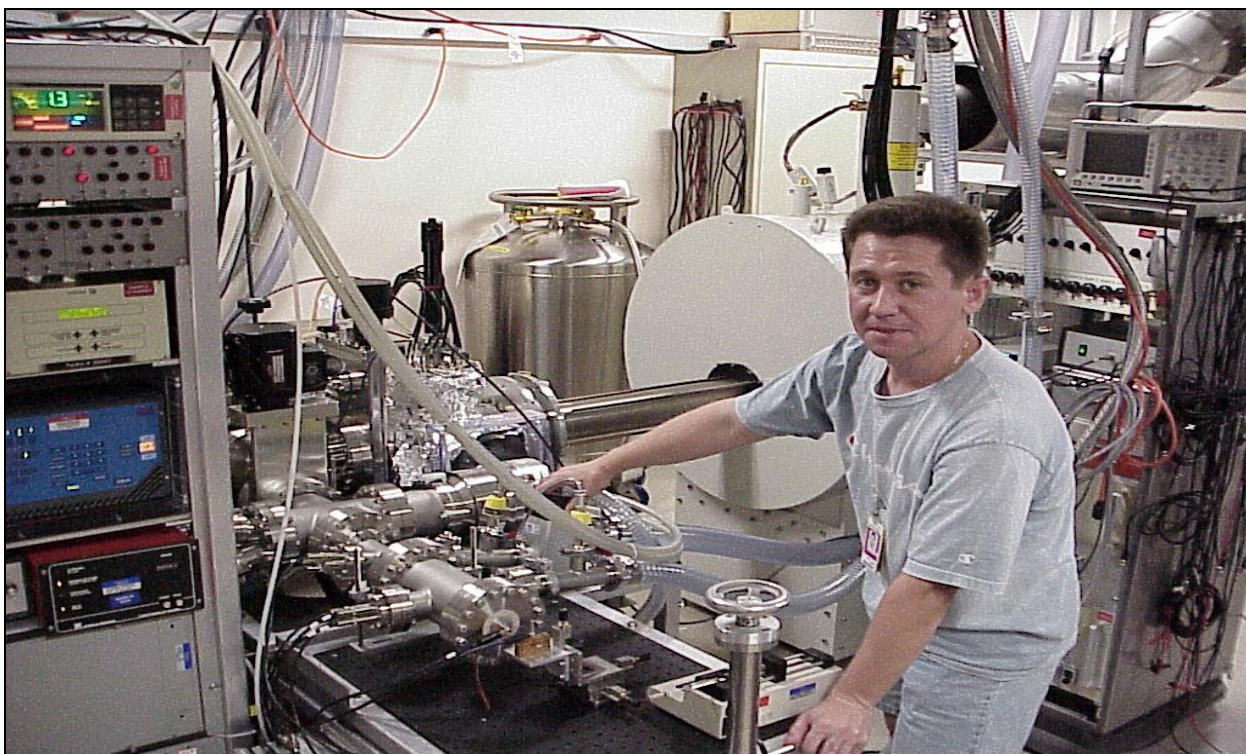

Figure 17. Postdoctoral Fellow Eduard Denisov commissioning the PNNL Tandem SID FTICR spectrometer in 2002

In conclusion, the period from 1960's to the present has been an enormously exciting adventure for mass spectrometry and it has been a distinct honor for the author to participate in this "revolution in instrumental science" and to organize, with many colleagues and friends, what we hope will be an interesting trail of discovery that describes in broad strokes the foundation studies and bright future of mass spectrometry as an indispensable tool for exploring the molecular sciences frontier.

INDEX

2

21-110. *See* mass spectrometer:Consolidated
Electrodynamics Corporation (CEC) 21-110

A

Acrivios, Andrew, 28
Aerospace Research Laboratory, 62, 82
Agent Orange, 96
Air Force Materials Laboratory, 71, 82
Alexandria, Louisiana, 15
American Chemical Society, 22, 29, 109
American Institute of Chemical Engineers, 22, 23,
109
American Recovery and Reinvestment Act of 2009,
126, 127
American Society for Mass Spectrometry, 92, 94,
107
American Society for Testing and Materials, 35
Ames Laboratory, 35
Argonne National Laboratory, 31, 115, 121
ARL. *See* U.S. Air Force:Aerospace Research
Laboratory
ASMS. *See* American Society for Mass
Spectrometry
Associated Electrical Industries. *See* mass
spectrometer:Associated Electrical Industries
ASTM. *See* American Society for Testing and
Materials
Atlanta, Georgia, 65

B

Baldeschwieler, John D., 27, 31, 97
Baltimore, Maryland, 76
Basic Energy Sciences. *See* U.S. Department of
Energy:Office of Science:Basic Energy Sciences
Baton Rouge, Louisiana, 10
Battelle, 108, 115, 120, 122, 123
Battelle Fellow, 122, 123, 124, 127, 142
Battle of Pearl Harbor, 6
Baytown Research Center, 22, 52, 64, 65
Baytown, Texas, 22, 47, 51, 52, 53, 54, 57, 63
Beauchamp, Jesse L., 128
Bell & Howell Company, 70, 88
Bell Laboratories, 50
Bendix Corporation, 84
Biggerstaff, Julie, 140
Biloxi, Mississippi, 65
Blakley, Calvin R., 95

Boston, Massachusetts, 23, 41
Brookhaven National Laboratory, 31, 121, 122
Brussels, Belgium, 91

C

C&E News. See Chemical & Engineering News
California, 3, 6, 9, 11, 13, 26, 43, 45, 47, 81, 84
California Institute of Technology, 25, 27, 85, 128
Caltech. *See* California Institute of Technology
Calvin, Melvin, 3
CCC. *See* Civilian Conservation Corps
CEC. *See* Consolidated Electrodynamics Corporation
Chemical & Engineering News, 56, 116
Chemical Heritage Foundation, 67
Chicago, Illinois, 23, 24
China, 102, 122
Chu, Secretary Steven, 125
Civilian Conservation Corps, 2, 14
collaboration, 108, 126, 127, 133
collision-induced. *See* mass spectrometry:collision-
induced dissociation
Columbia University, 35
competition, 11, 143
Consolidated Electrodynamics Corporation, 36, 65,
66, 67, 70, 71, 72, 79, 88
Cooks, R. Graham, 130, 131, 132, 133, 135
Cornell University, 60, 103
Coulomb's Law, 58
Council for Chemical Research, 108, 109, 121
Cunningham, Burris B., 30

D

Debye, Peter J.W., 57, 58, 59, 60, 132
Delaware General Assembly, 106
dichloroethylene, 39
DOE. *See* U.S. Department of Energy
double focusing. *See* mass spectrometer:double
focusing
Douthett, Elwood M., 47, 61
Dow Chemical Company, 97
Dry Prong Elementary School, 4
Dry Prong High School, 10
Dry Prong, Louisiana, 4, 10, 11, 19, 33, 41, 50, 54,
80, 138
Dubois, Jean-Marie, 62, 63, 81, 82
DuPont [Chemical] Company, 23, 49, 104, 107

E

Eastman Kodak Company, 31

Edwards Air Force Base, 43
Emeryville, California, 47, 48
England, 63, 70, 77, 78, 122
EPA. *See* U.S. Environmental Protection Agency
Exxon Corporation, 22, 53, 54, 57, 64, 65
Eyring, Henry, 11, 24, 49, 83, 84, 102, 134, 144

F

Faraday, Michael, 58
 Faraday cups, 58
Fenn, John B., 95, 131, 132
Fermi, Enrico, 58, 112
Field and Franklin Award, 133
Field, Frank H., 48, 51, 52, 54, 64, 65
Finnigan, Robert E., 91
Fletcher, James C., 85
France, 122, 140
Franklin, Joe L., 22, 48, 51, 52, 61, 64, 65, 84
FTICR. *See* mass spectrometry:Fourier transform ion
 cyclotron resonance
Futrell, Ellen Catherine Padgett (mother), 16
Futrell, Homer Elmore (father), 16

G

gas chromatography, 37, 39, 53, 84, 93
gas phase ion, 48, 63, 64, 65, 135
Germany, 82, 122
Ghiorso, Albert, 56
Giauque, William F., 30
Giddings, J. Calvin, 84, 93
Graham, Anne Krohn (wife), 12, 33, 106, 107, 117,
 118, 119, 125
Grant Parish, Louisiana, 1, 4, 14, 17, 19
Grant, President Ulysses S., 1
grants/funding, 32, 50, 70, 83, 92, 94, 95, 98, 99,
 107, 109, 113, 114, 115, 116, 121, 122, 123, 125,
 126, 127, 132, 143, 147
Great Britain, 37
Great Depression, 2, 3
Guggenheim Fellowship, 40
Gulf of Mexico, 51
Guynes, Vera, 14

H

Hanford, Washington, 111, 112
Harvard University, 24, 27, 60, 96
Hase, William J., 133, 135
Hildebrand, Joel H., 29
Houston, Texas, 57, 60, 95
Humble Oil and Refining Company, 22, 52, 60, 105
 Humble Chemical Physics Mass Spectrometer, 54

I

Idaho National Laboratory, 122
Illinois, 17
International Mass Spectrometry Conference, 91,
 132
ion cyclotron resonance. *See* mass spectrometer:ion
 cyclotron resonance
ion molecule chemistry, 47, 48, 52, 54, 63, 64, 71,
 79, 80, 89
Italy, 122

J

Japan, 6, 122
Jennings, Keith R., 63, 77, 78, 87
Johnson, Claudia Alta Taylor [Lady Bird], 52
Johnson, President Lyndon Baines, 52
Johnston Laboratories, Incorporated, 76, 88
Johnston, William H., 76
Joint Institute for Laboratory Astrophysics, 92

K

Kennedy, President John F., 125
Kisatchie National Forest, 3, 14
Korea, 122
Korean Conflict, 19
Kuyatt, Chris E., 76

L

Lackland Air Force Base, 21, 23
Lammot duPont Laboratory, 107
Lampe, Frederick W., 48, 51, 52, 63, 64, 65
Laskin, Julia, 125, 133, 135
Lawrence Berkeley National Laboratory, 115, 121,
 145
Lawrence Livermore National Laboratory, 122, 125
Lawrence, Ernest O., 32, 37
Lifshitz, Chava, 133
Lind, Samuel C., 42
liquid chromatography. *See* mass spectrometer:liquid
 chromatography
Long, Governor Earl, 4
Long, Governor Huey P., Jr., 4, 5
Los Angeles, California, 23
Louisiana, 2, 3, 5, 12, 15, 19, 140
Louisiana State University, 10, 11
Louisiana Tech University, 12, 19, 20, 21, 24, 33
LSU. *See* Louisiana State University
Lumpkin, Henry Earl, 64

M

Mallory, Eugene, 81
Manhattan Project, 31

Marshall, Alan G., 116, 126, 127
 Mason-Dixon Line, 27, 28
 mass spectrometer, 22, 31, 33, 36, 48, 51, 54, 58, 65, 66, 67, 70, 71, 72, 73, 74, 75, 79, 83, 84, 86, 88, 89, 90, 91, 92, 101, 102, 113, 127, 129, 130, 135, 145, 146
 Associated Electrical Industries, 70
 chemical ionization, 84, 88, 89, 90, 91, 106
 Consolidated Electrodynamics Corporation (CEC) 21-102, 36
 Consolidated Electrodynamics Corporation (CEC) 21-103C, 65, 66
 Consolidated Electrodynamics Corporation (CEC) 21-110, 70, 88
 Consolidated Electrodynamics Corporation 21-110, 86
 double focusing, 70, 71, 75, 77, 78, 101
 Fourier transform ion cyclotron resonance, 116
 ion cyclotron resonance, 85, 128
 liquid chromatography, 94
 MAT CH7, 90
 Mattauch-Herzog, 71, 72, 76, 77, 86, 88, 130
 Metropolitan-Vickers, 70
 Nier-Johnson, 72, 130
 quadrupole, 91, 92, 93, 94
 mass spectrometry, 31, 35, 37, 49, 52, 54, 55, 63, 65, 71, 74, 77, 83, 90, 94, 95, 98, 99, 100, 101, 102, 105, 113, 114, 116, 130, 145, 147
 absolute rate theory, 49, 63, 75, 76, 83, 87, 133, 134
 collision-induced dissociation, 86, 87, 101, 133, 134
 electron impact, 76, 88, 91, 102
 electrospray, 95, 102, 129, 135
 Fourier transform ion cyclotron resonance, 116, 126, 127
 gas chromatography, 37, 99, 100
 pyrolysis, 99
 thermospray, 94, 95
 time-of-flight, 70, 84, 86, 129, 130
 Massachusetts Institute of Technology, 23, 24, 27, 96
 Matheson Gas [Products] Company, 67
 Mattauch-Herzog. *See* mass spectrometer:Mattauch-Herzog
 McCloskey, James A., 93, 94, 95
 McLafferty, Fred W., 87, 95, 114, 116
 McMillan, Edwin, 30
 mentor, 130, 142
 Metropolitan-Vickers. *See* mass spectrometer:Metropolitan-Vickers
 Michnowicz, John, 106
 Miller, Dean, 79
 Millikan Oil Drop, 143
 Mississippi, 111

MIT. *See* Massachusetts Institute of Technology
 Moore's Law, 148
 Munson, M.S. Burnaby, 105

N

NASA. *See* National Aeronautics and Space Administration
 National Academy of Sciences, 49, 57, 82, 85, 109, 126
 National Aeronautics and Space Administration, 46, 52, 99
 National Bureau of Standards, 76, 77
 National Institute of Standards and Technology, 76, 93, 97, 99
 National Institutes of Health, 93, 94, 96
 National Science Foundation, 26, 27, 33, 40, 92, 98, 99, 126, 127, 143
 Nevada, 45
 New Orleans, Louisiana, 65
 New York City, New York, 50
 Newton, Amos, 31, 32, 35, 38, 55
 Nier, Alfred O.C., 130
 Nier-Johnson. *See* mass spectrometer:Nier-Johnson
 NIH. *See* National Institutes of Health
 NIST. *See* National Institute of Standards and Technology
 Nixon, President Richard M., 97
 NMR. *See* nuclear magnetic resonance
 Nobel Prize, 3, 29, 30, 39, 50, 82, 145
 Nobel, Alfred, 107
 NSF. *See* National Science Foundation
 nuclear magnetic resonance, 22

O

Oak Ridge National Laboratory, 41, 42, 43, 115, 121, 122
 Oakland, California, 41
 Obama, President Barack H., 125
 Office of Science. *See* U.S. Department of Energy:Office of Science
 Ohio, 61, 65, 82, 133
 Ohio State University, 133
 Otvos, J.W., 47

P

Pacific Northwest National Laboratory, 108, 111, 114, 115, 120, 121, 122, 123, 124, 125, 126, 127, 136, 138, 142
 Environmental Molecular Sciences Laboratory, 108, 111, 113, 115, 116, 120, 123
 Padgett, James Alfred (maternal grandfather), 16
 patent, 22, 37, 106, 108
 Pauling, Linus C., 23, 25, 145, 146

Peenemünde Army Research Center, 82
Pennsylvania State University, 65
Philadelphia, Pennsylvania, 57
Pimentel Report, 110, 113, 116
Pimentel, George, 110, 111
PittCon. *See* Pittsburgh Conference on Analytical
Chemistry and Applied Spectroscopy, Inc.
Pittsburgh Conference on Analytical Chemistry and
Applied Spectroscopy, 82
Pittsburgh, Pennsylvania, 33, 81
Pitzer, Kenneth S., 24, 26, 27, 28, 105
PNNL. *See* Pacific Northwest National Laboratory
Porter, George, 63
Princeton University, 49, 60
publish/publication, 29, 35, 47, 49, 63, 64, 67, 76,
78, 80, 89, 90, 93, 98, 126, 128, 135, 146
Purdue University, 76

R

Radiation Laboratory of the University of California,
30, 31, 35, 37, 39, 56
Reagan, President Ronald W., 6, 84
religion, 5, 84, 85
Rice University, 65
Rice-Ramsperger-Kassel-Marcus, 87, 128, 133, 134
Richland, Washington, 1, 122
Ridge, Douglas P., 105
Robert A. Welch Chair, 133
Robinson, Charles F., 71
Rockefeller University, 65
Roosevelt, President Franklin D., 2, 3
Rosenstock, Henry M., 49, 76, 77, 108
ROTC. *See* U.S. Air Force Reserve Officers'
Training Corps
RRKM. *See* Rice-Ramsperger-Kassel-Marcus theory
Ruston, Louisiana, 12

S

Sacramento, California, 47, 51, 52, 61
Salt Lake City, Utah, 79, 89, 94
San Francisco, California, 2, 6, 7, 23, 46
Schissler, D.O., 47
Schoomer, Bertrand Alva, 22, 25, 26
Seaborg, Glenn T., 29, 30, 31, 33, 34, 35, 36, 37, 38,
47, 50, 55, 56, 112, 125
Seattle, Washington, 114
Shell Laboratories, 47, 48
Shell Development Laboratory, 47
Shreveport, Louisiana, 19
Shukla, Anil K., 101, 102, 103, 131, 132
Simpson, John A., 76
Smith, Richard D., 108, 114, 116, 123, 129
Spanish-American War, 16

Sputnik, 45, 46, 142
Standard Oil Company of New Jersey, 53
Stanford Research Institute, 91
Stanford University, 24
Stevenson, D.P., 47
Switzerland, 122

T

Talrose, Victor L., 47, 78
Technology Vision 2020
The U.S. Chemical Industry, 109
Teller, Edward, 54
Templeton, David H., 55
tenure, 86, 104, 118, 143
Texas Tech University, 133
Thomas H. Harris Scholarship, 12
Tiernan, Thomas O., 97
Tureček, František, 87

U

U.S. Air Force, 20, 21, 43, 44, 46, 61, 62, 66, 68, 70,
79, 81, 82
Aerospace Research Laboratory, 66, 70, 74, 82
Strategic Air Command, 69, 82
U.S. Air Force Reserve, 41, 69
U.S. Air Force Reserve Officers' Training Corps, 20,
21, 23, 40, 51
U.S. Army Research Laboratory, 84
U.S. Atomic Energy Commission, 32, 125
U.S. Civil War, 1, 18
U.S. Congress, 127
U.S. Department of Defense, 122
U.S. Department of Energy, 113, 115, 120, 121, 122,
123, 124, 125, 126, 127
Office of Science, 97, 111, 115, 121, 122, 126
Basic Energy Sciences, 120, 121
Secretary, 118, 119, 125
U.S. Environmental Protection Agency, 96, 97, 98
U.S. Merchant Marines, 2
U.S. Navy, 2, 94
U.S. Office of Science
National User Facility, 115, 116
U.S. Senate, 96, 98
Union of Soviet Socialist Republics, 47, 142
United Kingdom, 87
United States Military Academy, 68
United States of America, 6, 19, 37, 41, 59, 64, 70,
76, 83, 109, 113, 141, 143
University of Arizona, 132
University of California, 83
University of California, Berkeley, 3, 11, 22, 24, 25,
26, 27, 29, 30, 31, 34, 35, 40, 41, 46, 50, 51, 53,
54, 82, 85, 86, 105, 118, 139, 145

University of California, Irvine, 83
University of California, San Diego, 118
University of Chicago, 11, 56
University of Delaware, 8, 23, 33, 102, 103, 104,
105, 106, 107, 109, 110, 111, 113, 114, 116, 117,
119, 121, 122, 130, 131, 132, 135, 140, 141
University of Houston, 94, 95
University of Utah, 28, 33, 49, 63, 83, 85, 86, 89, 93,
99, 101, 102, 134, 139, 141, 144
Flammability Research Center, 99
Henry Eyring Presidential Chair in Chemistry,
102
University of Utah Research Park, 99, 101
University of Washington, 87

V

Vestal, Marvin L., 75, 76, 88, 89, 90, 93, 94, 95, 101,
129, 130, 133
Vietnam [War], 98
Virginia Commonwealth University, 131
von Braun, Wernher, 46
von Kármán, Theodore, 61
von Ohain, Hans J.P., 82
Vredenburg, Steve, 92

W

Wahrhaftig, Austin L., 49, 63, 83, 84, 88, 93
Walla Walla, Washington, 118
Wallenstein, Merrill B., 49, 77
Walling, Cheves T., 35
Warwick Mass Spectrometry 80/60 Conference, 77
Washington State University, 111
Washington, D.C., 21, 56, 82, 98, 120, 125, 130, 143
Wiley, William R., 111, 113, 115, 116, 124
Williana, Louisiana, 1
Wilmington, Delaware, 23
World War I, 2
World War II, 2, 31, 35, 56, 145
Wright State University, 97
Wright-Patterson Air Force Base, 61, 62, 64, 65, 66,
69, 70, 71, 79, 81, 82, 85, 86, 91, 97, 122
Aerospace Research Laboratory, 61, 82, 122
Wysocki, Vicki H., 130, 131, 132, 133

Y

Yale University, 60